

Examples of materials that can be cut with Sonofile Ultrasonic Cutter

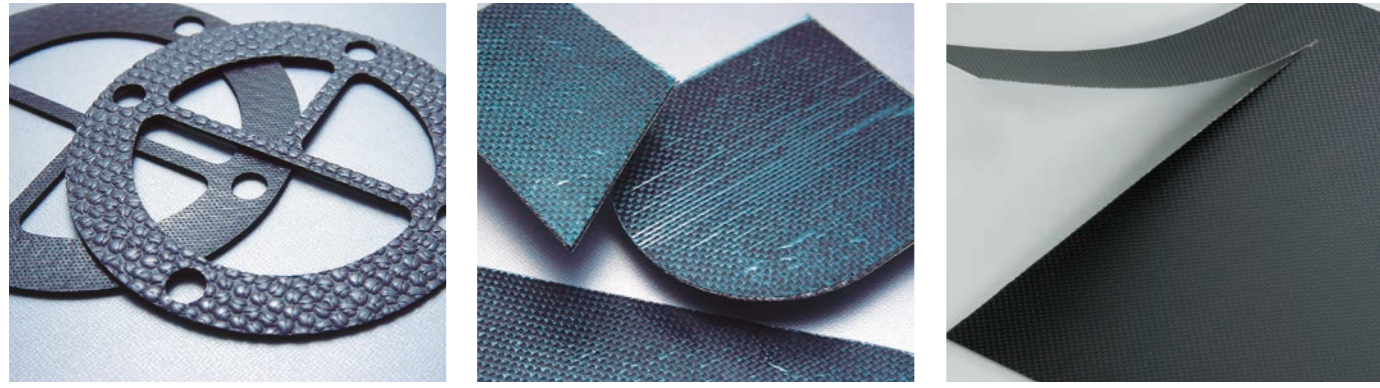

Carbon Prepreg



NR Sponge



Corrugated Elbow



Wide-mouth Bottle

Optional Tools



FB-0131-6L FB-3136-6L4 FB-3136-5H FB-3126-3L FB-3134 FB-4136-1W
FB-3186-4L FB-0231-6L FB-3294-2 FB-4221-9 FB-3296-1 FB-3236-6L FB-3234

Various Blades for Reference



Option / Torque screwdriver for blade mounting



SONOTEC Co., Ltd.

5-4-1 Shinsaku, Takatsu, Kawasaki, Kanagawa 213-0014 Japan
TEL:+81-44-877-8311 FAX:+81-44-877-8312
e-mail:info@sonotec.com

www.sonotec.com

2015.06.1000

ULTRASONIC CUTTER

SONOFILE®

SH-3510 / SF-3441 / SF-3400II / SF-653 / SF-0102 / SF-30



SONOFILE®

The ultrasonic cutter is a safe and clean processing machine that does not discharge cutting chips, polluted water, noise or smoke. The cutting blade performs expansion and contraction movements at an ultrafast speed of 20,000 times or over per second with the amplitude of up to 70 microns. As a result, it can cut the materials that are usually hard to cut easily and beautifully. The SONOFILE ultrasonic cutter, utilizing ultrasonic vibrations of a specialized processing machine manufacturer SONOTEC features excellent durability and smooth operability as well by employing our own blade holding system.

ULTRASONIC CUTTER SIRIES

SH-3510



CE



SF-3441



CE



SF-3400 II



SF-653



CE



SF-0102



CE

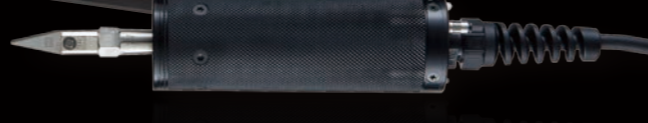

SF-30







We will test-cut free of charge if a work sample is provided.

We will choose the combination of the oscillator and the transducer, which are optimum for the intended material and the cutting conditions. With our knowledge and experience accumulated for a long period, we will propose the ultrasonic cutters that best fit the customer. Check the sharpness of our cutter through the test cutting.



We own a patent for the blade holding system.

Notations used in this leaflet :

-  Product conforming to CE
-  For use with automated equipment
-  For use with manual equipment
-  Mechanism that the cord and the air tube rotate
-  Detachable cord (For details, see Page 5.)

SONOFILE SH-3510

HP-8701/HP-8110/
SF-3110/SF-8500RR/etc.

High-power Ultrasonic Cutter featuring Maximum Output of 500 W

The oscillator with a maximum power output of 500 W enabled powerful cutting of difficult-to-cut and extra-tough work pieces. Abrasion resistant carbide blade with 1 mm thickness can be used. Exchanging signals for on/off, emergency stop, change of output level, and other features with automated machinery or industrial robots is, of course, possible.

Features

- ◎ Cutter with a maximum power output of 500 W capable of handling materials requiring high-power cutting.
- ◎ Tools including carbide blades and long blades can be used.
- ◎ Mountable on automated machinery, industrial robots and plotters.

SH-3510



- ◎ Cutter with a maximum power output of 500 W capable of handling materials requiring high-power cutting.
- ◎ Tools including carbide blades and long blades can be used.
- ◎ Mountable on automated machinery, industrial robots and plotters.

Specifications

Frequency adjustment	Automatic tracking type
Maximum output	500 W
Output adjustment	Step-less continuously-variable type
Power requirement	Single phase 200 VAC, 50/60 Hz
Power consumption	1000VA
Outer dimensions	300 (W) x 400 (D) x 200 (H) (mm)
Weight	10.2kg
Function	Detection of error cause
External device connection function	Oscillation ON/OFF, Adjustment of ultrasonic output, Warning of error stop, Recovery from error

SONOFILE SF-3441

SF-8541RR/SF-8500RR/SF-3110
etc.

Standard Model for Use with Automated Machinery

This ultrasonic oscillator is capable of exchanging signals with the main units of automated machinery, industrial robots, plotters, etc., for operations, such as turning on/off, emergency stop and switching the output level.

Features

- ◎ Powerful ultrasonic cutter with a maximum power output of 300 W.
- ◎ Mountable on automated machinery, industrial robots and plotters.

SF-3441

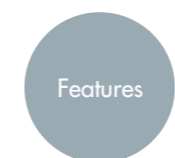

- ◎ Various types of prepregs (boron, Kevlar, polyethylene fibers, etc.)
- ◎ Rubber (vulcanized latex, non-vulcanized latex, sheeting materials, sealing materials and tubes) and leather (natural and artificial)
- ◎ Thermoplastics (boards, sheeting materials, films, laminated materials, flooring materials)
- ◎ Fabric materials, nonwoven fabrics and paper (specially-treated paper and coated paper)

Specifications

Frequency adjustment	Automatic tracking type
Maximum output	300 W
Output adjustment	Step-less continuously-variable type
Power requirement	Single phase 200 VAC, 50/60 Hz
Power consumption	500 VA
Outer dimensions	232 (W) x 340 (D) x 170 (H) (mm)
Weight	6.5 kg
External device connection function	Oscillation ON/OFF, Adjustment of ultrasonic output, Warning of error stop

for SH-3510



HP-8701

The transducer generates powerful and stable vibrations even for cutting that requires high power, and the profile is designed to endure long-term use.

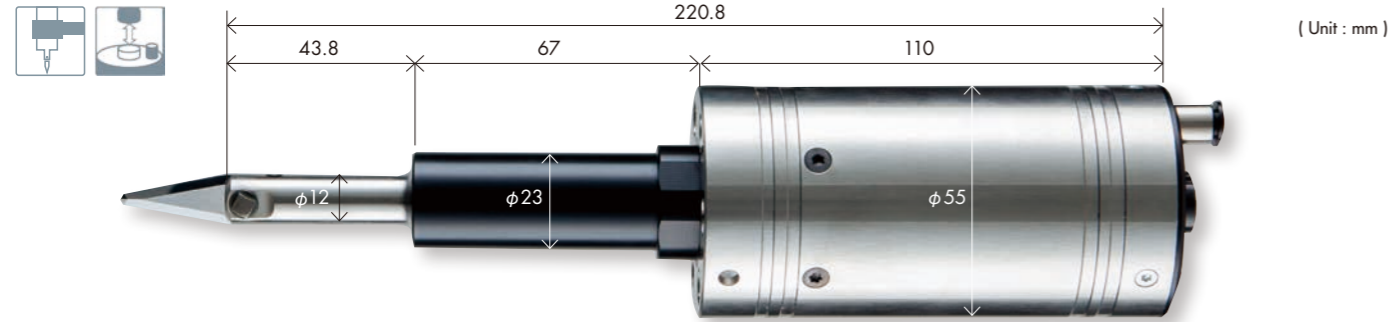

Standard Tools



Specifications

Frequency	24 kHz
Cord length	Up to 10 m
Housing material	SUS303 / Resin (Duracon)
Outer dimensions	φ12 / φ23 / φ55 x 221L (mm)
Weight	1,160 g
Blade thickness	1.0 mm

HP-8110

The transducer is suitable for gate cutting of molded articles containing glass or carbon fibers, which are hard to cut or machine in the past.

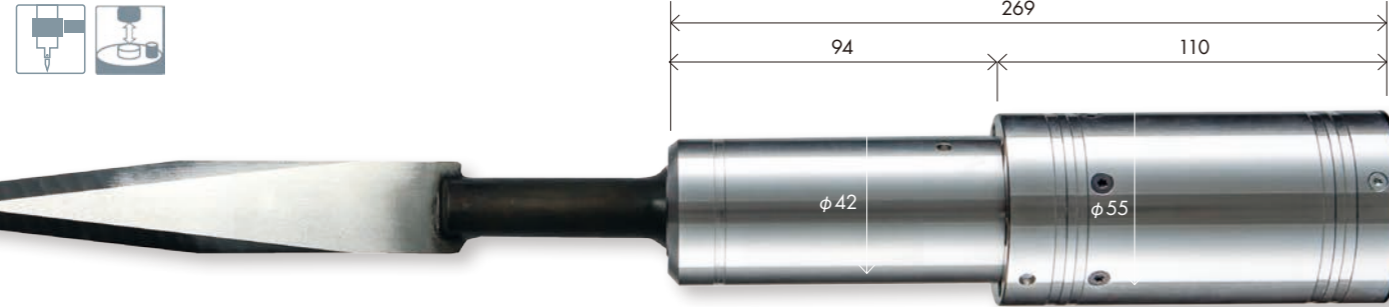

* The total length varies depending on the tool on which the transducer is mounted.

Optional Tool



Specifications

Frequency	20 kHz
Cord length	Up to 10 m
Housing material	SUS303
Outer dimensions	φ42 / φ55 x 269L (mm)
Weight	1,600 g (excluding the cord)
Blade thickness	The thickness depends on the specifications.

New method enabling easy detachment employed

The new method enabling easy detachment is employed. As a result, wiring of the cable becomes easier when mounting the transducer on robots, and the serviceability has been further enhanced. For the socket profile, choose either of the straight type or the angle type. The standard cord length is 5 m, which can be changed. (If the customer requires the conventional type, we will manufacture it on the custom-order basis.)

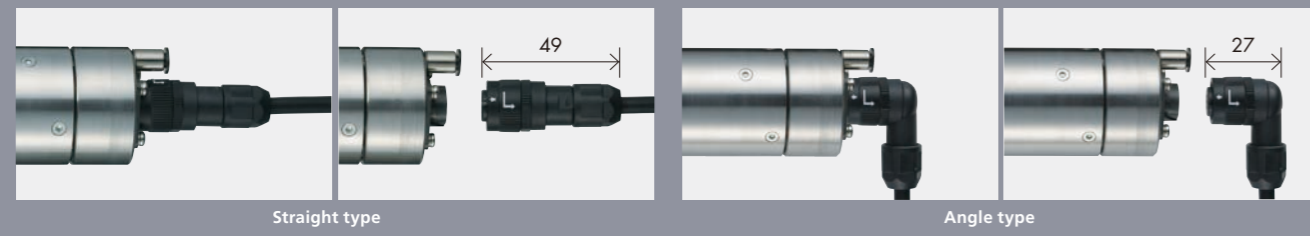

* The tools can be chosen out of our abundant product lineups according to the intended use. We also design and manufacture custom-order tools. Specifications are subject to change without prior notice for continual improvements. Please confirm when placing your order.

for SH-3510



SF-3441



SF-3110

The main body of the transducer is a cylindrical duralumin case that is easy for mounting on automated machinery. The blade width can be selected according to applications, which enables to design the blade that fits the profile of the article to be machined. Particularly, the transducer is best fit to up-and-down push cutting (guillotine system) and punching.

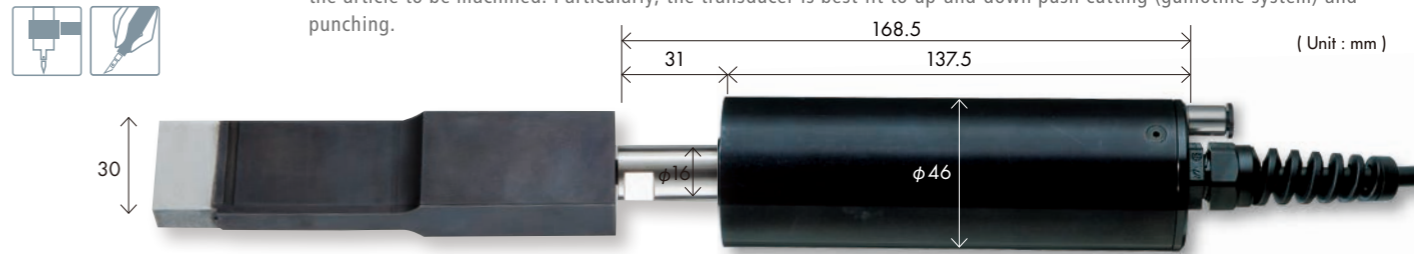

Punching Sample

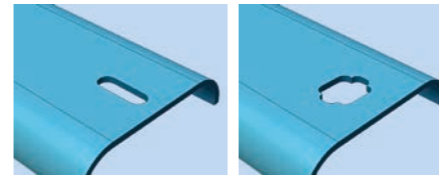

* We can make various types of custom-order punching tools.

Specifications

Frequency	20 kHz
Cord length	Up to 10 m
Housing material	Aluminum alloy
Outer dimensions	φ16 / φ46 x 168.5 L (mm)
Weight	600 g (excluding the cord)
Blade thickness	The thickness depends on the specifications.

SF-8500RR

This is a large amplitude type where the blade vibration amplitude is made larger than conventional models. With a 42 mm diameter cylindrical shape, the model is easy to be mounted on automated machinery, industrial robots and plotters. It is best suited for cutting and punching processing of 3D parts by mounting on industrial robots, in addition to processing of sheets and punching.

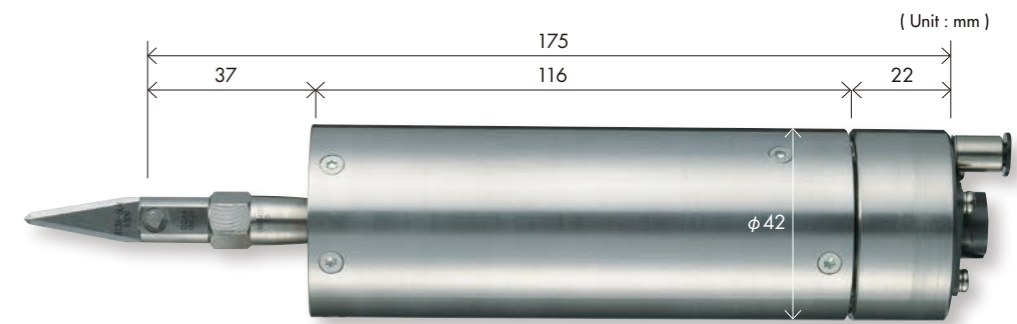

Standard Tools



Specifications

Frequency	22 kHz
Cord length	Up to 10 m
Housing material	SUS 303
Outer dimensions	Hexagonal 11 / φ42 x 175L (mm)
Weight	650 g
Blade thickness	The thickness depends on the specifications of holder (0.4 to 1.0 mm)

SF-8541RR

The transducer features compact size, but powerful performance thanks to the high frequency drive, thereby ensuring sharp cutting. The user-friendly design of shape enables to fully utilize the robot's operation area. A forced air-cooling system and extended continuous use have been realized by featuring the air inlet.

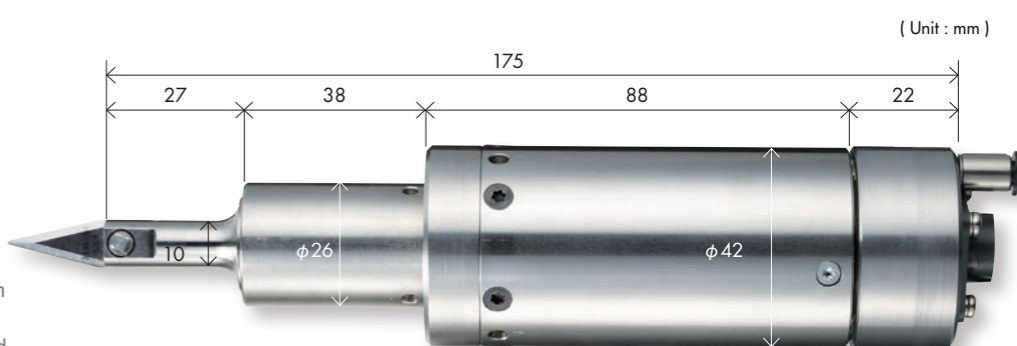

Standard Tools



Specifications

Frequency	40 kHz
Cord length	Up to 10 m
Housing material	SUS 303
Outer dimensions	φ10 / φ26 / φ42 x 175 L (mm)
Weight	650 g
Blade thickness	0.6 mm

SONOFILE SF-653

HP-653

Our unique power circuit and the use of cooling air have enabled the continuous long-hour use.

This is a high-frequency cutter featuring the 40 kHz (40,000 vibrations per second) vibration frequency of tool with the amplitude of 30 microns. It maximizes the effect of ultrasonic high-speed micro vibrations. A wide range of materials, including newly developed composite materials, rubber and leather, can be cut at will with low processing pressure, sharp cutting surface and little cutting chips. The power control circuit specially developed by us and the cooling air inlet suppress the heat generation of transducer even for large amplitude, thus enabling extended continuous use. (For a long-time operation without air cooling, contact us.)

Features

- Stable vibrations with a maximum amplitude of 30 microns ensure remarkable cutting performance.
- Our unique technologies suppress the heat generation of transducers, thus enabling extended continuous use.
- Adoption of the exclusive square-head screws and the screwdriver ensures easy and robust mounting of tools.

Applicable Materials

- Rubber (vulcanized latex, non-vulcanized latex, sheeting materials, sealing materials and tubes) and leather (natural and artificial)
- Thermoplastics (boards, sheeting materials, films, laminated materials, flooring materials)
- Fabric materials, nonwoven fabrics, and paper (specially-treated paper and coated paper)

Specifications: Oscillator

Frequency adjustment	Automatic tracking type
Maximum output / Output adjustment	100 W / Step-less continuously-variable type
Power requirement	Single phase 200 VAC, 50/60 Hz
Power consumption	300 VA
Outer dimensions	230 (W) x 232 (D) x 144 (H) (mm)
Weight	4.6 kg
External device connection function	Oscillation ON/OFF, Detection of high load, Warning of error stop, Recovery from error

Oscillator SF-653



Transducer HP-653

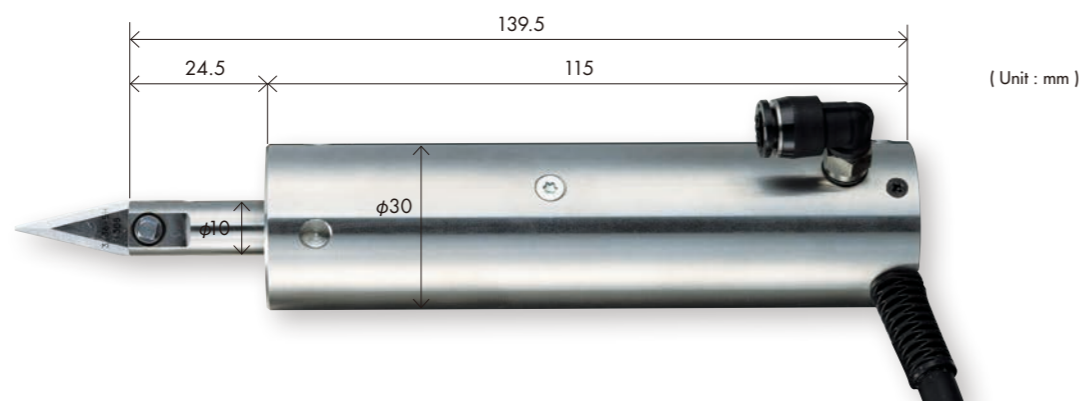

Specifications: Oscillator

Frequency	40KHz
Cord length	Up to 10 m
Housing material	SUS 303
Outer dimensions	φ10/φ30×139.5L (mm)
Weight	300 g (excluding the cord)
Blade thickness	The thickness depends on the specifications of the holder. (0.4 mm / 0.5 mm / 0.6 mm)

Standard Tool



FB-3136-5H

SONOFILE SF-0102

HP-2200

CE-compliant, versatile manual-type ultrasonic cutter

This is a manual type ultrasonic cutter, which daringly pursued nice user-friendliness. It is provided with a portable handle and storage rack for use at various jobsites. It is best fitted for a wide range of applications including carbon prepregs, resins, rubber, and fabrics. For safety measures, the activation of ultrasonic vibration is reported with illumination and sound. The product complies with the CE Standard.

Features

- An ultrasonic cutter featuring the size convenient for carrying around.
- The transducer is provided with a hand switch and the activation of operation is notified with illumination and sound
- The cutter can also be used as a versatile machine for cutting various materials.

SF-0102 comes with the dedicated storage rack.

Applicable Materials

- Carbon prepregs with thickness up to t10
- Thermoplastics
- Rubber
- Fabrics

Specifications: Oscillator

Frequency adjustment	Automatic tracking type
Maximum output / Output adjustment	100 W / Step-less continuously-variable type
Power requirement	Single phase 200 VAC, 50/60 Hz
Power consumption	300 VA
Outer dimensions	230 (W) x 232 (D) x 144 (H) (mm) (194 (H) including the handle)
Weight	4.8 kg (5.7 kg including the storage rack)
External device connection function	Oscillation from transducer ON/OFF While oscillation is activated, the lamp on the transducer illuminates and sound is generated from the oscillator.

* Manufacturing of the 200 V type is also possible.

Oscillator SF-0102



Transducer HP-2200

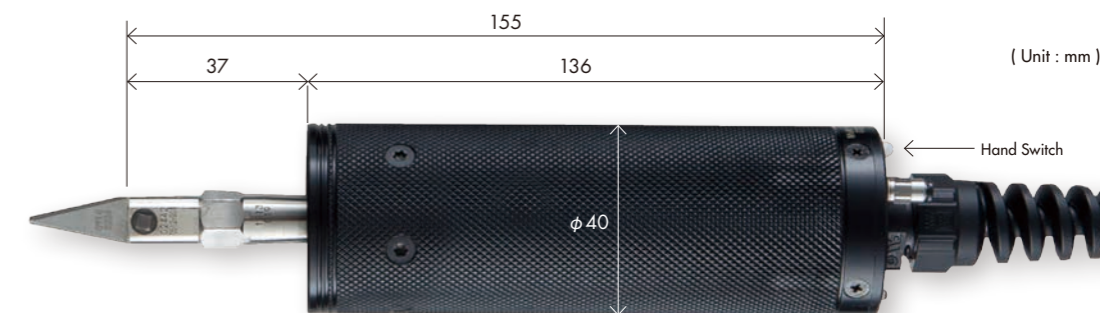

Specifications: Oscillator

Frequency	22 kHz
Cord length	3 m
Housing material	Resin (Duracon)
Outer dimensions	Hexagonal 11 / φ40 x 155L (mm)
Weight	350 g
Blade thickness	0.4 mm

Standard Tools



FB-3234



FB-3294-2

* The tools can be chosen out of our abundant product lineups according to the intended use. We also design and manufacture custom-order tools. Specifications are subject to change without prior notice for continual improvements. Please confirm when placing your order.

SONOFILE SF-3400II

SF-7400 / SF-3140

High-output cutter for manual operation: Assisting manual operations with clear cutting

This is a high-power ultrasonic cutter featuring the ultrasonic power output of 220 W. The tool's ultrasonic vibrations at a frequency of 22 kHz (22,000 vibrations per second) drastically reduce the cutting resistance. Varieties of materials can be cut even more rapidly and cleanly with a lower processing pressure. A function to enable constant monitoring of loads during cutting was added anew, thereby ensuring added safety and user friendliness.

Features

- The output adjustment can be done in step-less and continuous manner from the minimum to the maximum levels.
- The constant amplitude circuit always keeps vibrations at stable amplitude.
- The overload protection circuit is featured.
- Force air cooling is possible by installing the air inlet (SF-3140).

Applicable Materials

- Plastics (boards, sheets, films, laminated materials)
- Various types of prepregs (single sheet cutting, overlapped cutting)
- Leather (natural and artificial)
- Rubber (vulcanized latex, non-vulcanized latex)
- Fabric materials, nonwoven fabrics
- Paper and cardboards

Specifications: Oscillator

Frequency adjustment	Automatic tracking type
Maximum output	220 W
Output adjustment	Step-less continuously-variable type
Power requirement	Single phase 100 VAC, 50/60 Hz
Power consumption	500 VA
Outer dimensions	142 (W) x 294 (D) x 210 (H) (mm) (260 (H) including the handle)
Weight	4.5kg



Oscillator SF-3400II

Transducer SF-7400



This is a manual-operation type transducer that allows the use of large tools, such as of the chisel type and knife type to assist high power manual operations, including stripping exterior building walls and rust removal.

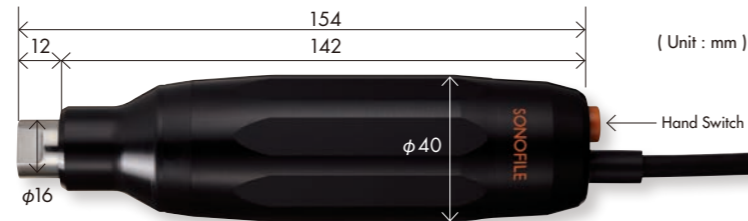

Optional Tool

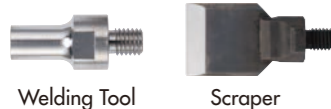

SF-3140



This is a highly versatile hand tool compatible with small and large blades depending on the applications.

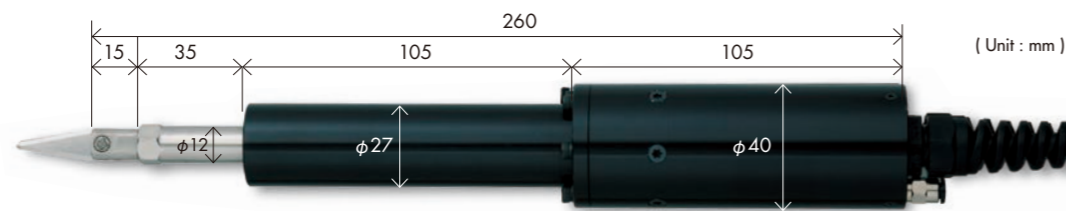

Standard Tools



Specifications: Transducer SF-7400

Frequency	22 kHz
Cord length	(Up to 10 m)
Housing material	Resin (Duracon)
Outer dimensions	φ16 / φ40 x 154L (mm)
Weight	340 g (excluding the cord)
Hand switch	Pushbutton type

Specifications: Transducer SF-3140

Frequency	22 kHz
Cord length	Up to 10 m
Housing material	Aluminum alloy
Outer dimensions	Hexagonal 12 / φ27 / φ40 x 260L (mm)
Weight	600 g (excluding the cord)
Blade thickness	0.6 mm

SONOFILE SF-30

HP-660

The effect of ultrasonic high-speed micro vibrations realized cutting of materials at will.

This is a high-frequency cutter featuring the 40 kHz (40,000 vibrations per second) vibration frequency of tools with an amplitude of 30 microns. It maximizes the effect of ultrasonic high-speed micro vibrations. A wide range of materials, including newly developed composite materials, rubber, and leather, can be cut at will with low processing pressure, sharp cutting surfaces, and little cutting chips.

Features

- Stable vibrations with a maximum amplitude of 30 microns ensure remarkable cutting performance.
- Light in weight and easy-to-hold transducer (150 g) where much greater importance is attached to its operating performance.
- Adoption of the exclusive square-head screws and the screwdriver ensures easy and robust mounting of tools.

Oscillator SF-30



Applicable Materials

- Rubber (vulcanized latex, non-vulcanized latex, sheeting materials, sealing materials and tubes) and leather (natural and artificial)
- Thermoplastics (boards, sheeting materials, films, laminated materials, flooring materials)
- Fabric materials, nonwoven fabrics and paper (specially treated paper and coated paper)

Specifications: Oscillator

Frequency adjustment	Automatic tracking type
Maximum output / Output adjustment	45 W / Two-step continuously-variable type
Power requirement	Single phase 100 VAC, 50/60 Hz
Power consumption	100 VA
Outer dimensions	Approx. 170 (W) x 180 (D) x 78 (H) (mm)
Weight	Approx. 1.5 kg

Transducer HP-660



Standard Tools



Specifications: Transducer

Frequency	40 kHz
Cord length	4 m
Housing material	Resin (Duracon)
Outer dimensions	φ10 / φ18.5 / φ28 x 150.6 L (mm)
Weight	150 g (excluding the cord)
Blade thickness	Dedicated for use with a 0.4 mm blade

* The tools can be chosen out of our abundant product lineups according to the intended use. We also design and manufacture custom-order tools. Specifications are subject to change without prior notice for continual improvements. Please confirm when placing your order.