



## ATTENTION !!

Before using out tools, observe the following general notes and read operation manual carefully for safety and correct operation.

### ★ "NILE" AIR TOOLS



- Keep air supply closed always while the tools are out of service for inspection, replacement of cutting blade and after use.
- As the air tools bellver extreme cutting and pressing power, NEVER touch the cutting blades orput the hands/fingers close to the cutting blade.
- Make sure to use safety glasses when operatingthe tools to protect operator,s eyes from flying cat pieces.
- Employ the recommended air pressure for operation. Higher air pressure will cause various troubles of the tools.



### ★ "MERRY" HAND TOOLS



- Do not apply the tools to cut unsuitable subjects. Unsuitable application of the tools will cause damage of the cutting blades and flying pieces of the broken pieces of the cutting blades.
- The cutting blades have very sharp cutting edges. Never touch the cutting blades or put the hands/fingers close to the cutting blades.
- Make sure to use safety glasses when operating the tools.



**IN ADDITION, STRICTLY OBSERVE YOUR LOCAL SAFETY REGULATIONS FOR CUTTING EQUIPMENTS.**

## NOTES TO USERS

Before using the tools, you should first thoroughly read the following warnings and cautions for safety and correct operation. In addition, observe strictly all your local safety regulations for cutting tools and related equipments.

### WARNINGS:

#### (Working conditions for air tools)

1. **Air pressure** : Supply recommended air pressure by using pressure gauges and control valves. Higher air pressure will cause damages and accidents.
2. **POwer source** : Use only air compressed by air compressors. Do not use any other power source, such as high pressure gas of oxygen, acetylene, propane, etc. which will cause explosive hazard.
3. **Air hose** : Use air hoses of proper size and quality to suit the tools and application. Air hoses should be oil-proof and abrasion-proof in quality. Do not use old and decrepit air hoses. Do not use excessively long air hose of more than 5M.
4. **Fittings for air hose** : Attach and fix all fittings securely to air hoses and air tools. Accidentally disconnected air hose, caused by imperfect fixing, flies around to cause hazard.

#### (Working environment)

1. **Keep working places sufficiently bright, clean and ordered** : Dark and/or disordered working places may cause accident.
2. **Never use air tools in or near any inflammable and explosive goods or environment.**

#### (Working wear)

1. **Put on proper and perfect-fitting working wear** : Do not put on loose or imperfect wear and such ornaments as necklaces. Put on working caps to set long hair off the tools.
2. **Use proper protective guards** such as helmets, safety glasses, earplugs, dust-proof masks, safety shoes, etc. to meet each job.

#### (Use of air tools)

1. **Securely fix the subject to work for with air tools.** Insufficiently-fixed work pieces may fly off to cause personal injury or material damage. **Do not put fingers/hands or cloth near to cutting blades or any other activating parts or accessories of air tools.** **Do not operate air tools in an irrational/unjustifiable physical posture.** Hold the tools securely and keep a stabilized working boody balance. **Do not make sudden start of operation.** **Make sure if the throttle valve of air tools is shut off when connecting to air hoses.** **Keep the throttle lever of air tools off while carrying the tools by hands.** **Do not make air tools contact electricity.** Air tools are not insulated. **Stop operation of air tools immediately when feeling any irregularity.** Have the tools checked carefully and repaired properly.
2. **Apply air tools only to recommended applications.** Never use air tools for unsuitable purpose/ application out of prescribed recommendations.
3. **Never make any modification of air tools by yourself.** The tools modified will cause accident.
4. **Do not remove any integrated parts off air tools.** Using air tools with any parts removed off may cause accident.
5. **Shut off air supply and disconnect air tools from the air hose when air tools are kept out of use.** when exchanging the attachments(cutting blades, files, saw blades, etc.), when the air tools are under maintenance service, and whenever any danger is anticipated.

### CAUTIONS:

#### (Essential cautions for use of air tools)

1. Pay full attention for safety operation of the air tools without rashly or thoughtless action.
2. Do not allow any out-of-duty persons, especially children, come close to the working place.
3. Use the air tools within the rated capacity. Over-loaded operation will cause damage and trouble of air tools.
4. Exhaust air should be directed not to hit eyes and years of persons around the working area.
5. Handle the air tools carefully without abuse. Shock given to air tools by throwing or dropping on the floor may cause accident or trouble.
6. Handle the air hose carefully. Do not use the air hose for the purpose of supporting or carrying air tools. Failed/damaged air hose will cause accident.
7. Pay sufficient care for air tools not in use. Store air tools, after maintaining properly, in a dried and out of reach of children place.

#### (Maintenance, inspection and repair)

1. Never forget to check air tools before using, make sure if all assembling screws and parts are well set and not damaged. Loosen screws and imperfect parts may cause lowered tool performance or accident.
2. Do not neglect to perform regular maintenance and inspection of air tools. Safety and effective use of the air tools is assured by regular maintenance and inspection practice.
3. Ask us direct or our authorized servicing centers for repair of air tools. We shall be free from liability for any accident or problem caused by repair or treatment of air tools made by any others.

## CONTENTS

STANDARD BLADES _____	1~2
SPECIAL BLADES _____	2~3
AIR CUTTERS (HAND-HELD) _____	4
MACHINE-FITTING TYPE AIR CUTTERS _____	5~11
SETTING TYPE AIR CUTTERS _____	12
HIGH POWER AIR CUTTERS _____	13
SLIDE & CUT TYPE AIR CUTTERS _____	14
VERTICAL TYPE AIR CUTTERS /	
GATE CUTTING TABLE / TIMING UNIT _____	15
GATE CUTTING AIR CUTTERS /	
AIR HEAT-CUTTERS _____	16
SLIDING AIR CUTTERS / AIR SQUEEZERS _	17
AIR FIL-SAWS / FILE SAW _____	18
AIR PLATE SHEARS /	
AIR MULTI-PURPOSE SCISSORS /	
AIR CORD BUSHER / AIR TWISTER _____	19
AIR CUTTERS(SET A SIDE-EDGED GOING)_	20
AIR SHEARS /	
MACHINE-FITTING TYPE AIR SHEARS _____	21
AIR SHOT-HAMMERS _____	22
CABLE STRIPPERS _____	23
MINI BELTER / WIRE TWISTER /	
CUTTING BENDER _____	24
STAND-HOLDER / FOOT VALVE /	
FIXING STAND _____	25
MERRY BRAND HAND TOOLS _____	27~29
PLASTIC CUTTING TOOLS _____	29
WIRES NIPPERS / COMPOUND NIPPERS /	
PC NIPPERS & PLIERS / DUCT CUTTERS _	30
HEAT NIPPERS / PALM GRIP NIPPERS _____	31
PLASTIC PIPE CUTTERS _____	32
MULTI-PURPOSE SNIP _____	33
DUCT CUTTERS / FLEKI-SNIP _____	34
CASSETTE PLIERS / MINI WIRE STRIPPER	
CABLE STRIPPER _____	35
BARRIER WRENCHES _____	36
GUIDANCE FOR CUTTING CAPACITY _____	37





# "NILE" BRAND AIR TOOLS !

## STANDARD BLADES FOR AIR CUTTERS (SHAPE & DIMENSIONS of BLADES)

### S Type : Standard Blades

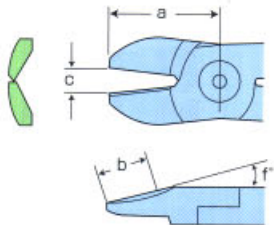

Blade No.	a	b	c	f'
S20	24	12	2.5	25
S2	24	12	3.0	25
S4	27	14	5.0	25
S5	35	17	6.5	30
S250	43	20	9.0	15
S7P	43	20	7.0	30
S7P1	43	20	5.5	30
S120	45	26	9.0	35

### P Type : Heavy-duty Z Type : Carbide tipped for hard wire

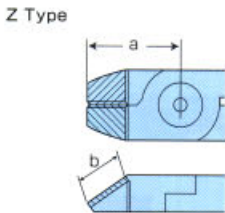
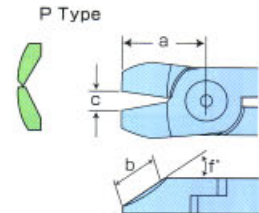

Blade No.	a	b	c	f'
P6	29	11	6.0	35
P8P	37	12	7.0	25
P8P1	37	12	5.0	25
P120	40	16	8.0	35
*Z20	24	11	2.5	25
*Z2	24	11	3.0	25
*Z4	27	10	5.0	25
*Z6	30	15	6.0	35
*Z8P	38	20	6.0	40
*Z120	40	17	7.0	35

\*Carbide tipped

### S~R Type : Sharp edge for copper or soft wire

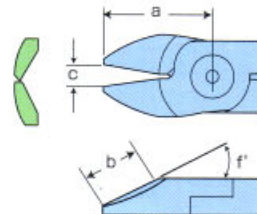

Blade No.	a	b	c	f'
S4R	27	14	5.0	25
S5R	35	17	6.5	30
S7PR	43	20	7.0	30

### S~S Type : Flat surface Z~S Type : Carbide tipped for hard wire

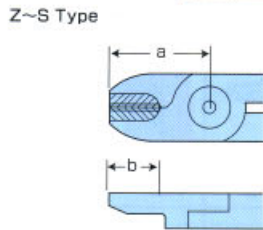
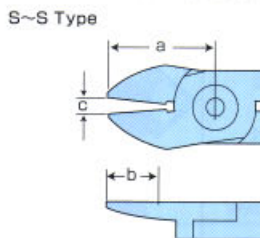

Blade No.	a	b	c
S20S	24	12	2.5
S2S	24	12	3.0
S4S	27	13	4.0
S5S	35	17	6.5
S250S	43	21	9.0
S7PS	43	20	7.0
S7P1S	43	22	7.0
S120S	55	30	11.0
*Z20S	24	11	2.5
*Z2S	24	10	3.0
*Z4S	27	11	5.0
*Z6S	34	17	6.0
*Z8PS	40	17	6.0
*Z120S	40	17	7.0

\*Carbide tipped

### CR Type : Clipper edge ZCR Type : Carbide tipped

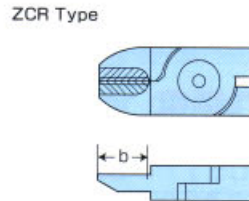
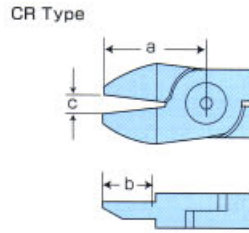

Blade No.	a	b	c
CR20	24	12	2.5
CR2	24	12	3.0
CR4	26.5	12	3.5
CR6	35	15	7.0
CR250	43	20	11.0
CR8P	43	20	7.0
CR8P1	44	20	7.0
CR120	55	28	10.0
*ZCR20	24	10	2.5
*ZCR2	24	10	3.0
*ZCR4	27	10	4.0
*ZCR6	35	16	7.0
*ZCR8P	38	16	7.0
*ZCR8P1	37	16	6.0
*ZCR120	40	16	7.0

\*Carbide tipped

### Y Type : Pincers

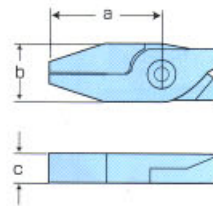

Blade No.	a	b	c
Y6	48	23	12
Y8P	65	36	17
Y120	60	50	25

### EP Type : End cutting edge ZEP Type : Carbide tipped

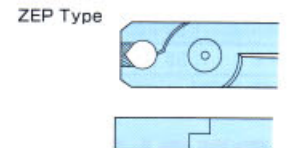
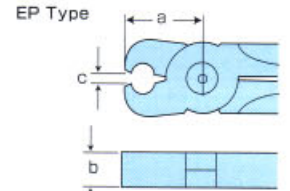

Blade No.	a	b	c
EP20, *ZEP20	20	7	2.0
EP2, *ZEP2	20	7	2.5
EP4, *ZEP4	26	9	5.0
EP6, *ZEP6	28	12	5.5
EP10P, *ZEP10P	34	17	5.5
EP10P1, *ZEP10P1	34	17	5.5
EP120, *ZEP120	40	25	8.0

\*Carbide tipped

### F Type : Plastic cutting ZF Type : Carbide tipped

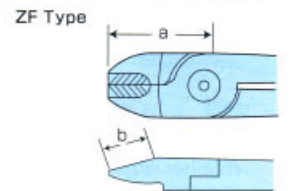
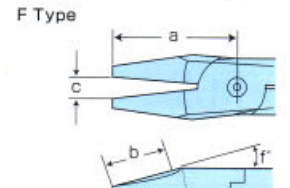

Blade No.	a	b	c	f'
F10	24	12	2.5	15
F1	24	12	3.0	15
F3	27	12	4.5	25
F5, *ZF5	35	15	8.5	15
F250	43	17	13.0	15
F9P	65	38	15.0	15
F9P1	65	33	9.0	15
F120	53	35	13.0	30

\*Carbide tipped



**FD Type** : Level cutting for plastic  
**ZFD Type** : Carbide tipped for hard plastic

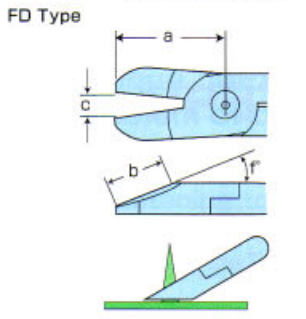

Blade No.	a	b	c	f'
FD10	24	10	2.5	40
FD1	24	10	3.0	40
FD3	27	10	4.5	40
FD5,*ZFD5	35	14	8.5	40
FD250	42	15	12.0	40
FD9P	59	27	14.0	30
FD9P1	59	23	9.0	30

\* Carbide tipped

**F~S Type** : Flat surface for plastic  
**ZF~S Type** : Carbide tipped for hard plastic

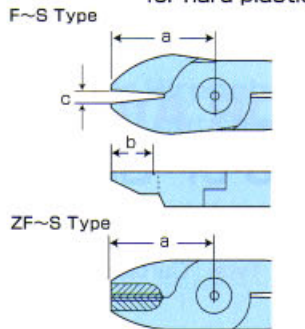

Blade No.	a	b	c
F10S	24	12	2.5
F1S	24	12	3.0
F3S	27	13	4.5
F5S,*ZF5S	35	16	8.5
F250S	43	21	11.5
F9PS	65	37	15.0
F9P1S	65	39	9.0

\* Carbide tipped

**F~LS Type** : Long blade

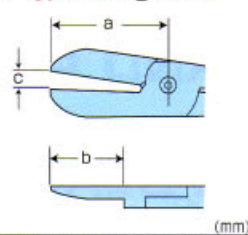

Blade No.	a	b	c
F3LS	50	30	8
F5LS	65	35	14

**FF Type** : Thin edge

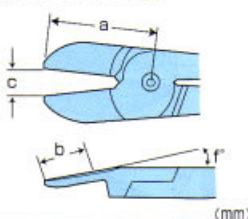

Blade No.	a	b	c	f'
FF3	27	12	4.5	25
FF5	35	15	8.5	15

**A Type** : Crimping

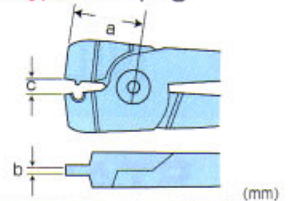

Blade No.	a	b	c
A8P-1.25	31	5.8	6.0
A8P-2.0	31	5.8	6.0
A8P-5.5	33	6.0	6.5

**AR Type** : Crimping

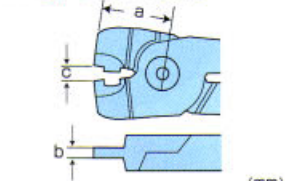

Blade No.	a	b	c
AR8P-1.25	32	6.5	6.5
AR8P-2.0	34	6.5	7.0
AR8P-5.5	36	6.5	7.0

## SPECIAL BLADES

Even a piece of any type of special blade can be designed and manufactured to meet your particular application. Samples of actual work pieces are required on inquiry for designing and quoting.

 Punching in rubberer	 Punching irregular holes	 Punching semicircle holes	 Punching triangle holes	 Punching twin holes
 At hard to reach places	 Radius cutting of plastics	 Machine-installed type for plastics cutting	 Plastic cutting	
 Fixing nut retainer rings	 Hex. forming on pipe end	 Quadruple caulking	 Caulking steel or copper plates	 Caulking steel or wood plates
 Unusual caulking	 Caulking aluminum sash	 Caulking round bands	 Caulking attachments	 Unusual caulking
 Bending steel plates	 Instant cutting / crashing of copper wire	 Deforming wire for retention	 Inserting rubber caps	 Driving keys



# SPECIAL BLADES

Some examples of custom-made blades  
(Designed to meet your particular application.)

## CAULKING (for sash etc.)

## CAULKING / CRASHING / BENDING

## PUNCHING / CRIMPING

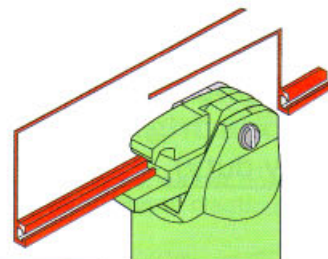
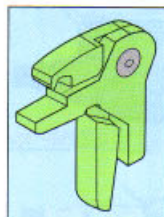
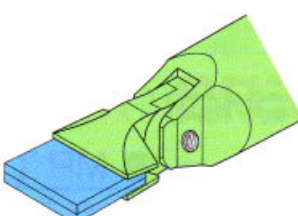
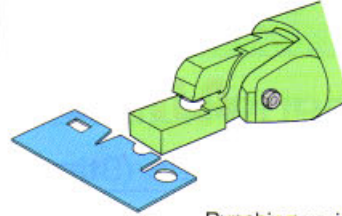
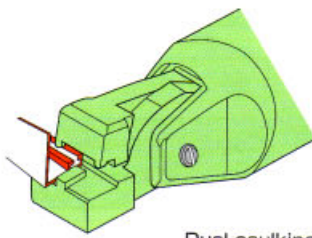
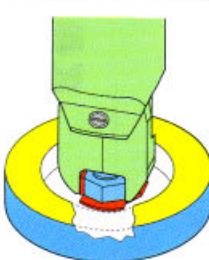
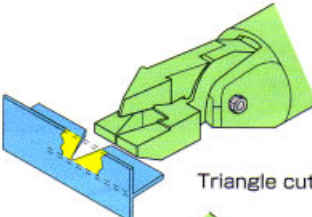
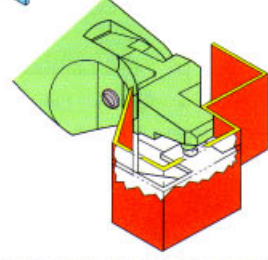
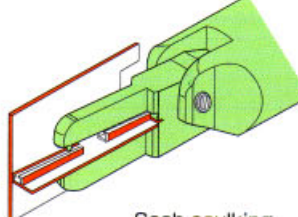
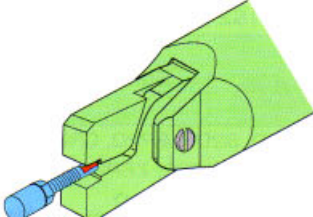
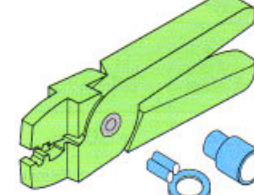
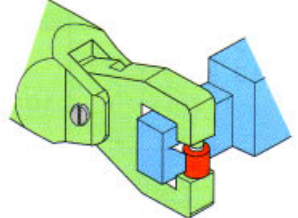
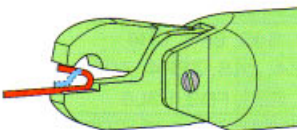
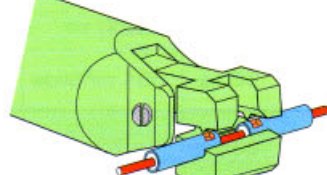
  <p>Side caulking</p>	 <p>Stretch-joining</p>	 <p>Punching various holes</p>
 <p>Dual caulking</p>	 <p>Washer caulking</p>	 <p>Triangle cutting-off</p>  <p>Punching holes in limited space</p>
 <p>Sash caulking</p>	 <p>Screw crashing</p>	 <p>Terminal crimping (either naked or insulated)</p>
 <p>Pin caulking</p>	 <p>Wire bending</p>	 <p>Dual crimping</p>

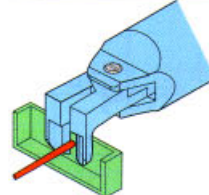
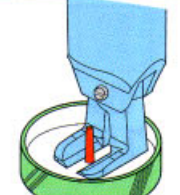
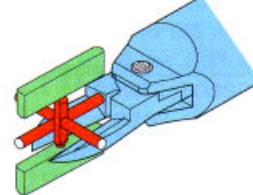
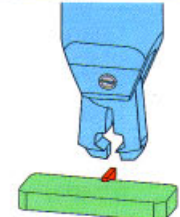
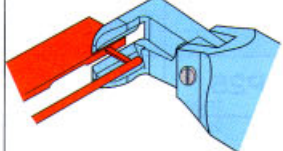
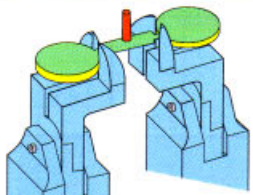
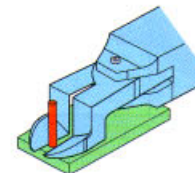
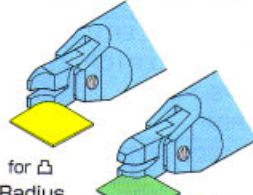
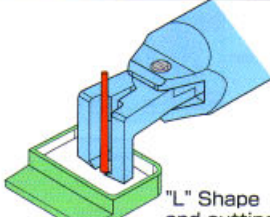
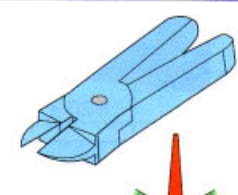
 <p>"L" Shape Internal blade</p>	 <p>"L" Shape external blade</p>	 <p>Long nose blade</p>	 <p>For cutting off</p>	 <p>For plate gate cutting</p>
 <p>Crank shape Internal blade</p>	 <p>Crank shape external blade</p>	 <p>for <math>\cup</math> Radius cutting</p> <p>for <math>\cap</math> Radius cutting</p>	 <p>"L" Shape end cutting blade</p>	 <p>Angular blade for quick bite-cutting</p>



Here is a wide range of "NILE" air cutters to help you achieve higher productivity and remarkable cost saving in cutting, squeezing, pressing, bending and punching jobs for modern industries. Equipped with different types of replaceable cutting blades, these air cutters can be versatile for various applications.

## AIR CUTTERS <HAND-HELD>

### ● MR Type (Standard)

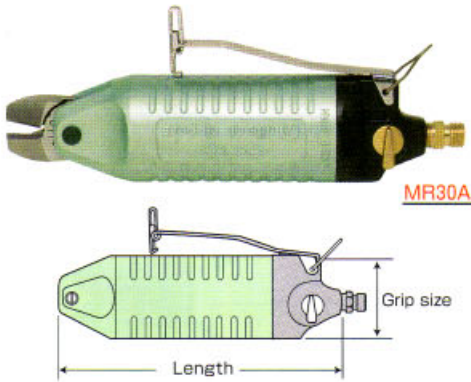

### ● MP Type (Heavy-duty)

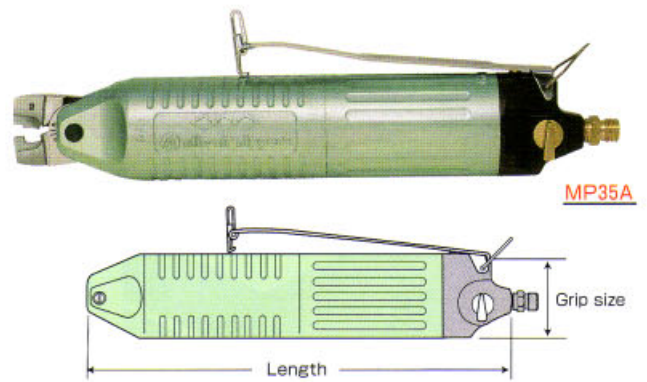

★ Refer to P.(1&2) for detailed information of cutting blades.

Model No.	Length Weight	Grip size Air consumption	Power (approx.) Air pressure	Blade No. * Carbide tipped	Cutting capacity					
					Steel wire	Copper wire	Piano wire	Crimp-ing	Plastics Soft Hard	φ mm
MR3	112 mm	φ 20 mm	265 N	S20, S20S, EP20, CR20	0.5	0.8	—	—	—	—
	90 g	35 cm <sup>3</sup> /Stroke	0.4~0.5 MPa	* Z20, Z20S, ZEP20, ZCR20	0.5	0.8	0.2	—	—	—
				F10, F10S, FD10	—	—	—	—	1.0	—
MR5	103 mm	φ 30 mm	390 N	S2, S2S, EP2, CR2	0.5	1.0	—	—	—	—
	130 g	64 cm <sup>3</sup> /Stroke	0.4~0.5 MPa	* Z2, Z2S, ZEP2, ZCR2	0.5	1.0	0.3	—	—	2.0
				F1, F1S, FD1	—	—	—	—	—	—
MR10	124 mm	φ 36 mm	580 N	S4, S4S, EP4, CR4	1.0	1.6	—	—	—	—
	200 g	116 cm <sup>3</sup> /Stroke	0.4~0.5 MPa	* Z4, Z4S, ZEP4, ZCR4	1.0	1.6	0.5	—	—	—
				F3, F3S, FD3, F3LS	—	—	—	—	4.0	2.6
MR20	155 mm	φ 45 mm	1,370 N	S5, S5S, P6, EP6, CR6	2.0	2.6	—	—	—	—
	340 g	230 cm <sup>3</sup> /Stroke	0.5~0.6 MPa	* Z6, Z6S, ZEP6, ZCR6	2.0	2.6	1.0	—	—	—
				F5, F5S, FD5, F5LS	—	—	—	—	7.0	5.0
MR30A	191 mm	φ 56 mm	2,740 N	S7P, S7PS, P8P, EP10P, CR8P	2.8	3.3	—	—	—	—
				* Z8P, Z8PS, ZEP10P, ZCR8P	2.8	3.3	1.2	—	—	—
	520 g	584 cm <sup>3</sup> /Stroke	0.5~0.6 MPa	F9P, F9PS, FD9P	—	—	—	—	10.0	6.5
				A8P, AR8P	—	—	—	1.25/2.0	—	—
MR50A	256 mm	φ 75 mm	4,700 N	S120, S120S, P120, EP120, CR120	4.5	5.5	—	—	—	—
	1,290g	1,170cm <sup>3</sup> /Stroke	0.5~0.6 MPa	* Z120, Z120S, ZEP120, ZCR120	4.5	5.5	1.6	—	—	—
				F120 A120, AR120	—	—	—	—	11.0	8.0
MR50F	214 mm 1,170g	φ 75 mm 1,100cm <sup>3</sup> /Stroke	4,100 N 0.5~0.6 MPa	F9PF, FD9PF	—	—	—	—	12.0	6.5
MP25A	227 mm	φ 45 mm	1,960 N	S5, S5S, P6, EP6, CR6	2.0	2.6	—	—	—	—
	560 g	400 cm <sup>3</sup> /Stroke	0.4~0.5 MPa	* Z6, Z6S, ZEP6, ZCR6	2.0	2.6	1.0	—	—	—
				F5, F5S, FD5, F5LS	—	—	—	—	7.0	5.0
MP25	190 mm	φ 45 mm	1,560 N	S250, S250S, CR250	1.8	2.4	—	—	—	—
	480 g	508 cm <sup>3</sup> /Stroke	0.5~0.6 MPa	F250, F250S, FD250	—	—	—	—	8.0	5.0
MP250	234 mm	φ 45 mm	2,740 N	S7P1, S7P1S, P8P1, EP10P1, CR8P1	3.2	4.0	—	—	—	—
				* Z8P1, ZEP10P1, ZCR8P1,	3.2	4.0	1.2	—	—	—
	560 g	508 cm <sup>3</sup> /Stroke	0.5~0.6 MPa	F9P1, F9P1S, FD9P1	—	—	—	—	8.0	6.5
				A8P1, AR8P1	—	—	—	1.25/2.0	—	—
MP35A	268 mm	φ 56 mm	4,410 N	S7P, S7PS, P8P, EP10P, CR8P	4.0	4.8	—	—	—	—
				* Z8P, Z8PS, ZEP10P, ZCR8P	4.0	4.8	1.2	—	—	—
	830 g	956 cm <sup>3</sup> /Stroke	0.5~0.6 MPa	F9P, F9PS, FD9P	—	—	—	—	13.0	6.5
				A8P, AR8P	—	—	—	2.0/5.5	—	—
MP55A	372 mm	φ 75 mm	7,740 N	S120, S120S, P120, EP120, CR120	6.0	7.0	—	—	—	—
				* Z120, Z120S, ZEP120, ZCR120	6.0	7.0	2.0	—	—	—
	2,000g	2,670cm <sup>3</sup> /Stroke	0.5~0.6 MPa	F120	—	—	—	—	11.0	8.0
				A120, AR120	—	—	—	8.0	—	—



# MACHINE-FITTING TYPE AIR CUTTERS

Optimum for mounting  
on automatic machine !

## ● MR ~ M Type

## ● MP ~ M Type



MR20M



MP35AM

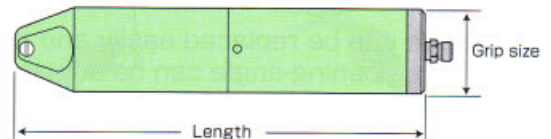
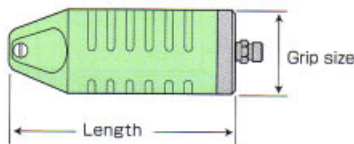

★ Refer to P.(1&2 ) for detailed information of cutting blades.

Model No.	Length Weight	Grip size Air consumption	Power (approx.) Air pressure	Blade No. * Carbide tipped	Cutting capacity					φ mm	
					Steel wire	Copper wire	Piano wire	Crimp-ing	Plastics Soft	Plastics Hard	
MR3M	101 mm	φ 20 mm	265 N	S20, S20S, EP20, CR20	0.5	0.8	—	—	—	—	—
	70 g	35 cm <sup>3</sup> /Stroke	0.4~0.5 MPa	* Z20, Z20S, ZEP20, ZCR20 F10, F10S, FD10	0.5	0.8	0.2	—	—	1.0	—
MR5M	84 mm	φ 30 mm	390 N	S2, S2S, EP2, CR2	0.5	1.0	—	—	—	—	—
	100 g	64 cm <sup>3</sup> /Stroke	0.4~0.5 MPa	* Z2, Z2S, ZEP2, ZCR2 F1, F1S, FD1	0.5	1.0	0.3	—	—	2.0	—
MR10M	105 mm	φ 36 mm	580 N	S4, S4S, EP4, CR4	1.0	1.6	—	—	—	—	—
	160 g	116 cm <sup>3</sup> /Stroke	0.4~0.5 MPa	* Z4, Z4S, ZEP4, ZCR4 F3, F3S, FD3, F3LS	1.0	1.6	0.5	—	—	4.0	2.6
MR20M	121 mm	φ 45 mm	1,370 N	S5, S5S, P6, EP6, CR6	2.0	2.6	—	—	—	—	—
	270 g	230 cm <sup>3</sup> /Stroke	0.5~0.6 MPa	* Z6, Z6S, ZEP6, ZCR6 F5, F5S, FD5, F5LS	2.0	2.6	1.0	—	—	7.0	5.0
MR30AM	157 mm	φ 56 mm	2,740 N	S7P, S7PS, P8P, EP10P, CR8P	2.8	3.3	—	—	—	—	—
	470 g	584 cm <sup>3</sup> /Stroke	0.5~0.6 MPa	* Z8P, Z8PS, ZEP10P, ZCR8P F9P, F9PS, FD9P	2.8	3.3	1.2	—	—	10.0	6.5
MR50AM	215 mm	φ 75 mm	4,700 N	S120, S120S, P120, EP120, CR120	4.5	5.5	—	—	—	—	—
	1,180g	1,170cm <sup>3</sup> /Stroke	0.5~0.6 MPa	* Z120, Z120S, ZEP120, ZCR120 F120	4.5	5.5	1.6	—	—	11.0	8.0
MR50FM	173 mm 1,040g	φ 75 mm 1,100cm <sup>3</sup> /Stroke	4,100 N 0.5~0.6 MPa	F9PF, FD9PF	—	—	—	—	—	12.0	6.5
MP25M	170 mm	φ 45 mm	1,560 N	S250, S250S, CR250	1.8	2.4	—	—	—	—	—
	450 g	508 cm <sup>3</sup> /Stroke	0.5~0.6 MPa	F250, F250S, FD250	—	—	—	—	—	8.0	5.0
MP25AM	208 mm	φ 45 mm	1,960 N	S5, S5S, P6, EP6, CR6	2.0	2.6	—	—	—	—	—
	480 g	400 cm <sup>3</sup> /Stroke	0.4~0.5 MPa	* Z6, Z6S, ZEP6, ZCR6 F5, F5S, FD5, F5LS	2.0	2.6	1.0	—	—	7.0	5.0
MP250M	216 mm	φ 45 mm	2,740 N	S7P1, S7P1S, P8P1, EP10P1, CR8P1	3.2	4.0	—	—	—	—	—
	510 g	508 cm <sup>3</sup> /Stroke	0.5~0.6 MPa	* Z8P1, ZEP10P1, ZCR8P1, F9P1, F9P1S, FD9P1	3.2	4.0	1.2	—	—	8.0	6.5
MP35AM	249 mm	φ 56 mm	4,410 N	S7P, S7PS, P8P, EP10P, CR8P	4.0	4.8	—	—	—	—	—
	790 g	956 cm <sup>3</sup> /Stroke	0.5~0.6 MPa	* Z8P, Z8PS, ZEP10P, ZCR8P F9P, F9PS, FD9P	4.0	4.8	1.2	—	—	13.0	6.5
MP55AM	348 mm	φ 75 mm	7,740 N	S120, S120S, P120, EP120, CR120	6.0	7.0	—	—	—	—	—
	2,000g	2,670cm <sup>3</sup> /Stroke	0.5~0.6 MPa	* Z120, Z120S, ZEP120, ZCR120 F120	6.0	7.0	2.0	—	—	11.0	8.0



# MACHINE-FITTING TYPE AIR CUTTERS

## ● MR~MG, MP~MG Type

**NO TOOL IS NEEDED FOR  
BLADE REPLACEMENT !**

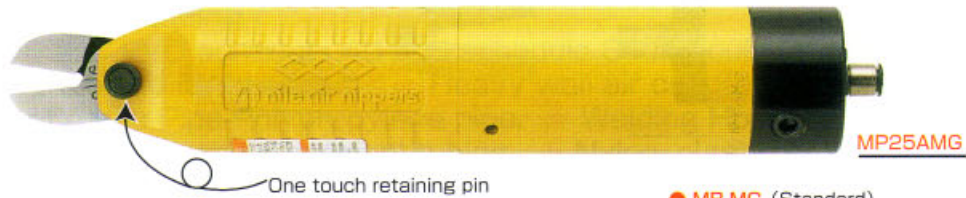
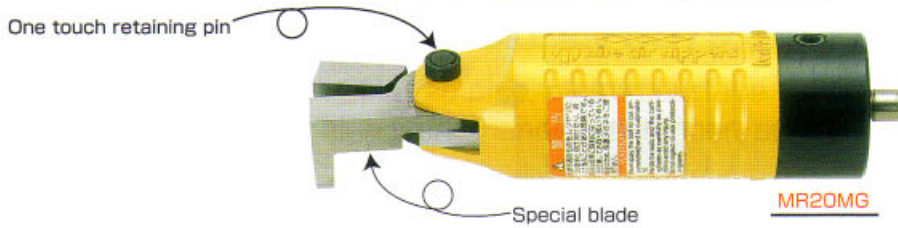

- ◆ Blade can be replaced easily and quickly.
- ◆ Blade opening-angle can be adjusted.

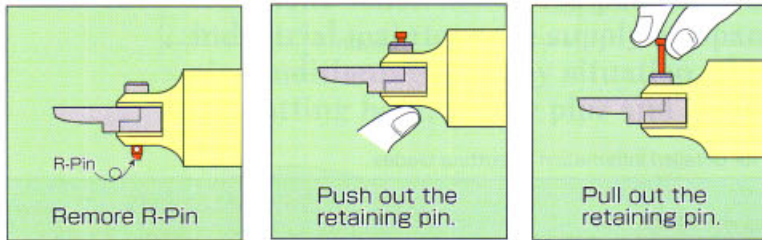

○ Be sure to secure Retaining Pin with R-Pin attached when Retaining Pin is likely to suffer some drawing-out power or shock. (R-Pin is designed for easy removal.)

### ● MR-MG (Standard)

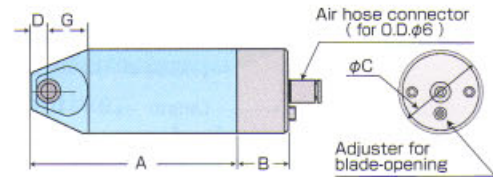

### ● MP-MG (Heavy-duty)

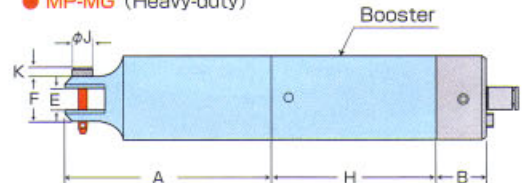

## ● MR~MT Type

**NO TOOL IS NEEDED FOR  
BLADE REPLACEMENT !**

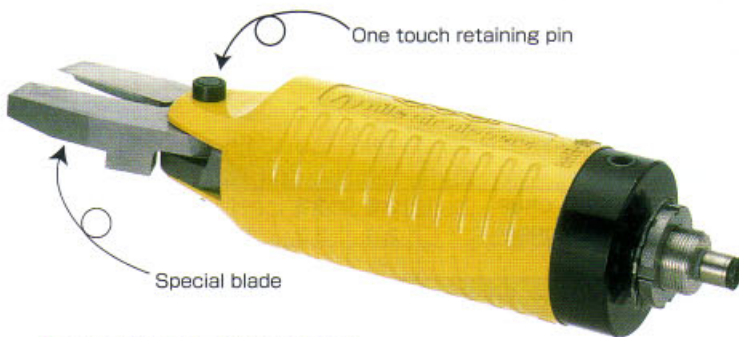

○ All cutting blades for MR-series can be applicable in common.

### SETTING EXAMPLE

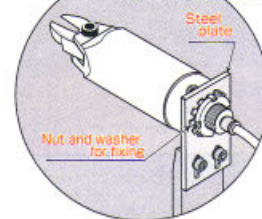

### ● MR-MT

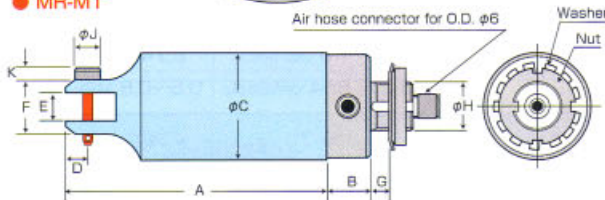

### Dimensions (mm)

Model No.	A	B	C	D	E	F	G	H	J	K
MR20MG	109	27	45	9	12	23	22	—	11	5
MP25AMG	109	27	45	9	12	23	22	87	11	5
MR30AMG	145	27	56	10	17	30	30	—	12	5
MP35AMG	145	27	56	10	17	30	30	92	12	5
MR20MT	109	18	45	9	12	23	10	20	11	5
MR30AMT	145	18	56	10	17	30	10	20	12	5

### ● F,S Type

### ● F-S, S-S Type

### ● CR Type

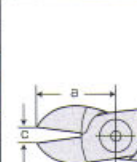

Blade No.	a	b	c
F5,F5S	35	15	8.5
S5,S5S	35	17	6.5
F9P	65	38	15.0
F9PS	65	37	15.0
S7P	43	20	7.0
CR8P	43	20	7.0



# MACHINE-FITTING TYPE

## DOUBLE-ACTION AIR CUTTERS

### ● WS Type

**NO TOOL IS NEEDED FOR BLADE REPLACEMENT!**

Spring-less blades are equipped to WS-Type air cutters!

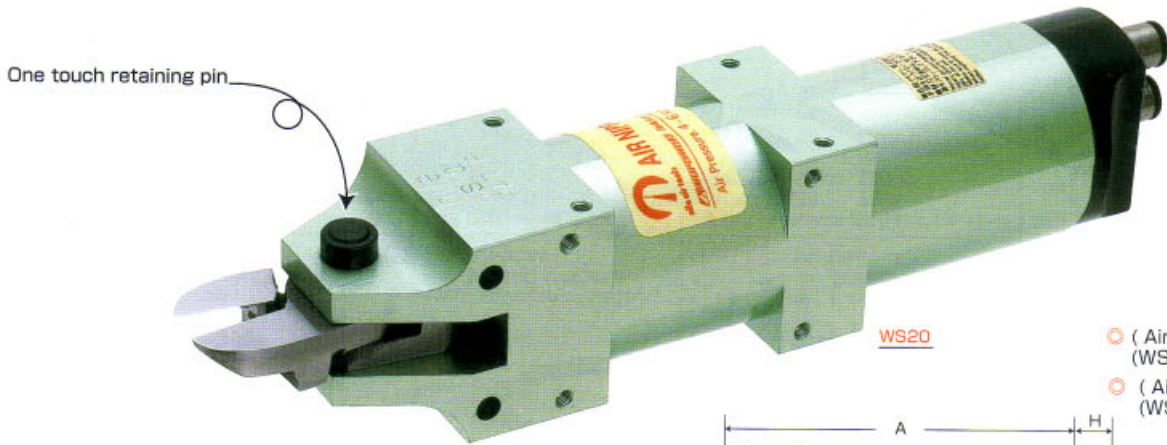

### FEATURES

- ◆ Trouble-free from spring damage.
- ◆ Quick and easy replacement of blades by hands without using any tool.
- ◆ Opening angles of blades can be adjusted (except WS3 type.)

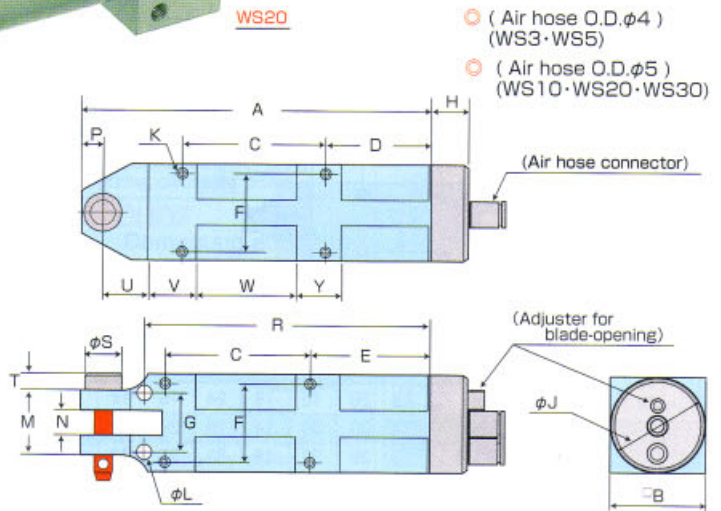

Dimensions

Model No.	A	B	C	D	E	F	G	H	J	K	L	M	N	P	R	S	T	U	V	W	Y
WS3	107	20	43	34	39	16	14	6	20	M3	3.3	20	7	7	89	11	5	3	24	30	13
WS5	104	30	43	31	36	24	18	11	30	M3	4.3	20	7	7	84	11	5	13	14	30	13
WS10	142	36	55	42	47	28	28	18	36	M4	4.3	23	9	7	114	11	5	16	27	40	15
WS20	170	45	55	65	70	36	30	18	45	M4	5.3	26	12	9	142	11	5	15	31	40	20
WS30	223	56	80	73	83	46	40	21	56	M5	5.3	36	17	15	183	12	5	20	41	50	37

Model No.	Weight		Power (approx.)		Blade No.	Cutting capacity $\phi$ mm		
	Air consumption		Air pressure			Steel wire	Copper wire	Plastics
WS3	88 g		265 N		FW10, FW10S	—	—	1.0
	39 cm <sup>3</sup> /Stroke		0.4~0.5 MPa		SW20, SW20S	0.5	0.8	—
WS5	179 g		390 N		FW1, FW1S	—	—	2.0
	65 cm <sup>3</sup> /Stroke		0.4~0.5 MPa		SW2, SW2S	0.5	1.0	—
WS10	309 g		580 N		FW3, FW3S	—	—	4.0
	198 cm <sup>3</sup> /Stroke		0.4~0.5 MPa		SW4, SW4S	1.0	1.6	—
WS20	537 g		1,370 N		FW5, FW5S	—	—	7.0
	567 cm <sup>3</sup> /Stroke		0.5~0.6 MPa		SW5, SW5S	2.0	2.6	—
WS30	1,050 g		2,740 N		FW9P, FW9PS	—	—	10.0
	1,045 cm <sup>3</sup> /Stroke		0.5~0.6 MPa					

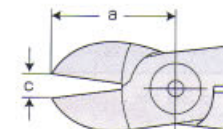

● FW, SW Type



● FW-S, SW-S Type

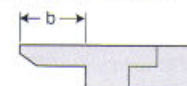

Blade No.	a	b	c
FW10	24	13	3.0
FW10S	24	13	3.0
FW1	24	13	3.5
FW1S	24	13	3.5
FW3	27	14	5.5
FW3S	27	13	5.5
FW5	35	19	8.5
FW5S	35	16	8.5
FW9P	66	38	15.0
FW9PS	65	37	15.0
SW20	24	10	3.0
SW20S	24	12	3.0
SW2	24	10	3.5
SW2S	24	12	3.5
SW4	27	13	5.5
SW4S	27	13	5.5
SW5	35	20	8.5
SW5S	35	16	8.5



# MACHINE-FITTING TYPE

## SQUARE AIR CUTTERS

The square body has many holes for setting bolts to be mounted on any machines or stands.

### ● MS Type

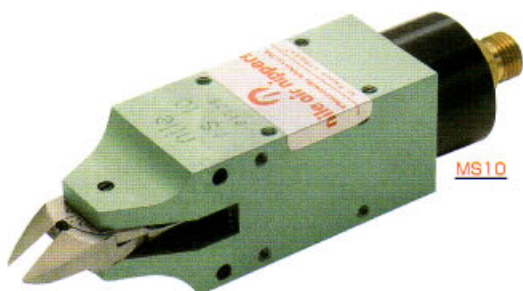

### ● MSP Type



#### ● MS (Standard)

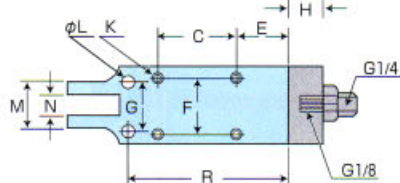
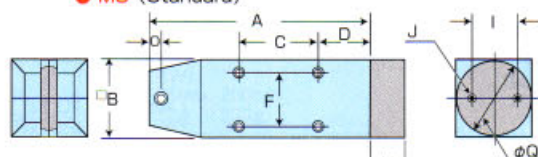

#### ● MSP (Heavy-duty)



Dimensions

○ All cutting blades for MR-series can be applicable in common.

(mm)

Model No.	A	B	C	D	E	F	G	H	I	J	K	L	M	N	O	P	Q	R
MS3	89	20	40	19	24	16	14	21	14	M3	M3	3.3	20	7	7	—	—	71
MS5	74	30	30	14	19	24	20	20	20	M4	M3	4.3	20	7	7	—	—	55
MS10	93	36	30	18	23	28	28	20	24	M4	M4	4.3	20	9	7	—	—	65
MS20	109	45	40	19	24	36	30	20	30	M5	M4	5.3	26	12	9	—	—	81
MS30	150	56	60	20	30	46	40	20	40	M6	M5	5.3	36	17	15	—	—	110
MSP20	109	45	40	19	24	36	30	20	30	M5	M4	5.3	26	12	9	87	45	81
MSP30	150	56	60	20	30	46	40	20	40	M6	M5	5.3	36	17	15	92	56	110

Model No.	Length Weight	Grip size Air consumption	Power (approx.) Air pressure	Blade No. * Carbide tipped	Cutting capacity $\phi$ mm				
					Steel wire	Copper wire	Piano wire	Plastics Soft	Hard
MS3	110 mm	$\phi$ 20 mm	265 N	S20, S20S, EP20, CR20	0.5	0.8	—	—	—
	100 g	35 cm <sup>3</sup> /Stroke	0.4~0.5 MPa	* Z20, Z20S	0.5	0.8	0.2	—	—
				F10, F10S, FD10	—	—	—	1.0	—
MS5	94 mm	$\phi$ 30 mm	390 N	S2, S2S, EP2, CR2	0.5	1.0	—	—	—
	160 g	64 cm <sup>3</sup> /Stroke	0.4~0.5 MPa	* Z2, Z2S	0.5	1.0	0.3	—	—
				F1, F1S, FD1	—	—	—	2.0	—
MS10	113 mm	$\phi$ 36 mm	580 N	S4, S4S, CR4, EP4	1.0	1.6	—	—	—
	260 g	116 cm <sup>3</sup> /Stroke	0.4~0.5 MPa	* Z4, Z4S	1.0	1.6	0.5	—	—
				F3, F3S, FD3	—	—	—	4.0	2.6
MS20	129 mm	$\phi$ 45 mm	1,370 N	S5, S5S, CR6, EP6	2.0	2.6	—	—	—
	430 g	230 cm <sup>3</sup> /Stroke	0.5~0.6 MPa	* Z6, Z6S	2.0	2.6	1.0	—	—
				F5, F5S, FD5	—	—	—	7.0	5.0
MS30	170 mm	$\phi$ 56 mm	2,740 N	S7P, P8P, CR8P, EP10P	2.8	3.3	—	—	—
	810 g	584 cm <sup>3</sup> /Stroke	0.5~0.6 MPa	* Z8P, ZCR8P	2.8	3.3	1.2	—	—
				F9P, F9PS, FD9P	—	—	—	10.0	6.5
MSP20	216 mm	$\phi$ 45 mm	1,960 N	S5, S5S, CR6, EP6	2.0	2.6	—	—	—
	650 g	400 cm <sup>3</sup> /Stroke	0.4~0.5 MPa	* Z6, Z6S	2.0	2.6	1.0	—	—
				F5, F5S, FD5	—	—	—	7.0	5.0
MSP30	262 mm	$\phi$ 56 mm	4,410 N	S7P, P8P, CR8P, EP10P	4.0	4.8	—	—	—
	1,220 g	956 cm <sup>3</sup> /Stroke	0.5~0.6 MPa	* Z8P, ZCR8P	4.0	4.8	1.2	—	—
				F9P, F9PS, FD9P	—	—	—	13.0	6.5



# MACHINE-FITTING TYPE SQUARE AIR CUTTERS

● MS~G, MSP~G Type

**NO TOOL IS NEEDED FOR  
BLADE REPLACEMENT!**

The square main body has numerous holes for setting bolts,

One touch retaining pin

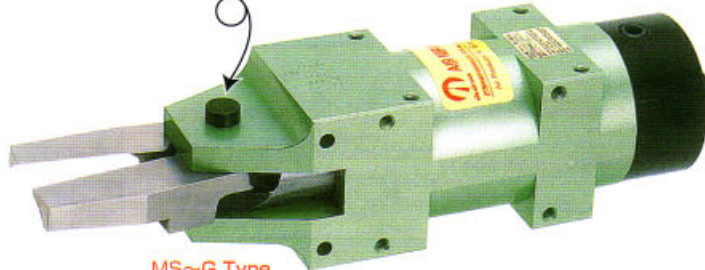

**MS~G Type**  
(Standard)

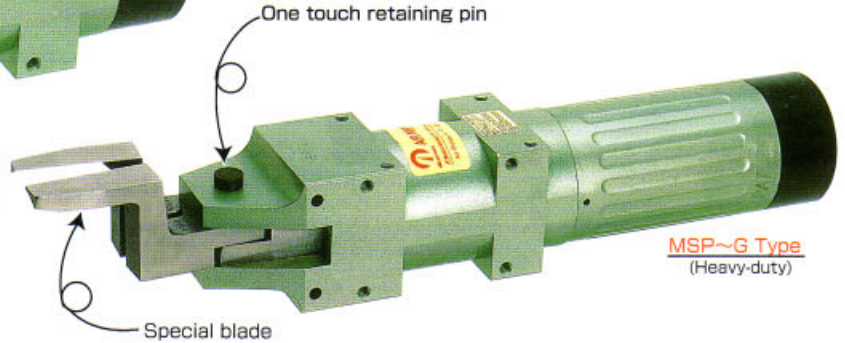

**MSP~G Type**  
(Heavy-duty)

- ◆ Blade can be replaced easily and quickly.
- ◆ Blade opening-angle can be adjusted (except MS3G type)

● **MS-G** (Standard type)

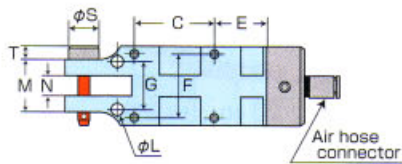
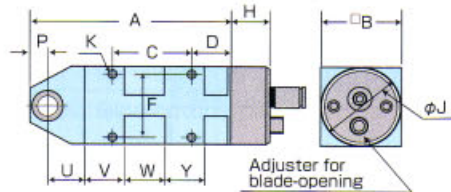

● **MSP-G** (Heavy-duty type)

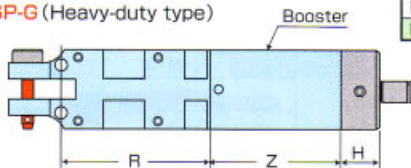

■ Air hose O.D.  $\phi 4$  = MS3G·MS5G

■ Air hose O.D.  $\phi 6$  = MS10G·MS10AG·MS20G·MSP20G·MS30G·MSP30G

Blades for MS-G and MSP-G are used in common with MR and MP series. Refer to P.(1&2) for information of standard blades.

○ All cutting blades for MR-series can be applicable in common.

Dimensions

Model No.	A	B	C	D	E	F	G	H	J	K	L	M	N	P	R	S	T	U	V	W	Y	Z
MS3G	89	20	40	19	24	16	14	12	20	M3	3.3	20	7	7	71	11	5	3	25	25	15	—
MS5G	74	30	30	14	19	24	18	15	30	M3	4.3	20	7	7	54	11	5	13	15	15	15	—
MS10G	93	36	30	18	23	28	28	24	36	M4	4.3	23	9	7	65	11	5	16	27	15	15	—
MS10AG	93	36	30	18	23	28	28	24	36	M4	4.3	26	12	7	65	11	5	16	27	15	15	—
MS20G	109	45	40	19	24	36	30	27	45	M4	5.3	26	12	9	81	11	5	15	31	25	15	—
MS30G	150	56	60	20	30	46	40	27	56	M5	5.3	36	17	15	110	12	5	20	41	38	22	—
MSP20G	109	45	40	19	24	36	30	27	45	M4	5.3	26	12	9	81	11	5	15	31	25	15	87
MSP30G	150	56	60	20	30	46	40	27	56	M5	5.3	36	17	15	110	12	5	20	41	38	22	92

(mm)

● **F,S Type**

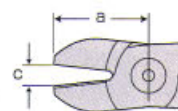

● **F-S, S-S Type**

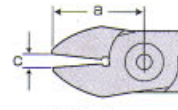

● **CR Type**

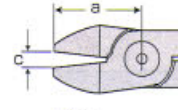

Blade No.	a	b	c
F10	24	12	2.5
F10S	24	12	2.5
F1	24	12	3.0
F1S	24	12	3.0
F3	27	12	4.5
F3S	27	13	4.5
F5A	35	15	5.0
F5AS	35	16	5.0
F5	35	15	8.5
F5S	35	16	8.5
F9P	65	38	15.0
F9PS	65	37	15.0

S20	24	12	2.5
S20S	24	12	2.5
S2	24	12	3.0
S2S	24	12	3.0
S4	27	14	5.0
S4S	27	13	4.0
S5A	35	22	4.5
S5AS	35	17	4.5
S5	35	17	6.5
S5S	35	17	6.5
S7P	43	20	7.0
CR8P	43	20	7.0

Model No.	Weight		Power (approx.) Air pressure	Blade No.	Cutting capacity $\phi$ mm			
	Air consumption				Steel wire	Copper wire	Plastics Soft Hard	
MS3G	75 g	265 N	0.4~0.5MPa	F10, F10S	—	—	1.0	—
	35 cm <sup>3</sup> /Stroke			S20, S20S	0.5	0.8	—	—
MS5G	141 g	390 N	0.4~0.5MPa	F1, F1S	—	—	2.0	—
	64 cm <sup>3</sup> /Stroke			S2, S2S	0.5	1.0	—	—
MS10G	254 g	580 N	0.4~0.5MPa	F3, F3S	—	—	4.0	2.6
	116 cm <sup>3</sup> /Stroke			S4, S4S	1.0	1.6	—	—
MS10AG	248 g	580 N	0.4~0.6MPa	F5A, F5AS	—	—	5.0	2.6
	116 cm <sup>3</sup> /Stroke			S5A, S5AS	1.2	1.8	—	—
MS20G	425 g	1,370 N	0.5~0.6MPa	F5, F5S	—	—	7.0	5.0
	230 cm <sup>3</sup> /Stroke			S5, S5S	2.0	2.6	—	—
MS30G	788 g	2,740 N	0.5~0.6MPa	F9P, F9PS	—	—	10.0	6.5
	584 cm <sup>3</sup> /Stroke			S7P, CR8P	2.8	3.3	—	—
MSP20G	648 g	1,960 N	0.4~0.5MPa	F5, F5S	—	—	7.0	5.0
	400 cm <sup>3</sup> /Stroke			S5, S5S	2.0	2.6	—	—
MSP30G	1,115 g	4,410 N	0.5~0.6MPa	F9P, F9PS	—	—	13.0	6.5
	956 cm <sup>3</sup> /Stroke			S7P, CR8P	4.0	4.8	—	—



# MACHINE-FITTING TYPE AIR CUTTERS

## ● MSK Type

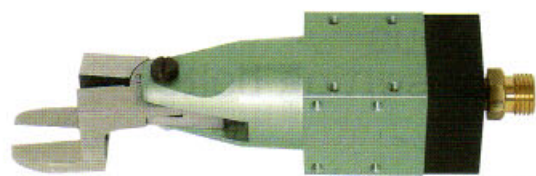

MSK10

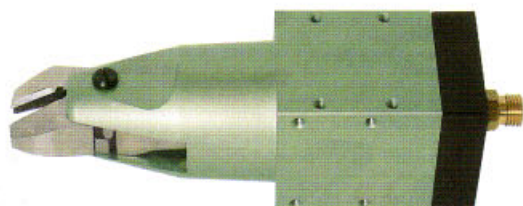

MSK20

○ All cutting blades for MR-series can be applicable in common.

### ● MSK

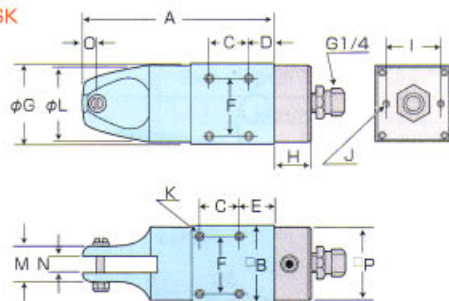

Dimensions

(mm)

Model No.	A	B	C	D	E	F	G	H	I	J	K	L	M	N	O	P
MSK10	87	36	18	10	15	28	35	17	24	M4	M4	33	18	9	7	35
MSK20	102	45	20	15	20	36	44	17	30	M5	M4	42	24	12	9	44
MSK30	141	56	27	18	26	46	55	17	40	M6	M5	52	34	17	15	55

Model No.	Length	Grip size	Power (approx.)	Blade No.	Cutting capacity			
					Steel wire	Copper wire	Piano wire	Plastics
MSK10	104 mm	φ 36 mm	580 N	S4, S4S	1.0	1.6	—	—
	190 g	116 cm <sup>3</sup> /Stroke	0.4~0.5 MPa	* Z4, Z4S F3, F3S, FD3	1.0	1.6	0.5	4.0 2.6
MSK20	119 mm	φ 45 mm	1,370 N	S5, S5S, P6, CR6	2.0	2.6	—	—
	340 g	230 cm <sup>3</sup> /Stroke	0.5~0.6 MPa	* Z6, Z6S F5, F5S, FD5	2.0	2.6	1.0	7.0 5.0
MSK30	158 mm	φ 56 mm	2,740 N	S7P, P8P, CR8P	2.8	3.3	—	—
	590 g	584 cm <sup>3</sup> /Stroke	0.5~0.6 MPa	* Z8P F9P, F9PS, FD9P	2.8	3.3	1.2	10.0 6.5

## ● MSF~MSFP Type FLANGE TYPE

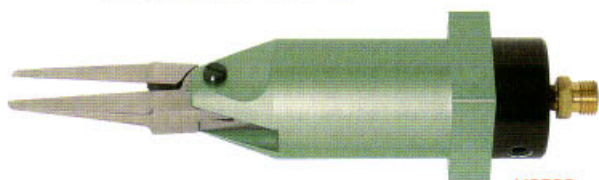

MSF20



MSFP30

### ● MSF (Standard type)

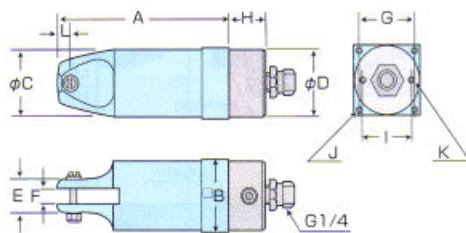

### ● MSFP (Heavy-duty type)

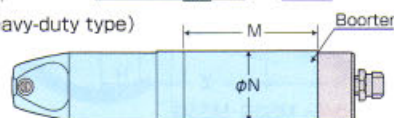

Dimensions

(mm)

Model No.	A	B	C	D	E	F	G	H	I	J	K	L	M	N
MSF10	93	36	35	35	18	9	30	20	24	M3	M4	7	—	—
MSF20	109	45	44	44	24	12	37	20	30	M4	M5	9	—	—
MSF30	150	56	55	55	34	17	46	20	40	M4	M6	15	—	—
MSFP20	109	45	44	44	24	12	37	20	30	M4	M5	9	87	45
MSFP30	150	56	55	55	34	17	46	20	40	M4	M6	15	92	56

Model No.	Length	Grip size	Power (approx.)	Blade No.	Cutting capacity			
					Steel wire	Copper wire	Piano wire	Plastics
MSF10	113 mm	φ 36 mm	580 N	S4, S4S	1.0	1.6	—	—
	180 g	116 cm <sup>3</sup> /Stroke	0.4~0.5 MPa	* Z4, Z4S F3, F3S, FD3	1.0	1.6	0.5	4.0 2.6
MSF20	129 mm	φ 45 mm	1,370 N	S5, S5S, P6, CR6	2.0	2.6	—	—
	310 g	230 cm <sup>3</sup> /Stroke	0.5~0.6 MPa	* Z6, Z6S F5, F5S, FD5	2.0	2.6	1.0	7.0 5.0
MSF30	170 mm	φ 56 mm	2,740 N	S7P, P8P, CR8P	2.8	3.3	—	—
	560 g	584 cm <sup>3</sup> /Stroke	0.5~0.6 MPa	* Z8P F9P, F9PS, FD9P	2.8	3.3	1.2	10.0 6.5
MSFP20	216 mm	φ 45 mm	1,960 N	S5, S5S, P6, CR6	2.0	2.6	—	—
	530 g	400 cm <sup>3</sup> /Stroke	0.4~0.5 MPa	* Z6, Z6S F5, F5S, FD5	2.0	2.6	1.0	7.0 5.0
MSFP30	262 mm	φ 56 mm	4,410 N	S7P, P8P, CR8P	4.0	4.8	—	—
	880 g	956 cm <sup>3</sup> /Stroke	0.5~0.6 MPa	* Z8P F9P, F9PS, FD9P	4.0	4.8	1.2	13.0 6.5



# MACHINE-FITTING TYPE AIR CUTTERS

These cutters can be mounted on machines or robots for automatic cutting operation. Quick response is assured by controlling through a 4-way solenoid valve.

## ● MS~V Type

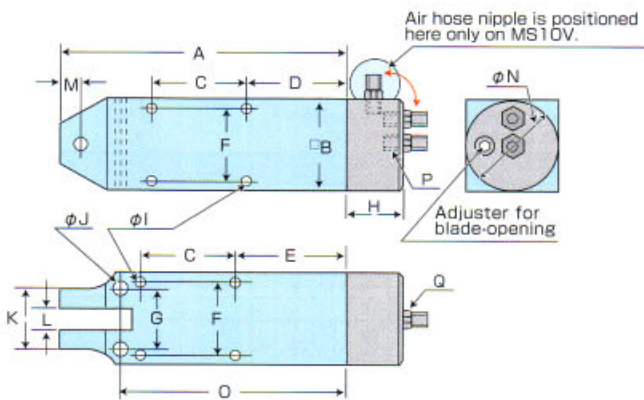
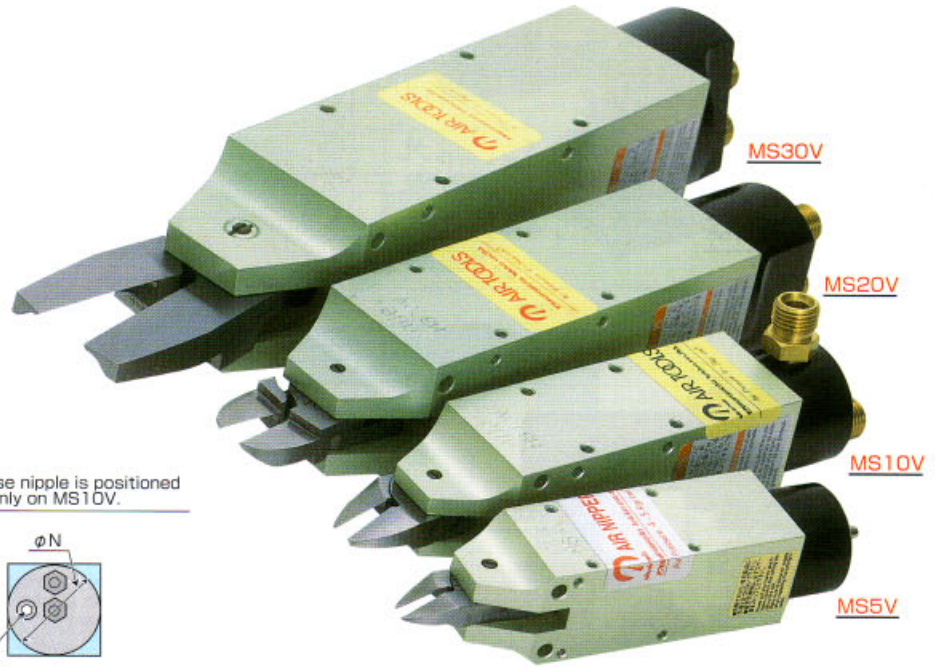

Dimensions

○ All cutting blades for MR-series can be applicable in common.

Model No.	A	B	C	D	E	F	G	H	I	J	K	L	M	N	O	P	Q
MS5V	92	30	30	32	37	24	20	18	M3	4.3	20	7	7	30	72	M5	Nipple M5 × φ4
MS10V	116	36	30	41	46	28	28	23	M4	4.3	20	9	7	36	88	G 1/8	Nipple R 1/8 × G 1/4
MS20V	147	45	40	57	62	36	30	31	M4	5.3	26	12	9	45	119	G 1/8	Nipple R 1/8 × G 1/4
MS30V	185	56	60	55	65	46	40	33	M5	5.3	36	17	15	56	145	G 1/8	Nipple R 1/8 × G 1/4

Model No.	Length Weight	Grip size Air consumption	Power (approx.) Air pressure	Blade No. * Carbide tipped	Cutting capacity φ mm			
					Steel wire	Copper wire	Piano wire	Plastics Soft Hard
MS5V	110 mm	φ 30 mm	390 N	S2, S2S,	0.5	1.0	—	—
	185 g	64 cm <sup>3</sup> /Stroke	0.4~0.5 MPa	* Z2, Z2S	0.5	1.0	0.3	—
				F1, F1S	—	—	—	2.0
MS10V	139 mm	φ 36 mm	580 N	S4, S4S, CR4, EP4	1.0	1.6	—	—
	345 g	116 cm <sup>3</sup> /Stroke	0.4~0.5 MPa	* Z4, Z4S	1.0	1.6	0.5	—
				F3, F3S, FD3	—	—	—	4.0 2.6
MS20V	178 mm	φ 45 mm	1,370 N	S5, S5S, CR6, P6	2.0	2.6	—	—
	650 g	230 cm <sup>3</sup> /Stroke	0.5~0.6 MPa	EP6	1.5	2.0	—	—
				* Z6, Z6S	2.0	2.6	1.0	—
			F5, F5S, FD5	—	—	—	7.0 5.0	
MS30V	218 mm	φ 56 mm	2,740 N	S7P, P8P, CR8P, EP10P	2.8	3.3	—	—
	1,150g	584 cm <sup>3</sup> /Stroke	0.5~0.6 MPa	* Z8P, ZCR8P	2.8	3.3	1.2	—
				F9P, F9PS, FD9P	—	—	—	10.0 6.5



# SETTING TYPE AIR CUTTERS

By installing these power cutters to your machineries, an automatic and continuous cutting can be achieved.

- YMR, SMR, TMR, Type (Standard)
- YMP, SMP, TMP, Type (Heavy-duty)

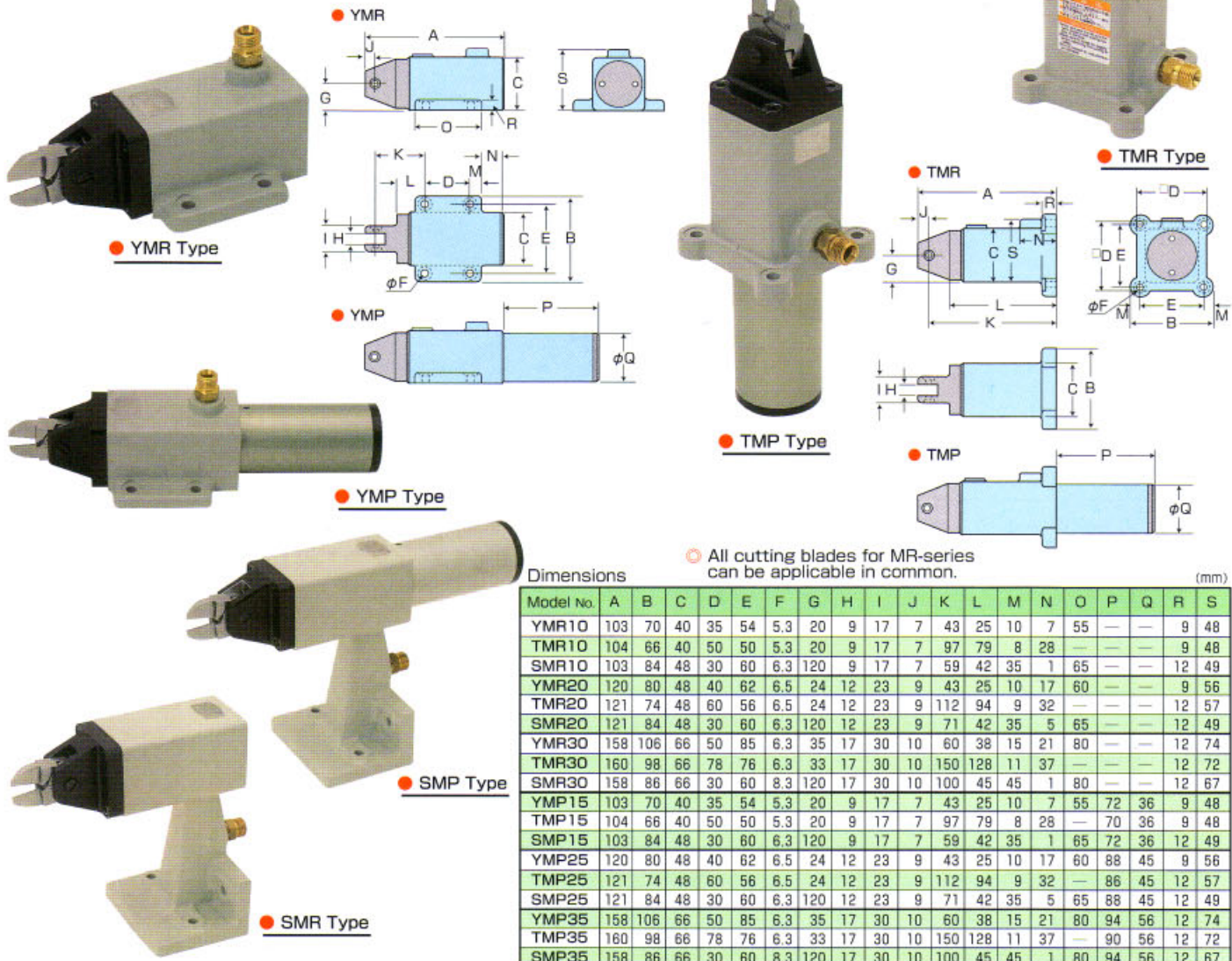

○ All cutting blades for MR-series can be applicable in common.

Dimensions

Model No.	A	B	C	D	E	F	G	H	I	J	K	L	M	N	O	P	Q	R	S
YMR10	103	70	40	35	54	5.3	20	9	17	7	43	25	10	7	55	—	—	9	48
TMR10	104	66	40	50	50	5.3	20	9	17	7	97	79	8	28	—	—	—	9	48
SMR10	103	84	48	30	60	6.3	120	9	17	7	59	42	35	1	65	—	—	12	49
YMR20	120	80	48	40	62	6.5	24	12	23	9	43	25	10	17	60	—	—	9	56
TMR20	121	74	48	60	56	6.5	24	12	23	9	112	94	9	32	—	—	—	12	57
SMR20	121	84	48	30	60	6.3	120	12	23	9	71	42	35	5	65	—	—	12	49
YMR30	158	106	66	50	85	6.3	35	17	30	10	60	38	15	21	80	—	—	12	74
TMR30	160	98	66	78	76	6.3	33	17	30	10	150	128	11	37	—	—	—	12	72
SMR30	158	86	66	30	60	8.3	120	17	30	10	100	45	45	1	80	—	—	12	67
YMP15	103	70	40	35	54	5.3	20	9	17	7	43	25	10	7	55	72	36	9	48
TMP15	104	66	40	50	50	5.3	20	9	17	7	97	79	8	28	—	70	36	9	48
SMP15	103	84	48	30	60	6.3	120	9	17	7	59	42	35	1	65	72	36	12	49
YMP25	120	80	48	40	62	6.5	24	12	23	9	43	25	10	17	60	88	45	9	56
TMP25	121	74	48	60	56	6.5	24	12	23	9	112	94	9	32	—	86	45	12	57
SMP25	121	84	48	30	60	6.3	120	12	23	9	71	42	35	5	65	88	45	12	49
YMP35	158	106	66	50	85	6.3	35	17	30	10	60	38	15	21	80	94	56	12	74
TMP35	160	98	66	78	76	6.3	33	17	30	10	150	128	11	37	—	90	56	12	72
SMP35	158	86	66	30	60	8.3	120	17	30	10	100	45	45	1	80	94	56	12	67

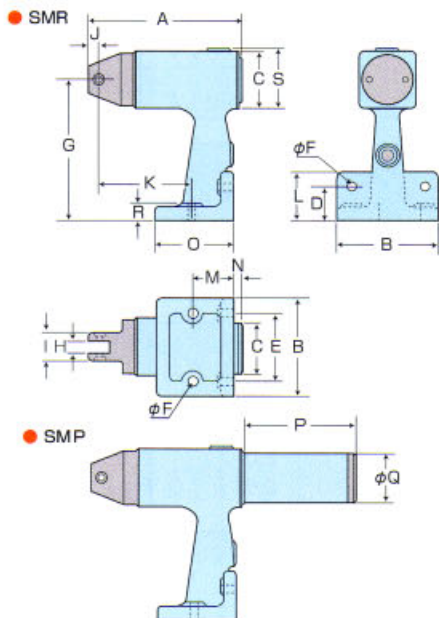

Model No.	Weight	Air consumption	Air pressure	Power (approx.)	Blade No. ● Carbide tipped	Cutting capacity $\phi$ mm			
						Steel wire	Copper wire	Piano wire	Plastics Soft Hard
YMR10	310g	116 cm <sup>3</sup> /Stroke	0.4~0.5 MPa	580 N	S4, EP4	1.0	1.6	—	—
TMR10	320g				* Z4	1.0	1.6	0.5	—
SMR10	770g				CR4	1.0	1.6	—	—
YMR20	470g	230 cm <sup>3</sup> /Stroke	0.5~0.6 MPa	1,370 N	F3, FD3, F3S	—	—	—	4.0 2.6
TMR20	490g				S5, P6, EP6	2.0	2.6	—	—
SMR20	770g				* Z6	2.0	2.6	1.0	—
YMR30	1,240g	584 cm <sup>3</sup> /Stroke	0.5~0.6 MPa	2,740 N	F5, FD5, F5S	—	—	—	7.0 5.0
TMR30	1,260g				S7P, P8P, EP10P	2.8	3.3	—	—
SMR30	1,620g				* Z8P, ZCR8P	2.8	3.3	1.2	—
YMP15	420g	170 cm <sup>3</sup> /Stroke	0.3~0.35 MPa	735 N	CR8P	2.8	3.3	—	—
TMP15	430g				F9P, FD9P, F9PS	—	—	—	10.0 6.5
SMP15	880g				S4, EP4	1.0	1.6	—	—
YMP25	640g	400 cm <sup>3</sup> /Stroke	0.4~0.5 MPa	1,960 N	* Z4	1.0	1.6	0.5	—
TMP25	660g				CR4	1.0	1.6	—	—
SMP25	940g				F3, FD3, F3S	—	—	—	4.0 2.6
YMP35	1,560g	956 cm <sup>3</sup> /Stroke	0.5~0.6 MPa	4,410 N	S5, P6, EP6	2.0	2.6	—	—
TMP35	1,580g				* Z6	2.0	2.6	1.0	—
SMP35	1,940g				CR6	2.0	2.6	—	—
YMP35	1,560g	956 cm <sup>3</sup> /Stroke	0.5~0.6 MPa	4,410 N	F5, FD5, F5S	—	—	—	7.0 5.0
TMP35	1,580g				S7P, P8P, EP10P	4.0	4.8	—	—
SMP35	1,940g				* Z8P, ZCR8P	4.0	4.8	1.2	—
					CR8P	4.0	4.8	—	—
					F9P, FD9P, F9PS	—	—	—	13.0 6.5



# HIGH POWER AIR CUTTERS

- ◆ Power output is amplified by employing a square piston.
- ◆ No spring for piston re-setting is used for less trouble.

## ● ZE Type

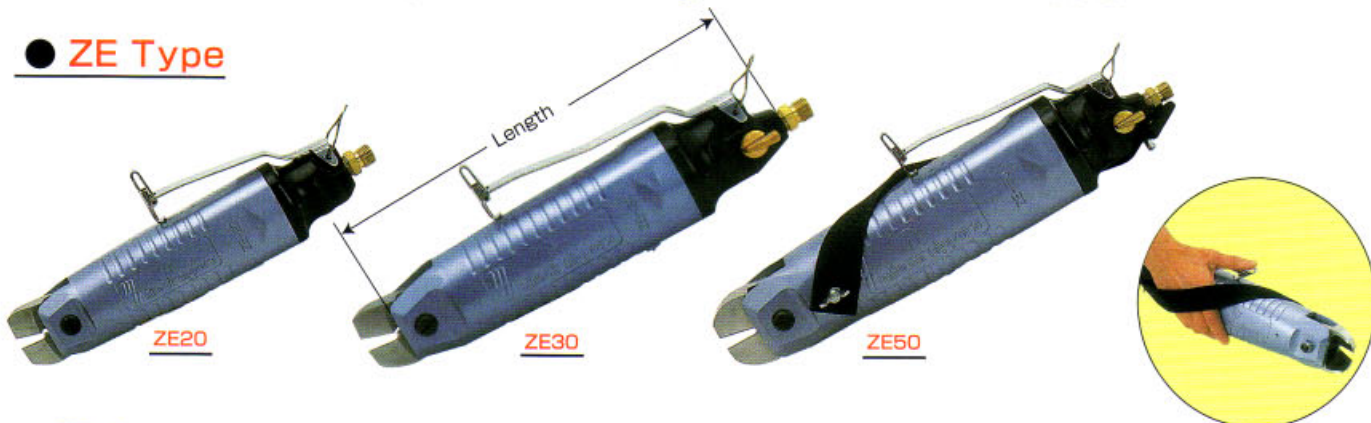

With various different blades equipped, these high power cutters offer versatile uses for calking, punching holes, bending and others in addition to general applications for cutting steel wires, stainless wires, plastics and crimping terminals, etc.

Supporting belt is available only for ZE50

Model No.	Length	Blade No.	Cutting Capacity							Dimensions	
			4) Steel wire	Copper wire	Stainless wire	Plano wire	Crimping	Plastic Soft	Plastic Hard	$\phi$ mm	
ZE 20	Length	203 mm	P55	2.8	3.3	2.3	—	—	—	—	a=35 b=19 c=5.5 d=— g=— f'=35°
	Weight	580 g	CR55	2.8	3.3	2.3	—	—	—	—	a=35 b=14 c=5.5 d=8 g=— f'=—
	Grip size	□ 50 mm	* Z55	2.8	3.3	2.3	1.2	—	—	—	a=35 b=16 c=5.5 d=— g=— f'=35°
	Air consumption	480 cm <sup>3</sup> /stroke	* ZCR55	2.8	3.3	2.3	1.2	—	—	—	a=35 b=14 c=5.5 d=8 g=— f'=—
	3) Power (approx.)	2,700 N	A55-1.25	—	—	—	—	1) 1.25	—	—	a=31 b=— c=— d=6 g=12 f'=—
	Air pressure	0.6 MPa	AR55-1.25	—	—	—	—	2) 1.25	—	—	a=31 b=— c=— d=6 g=2 f'=—
ZE 30	Length	238 mm	P85	4.0	4.8	2.8	—	—	—	—	a=38 b=22 c=7.0 d=— g=— f'=35°
	Weight	803 g	CR85	4.0	4.8	2.8	—	—	—	—	a=38 b=17 c=7.0 d=8 g=— f'=—
	Grip size	□ 56 mm	* Z85	4.0	4.8	2.8	1.2	—	—	—	a=38 b=20 c=7.0 d=— g=— f'=35°
	Air consumption	1,100 cm <sup>3</sup> /stroke	* ZCR85	4.0	4.8	2.8	1.2	—	—	—	a=38 b=17 c=7.0 d=8 g=— f'=—
	3) Power (approx.)	4,200 N	F95	—	—	—	—	—	10.0	6.0	a=66 b=38 c=12.5 d=— g=— f'=15°
	Air pressure	0.6 MPa	FD95	—	—	—	—	—	9.0	6.5	a=60 b=30 c=11.5 d=— d=— f'=30°
			A85-1.25	—	—	—	—	1) 1.25	—	—	a=32 b=— c=— d=6 g=13 f'=—
			A85-2.0	—	—	—	—	1) 2.0	—	—	a=31 b=— c=— d=6 g=12 f'=—
			A85-5.5	—	—	—	—	1) 5.5	—	—	a=33 b=— c=— d=6 g=14 f'=—
			AR85-1.25	—	—	—	—	2) 1.25	—	—	a=32 b=— c=— d=6 g=12.5 f'=—
			AR85-2.0	—	—	—	—	2) 2.0	—	—	a=33 b=— c=— d=6 g=14 f'=—
		AR85-5.5	—	—	—	—	2) 5.5	—	—	a=35 b=— c=— d=6 g=16 f'=—	
ZE 50	Length	307 mm	P125	5.0	6.0	4.0	—	—	—	—	a=48 b=27 c=8.0 d=— g=— f'=25°
	Weight	2,000 g	CR125	5.0	6.0	4.0	—	—	—	—	a=50 b=23 c=8.0 d=10 g=— f'=—
	Grip size	□ 70 mm	A125-5.5	—	—	—	—	1) 5.5	—	—	a=43 b=— c=— d=7 g=18 f'=—
	Air consumption	1,850 cm <sup>3</sup> /stroke	A125-8.0	—	—	—	—	1) 8.0	—	—	a=43 b=— c=— d=7 g=19 f'=—
	3) Power (approx.)	7,350 N	AR125-5.5	—	—	—	—	2) 5.5	—	—	a=43 b=— c=— d=7 g=18 f'=—
	Air pressure	0.6 MPa	AR125-8.0	—	—	—	—	2) 8.0	—	—	a=46 b=— c=— d=7 g=21 f'=—

## SHAPE OF BLADE

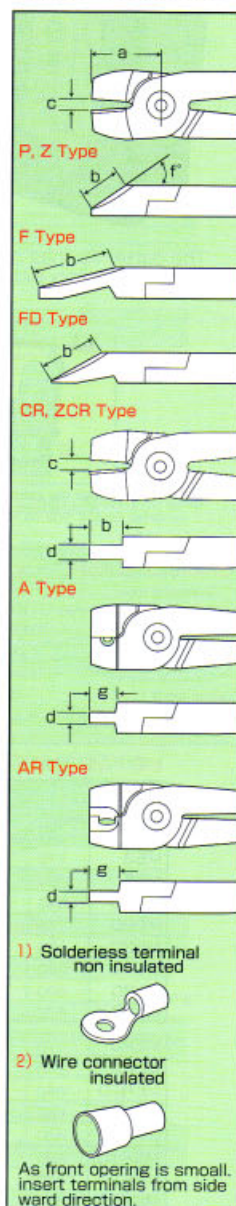

- 3) "POWER" signifies the force that works around the center of P-type blade with air pressure of 0.6MPa (6kgf/cm<sup>2</sup>).
- 4) Most easy to cut soft steel wires. The capacity should be lower proportionally against hardened steel wires.



# "SLIDE & CUT" TYPE AIR CUTTERS

## ME Type

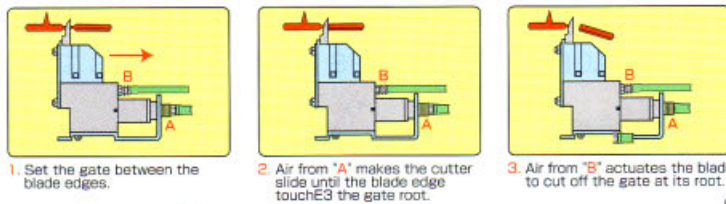
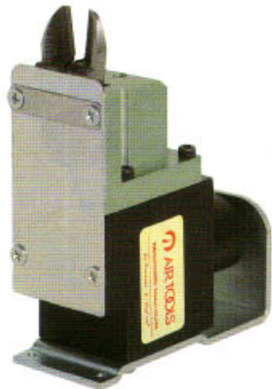

## MER Type



The cutter inclines on the fulcrum without vibratory side swing.

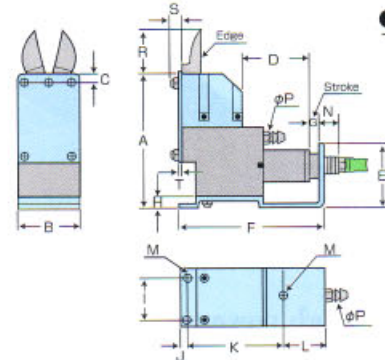

## ML Type

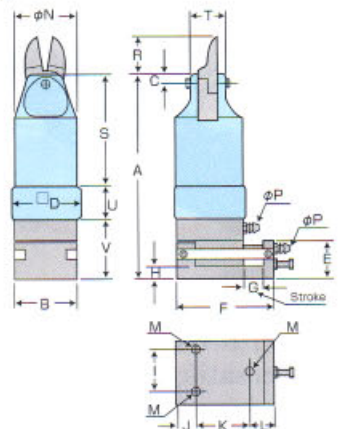

The cutter unit slides in parallel with the mounting stand without vibratory side swing.

## MSR Type

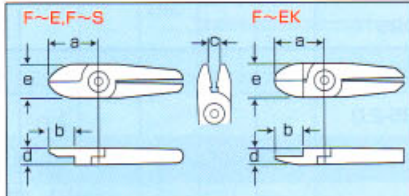
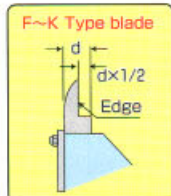
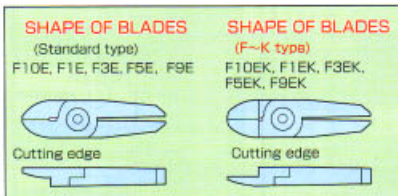
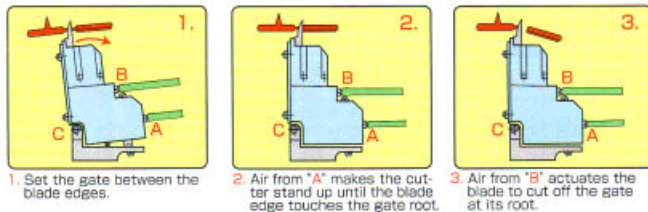
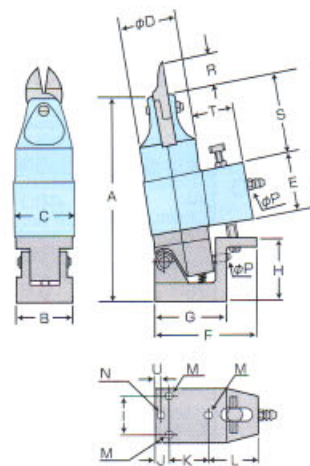
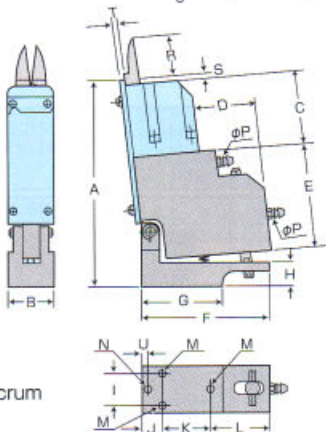

Blade No.	a	b	c	d	e
F10E, F10EK	24	13	3.5	7	12
F1E, F1EK	24	12	5.5	7	15
F3E, F3EK	27	13	7.0	9	20
F5E, F5EK	35	18	9.0	12	23
F9E, F9EK	65	39	15.0	17	35
F3S	27	13	4.5	9	20
F5S	35	16	8.5	12	23
F9PS	65	37	15.0	17	35

## ME / ML / MER / MSR Type

Dimensions

(mm)

Model No.	Weight g	Air consumption cm <sup>3</sup> /Stroke	Air pressure MPa	Blade No.		Cutting capacity Plastics	Dimensions																			
							A	B	C	D	E	F	G	H	I	J	K	L	M	N	P	R	S	T	U	V
ME3	170	30	0.4~0.5	F10E	F10EK	1.0	74.2	20	8	33	34.2	71.2	3	6.2	14	2.5	50	18.7	M3	12.1	4.0	21	3.3	2	—	—
ME5	290	40	0.4~0.5	F1E	F1EK	1.2	75.2	29	9	30	31.2	77.2	3	6.2	22	5	50	22.2	M3	12.1	4.0	21	4.0	2	—	—
ME10	540	90	0.4~0.5	F3E	F3EK	2.5	97.2	35	10	39	42.2	88.2	3	6.2	26	5	50	33.2	M3	13.0	4.0	21	4.0	2	—	—
ME20	810	150	0.5~0.6	F5E	F5EK	4.5	111.2	44	13	42	48.2	103.2	5	6.2	34	5	85	13.2	M4	13.0	4.0	27	2.3	2	—	—
ME30	1,490	300	0.5~0.6	F9E	F9EK	6.0	149.2	56	15	51	84.2	127.2	5	6.2	40	7	85	35.2	M4	14.0	4.0	50	3.3	3	—	—
ML10	340	136	0.4~0.5	F3S	—	4.0	128	35	7	36	31	63	10	8	26	11	31	21	M3	35.0	4.0	19	71	18	16	41
ML20	500	250	0.5~0.6	F5S	—	7.0	143	44	9	45	31	64	10	8	26	11	36	17	M4	44.0	4.0	26	79	24	23	41
ML30	870	634	0.5~0.6	F9PS	—	10.0	184	55	15	56	33	76	10	8	26	14	38	24	M4	55.0	4.0	50	123	34	18	43
MER3	170	30	0.4~0.5	F10E	F10EK	1.0	83	20	28	26	41	54	34	10	14	8.5	20.5	25	M3/D8	M3	4.0	13	3	2	2.5	—
MER5	260	40	0.4~0.5	F1E	F1EK	1.2	90	29	28	25	42	62	42	10	22	8.5	28.5	25	M3/D8	M3	4.0	15	4	2	2.5	—
MER10	440	90	0.4~0.5	F3E	F3EK	2.5	116	35	35	32	57	73	51	12	26	9	36	28	M3/D10	M3	4.0	16	5	2	3.0	—
MER20	680	150	0.5~0.6	F5E	F5EK	4.5	123	44	42	33	60	84	62	12	26	10	46	28	M4/D10	M4	4.0	23	8	2	3.0	—
MER30	1,400	300	0.5~0.6	F9E	F9EK	6.0	160	56	47	41	71	109	70	16	28	11	50	48	M4	M4	4.0	50	25	3	4.0	—
MSR10	380	136	0.4~0.5	F3S	—	4.0	130	35	36	35	35	63	44	40	26	9	31	23	M3/D10	M3	4.0	19	52	27	3.0	—
MSR20	520	250	0.5~0.6	F5S	—	7.0	145	44	45	44	35	71	51	40	28	10	36	25	M4/D10	M4	4.0	26	67	26.5	3.0	—
MSR30	1,400	634	0.5~0.6	F9PS	—	10.0	192	55	56	55	40	91	85	47	26	11	38	42	M4	M4	4.0	50	101	35	4.0	—



# VERTICAL-TYPE AIR CUTTERS

Fixed models without sliding / inclining action

(Same blades for ME-series are used in common.)

● MF Type

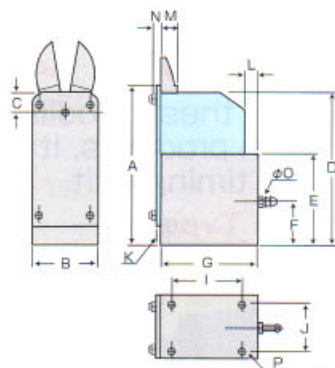
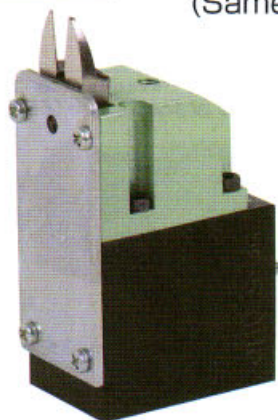

Dimensions (mm)

Model No.	Weight	Air Pressure	Air consumption	Blade No.	Cutting capacity Plastics	Dimensions														
						A	B	C	D	E	F	G	I	J	K	L	M	N	O	P
MF3	71g	0.4~0.5 MPa	30 cm <sup>3</sup> /Stroke	F10E F10EK	1.0	71	20	8	68	40	10	38	25	14	2	10	7	3.3	4	M4/D10
MF5	73g	0.4~0.5 MPa	40 cm <sup>3</sup> /Stroke	F1E F1EK	1.2	73	29	9	69	41	20	44	30	22	2	7	7	4.0	4	M4/D10
MF10	96g	0.4~0.5 MPa	90 cm <sup>3</sup> /Stroke	F3E F3EK	2.5	96	35	10	91	56	20	53	40	26	2	8	9	4.0	4	M4/D15
MF20	110g	0.5~0.6 MPa	150 cm <sup>3</sup> /Stroke	F5E F5EK	4.5	110	44	13	102	60	20	64	45	34	2	13	12	3.0	4	M4/D15

## GATE CUTTING TABLE

Mount required number of the ME-type cutters on this table in adequately for simultaneous cutting of multiple pieces of plastic gates.

EXAMPLE OF AN ASSEMBLY UNIT  
Individually designed and assembled by us to fit the sample work pieces supplied from customers.

### SETTING TABLE

Model	T 3 × 4
A × B	400×300
Weight	9 kg
Model	MAX arrang emenh
ME3	20 set
ME5	20 set
ME10	16 set
ME20	14 set
ME30	10 set

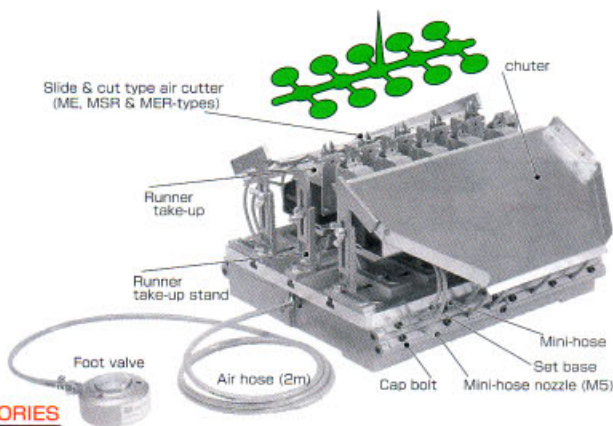
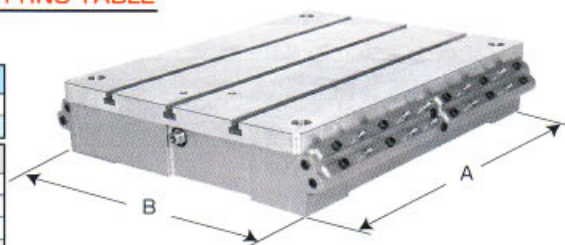

### STANDARD ACCESSORIES

- Chuter 1set
- Runner Take-ups 1set
- Foot valve (FB70S) 1set
- Air hose (UH2) 1pc
- Timing unit (TU01) built-in

### OPTIONAL ACCESSORIES

- Slide & cut type air cutter (ME, MER, MSR-types)
- Set base
- Mini hose
- Mini-hose nozzles.

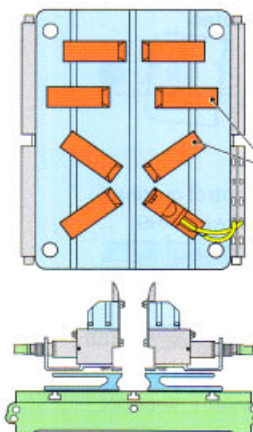

Air cutters  
Air cutters can be set freely in any configuration.

### SET BASES

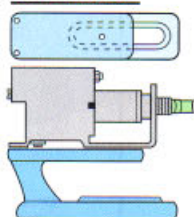

Set each air cutter to the set base and align each unit on the setting table.

### EXAMPLE OF SETTING

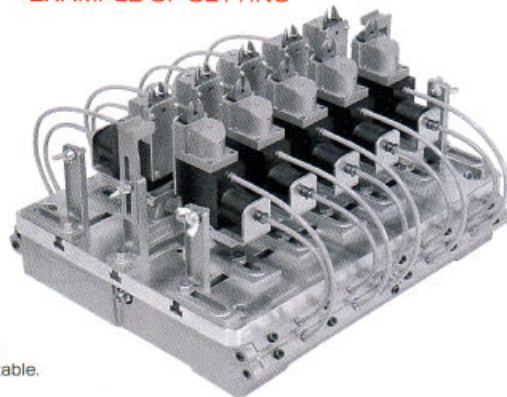

## HOW TO USE THE TIMING UNIT

### TU01

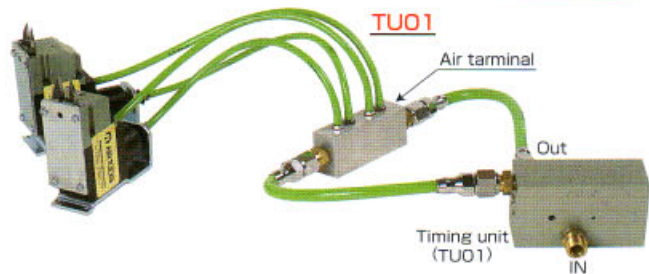

- The timing unit is controlled by solenoid valve and timer.
- Using the timing unit (option).

Air from the IN-valve firstly flows through "A" branch, and secondly through "B" branch after a short interval.

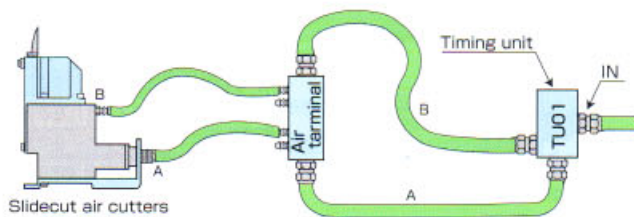



# GATE CUTTING AIR CUTTERS

USE these models for cutting mold resin products. It is unnecessary to use timing unit.

## ● MG Type

Compact size and Light in Weight.

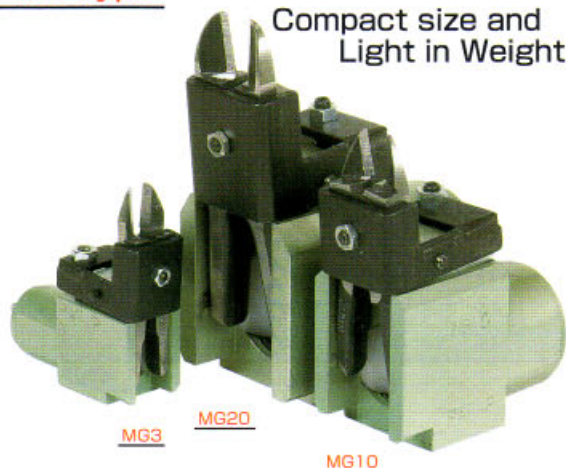

MG3

MG20

MG10

Model No.	Air Pressure	Air consumption	Weight	Blade No.	Cutting capacity-Plastics
MG3	0.4~0.5 MPa	22 cm <sup>3</sup> /Stroke	80 g	FG10 FG10K	2.0 mm
MG10	0.4~0.5 MPa	60 cm <sup>3</sup> /Stroke	230 g	FG3 FG3K	4.0 mm
MG20	0.5~0.6 MPa	90 cm <sup>3</sup> /Stroke	420 g	FG5 FG5K	6.0 mm

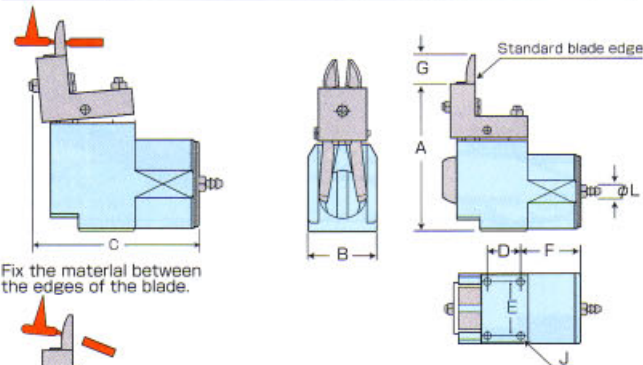

Fix the material between the edges of the blade.

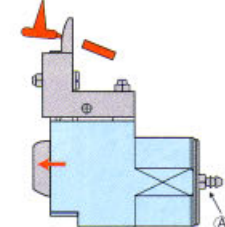

Air from (A) pushes the tool body forward to allow the blade cut the material at its root.

Dimensions (mm)

Model No.	A	B	C	D	E	F	G	J	L
MG3	50	20	60	16	14	25	15.0	M3	4
MG10	73	35	73	20	27	29	17.5	M3	4
MG20	95	46	89	21	36	39	19.0	M4	4

## ● FG Type

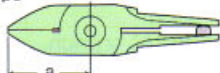

## ● FG~K Type

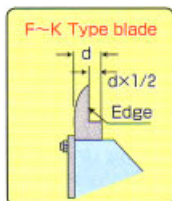
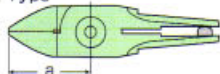

(mm)

Blade No.	a	c	d
FG10	24	4.0	7.0
FG10K	24	4.0	7.0
FG3	27	7.0	9.0
FG3K	27	7.0	9.0
FG5	34	8.0	12.0
FG5K	34	8.0	12.0

# MACHINE-FITTING TYPE AIR HEAT-CUTTERS

Cutting blades are heated for easy cutting. Suitable especially for such a hard plastic as acrylic resin.

## ● AH Type

● Operate through solenoid valve or foot-valve (FB70S).



AH5

Cutting speed can be adjusted through Air Regulator.

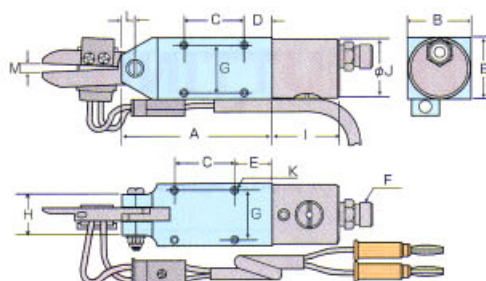

Dimensions (mm)

Model No.	Weight	Air consumption	A	B	C	D	E	F	G	H	I	J	K	L	M
AH5	210g	64/min	75.5	32	30	14	19	G1/4	26	21	34	31	M3 Ø7	7	4
AH8	290g	116/min	94	36	30	18	23	G1/4	28	23	36	35	M4 Ø8.5	8	6

## Standard blades

FA5 (for AH5)

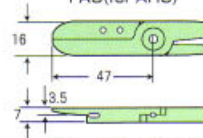

Effective length of blade: about 15 mm  
Cutting capacity: φ3 mm (hard plastic)

FAB (for AH8)

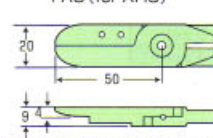

Effective length of blade: about 15 mm  
Cutting capacity: φ4 mm (hard plastic)

## Optional blades for cutting plate gates.



Stopper

(Blade has a stopper for even or depth-control cutting.)

FA5A (for AH5)

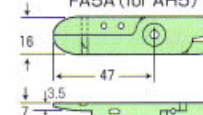

Effective length of blade: about 12mm  
Cutting capacity:  
1.0mm (thickness) x 70mm (width)

FABA (for AH8)

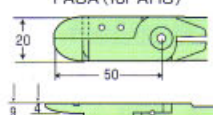

Effective length of blade: about 12mm  
Cutting capacity:  
1.0mm (thickness) x 10mm (width)

## ● TRANSFORMER

This transformer must be used for operation of these heat-nippers.



- Model NO. HTR30N ( 100 V, 220 V or 240 V )
- Input power ( AC 100 V, AC220 V or AC240 V )
- Output power 30 VA (MAX)
- Length of cord 1.5m

## ● HEATER No. W-19





# MACHINE-FITTING TYPE SLIDING AIR CUTTERS

Install to the robot arms for automatic cutting jobs

## ● CF Type

Firstly the blade integrated in the holder extends by 30mm from the body front face. Then the blade functions to cut.

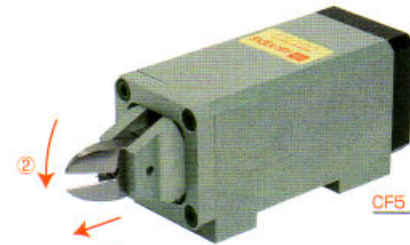

- Extend out by 30mm.
- Blade functions to cut.

### CF type

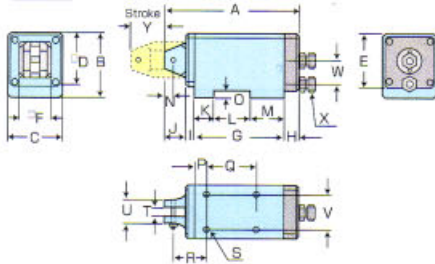

## ● CL Type

Firstly the blade functions to cut. Then the blade with holder slides back into the body.



- Blade functions to cut.
- Slide back by 30mm.

### CL type

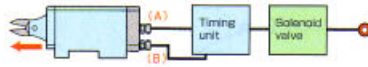
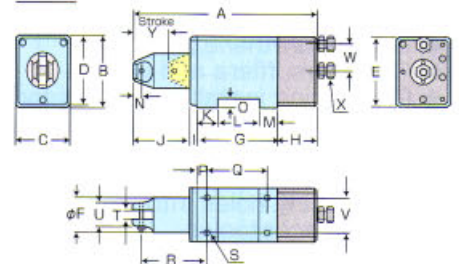

Adjust the timing lag of blade tow-step for the most suitable cutting performance.



Use a timer to adjust the tow-step timing lag

- Use 3-way type solenoid valve or foot valve.
- Use our timing unit (model; TU-D1) or a timer to adjust the timing lag between ① and ② actions.
- The body can turn by 90° for suitable positioning.

Dimensions

Model No.	Weight g	Air Consumption cm <sup>3</sup> /Stroke	Air pressure MPa	Blade No.	Cutting capacity		Dimensions (mm)																			Blades for MR-type can be used in common.						
					Steel Wire 0.5	Plastics 2.0	A	B	C	D	E	F	G	H	I	J	K	L	M	N	O	P	Q	R	S		T	U	V	W	X	Y
CF5	570	490	0.4~0.5	S2S F1S	0.5	2.0	124	54	44	44	47	28	80	15	10	19	16	33	31	7	8	10	45	32	M6/D12	7	20	30	18		MR5	
CF10	940	830	0.4~0.5	S4S F3S	1.0	4.0	146	64	54	54	54	34	100	15	10	21	26	40	34	7	8	16	60	40	M6/D12	9	20	30	19	G1/4	30	MR10
CF20	1,300	1,160	0.5~0.6	S5S F5S	2.0	7.0	165	70	62	62	62	42	117	15	10	23	28	55	36	9	8	16	75	40	M6/D10	12	26	34	21		MR20	
CL5	650	300	0.4~0.5	S2S F1S	0.5	2.0	165	60	44	58	58	30	73	35	7	50	18	37	18	7	8	9	55	59	M6/D10	7	20	30	23		MR5	
CL10	1,050	590	0.4~0.5	S4S F3S	1.0	4.0	187	70	54	70	70	36	88	35	7	57	23	40	25	7	8.5	15	58	72	M6/D12	9	20	34	28.5	G1/4	30	MR10
CL20	1,450	980	0.5~0.6	S5S F5S	2.0	7.0	205	80	62	80	80	42	104	30	8	63	28	50	26	9	10	18	70	80	M6/D12	12	26	40	32.5		MR20	

# AIR SQUEEZERS

Applications are ; riveting, caulking, punching, clipping, etc.

## ● GXT Type

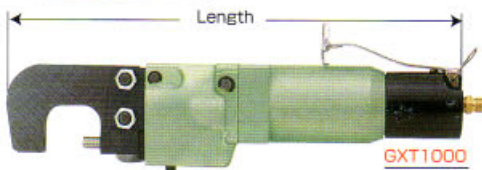

GXT1000

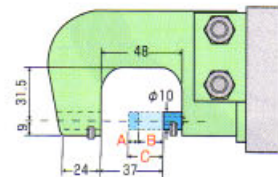

- A = 3.5mm (pressure power generation zone)
- B = 17mm (quick projection zone)
- C = 20.5mm (overall stroke)

★ Attachments are optional and manufactured on demand.  
★ Use a suitable die for punching.

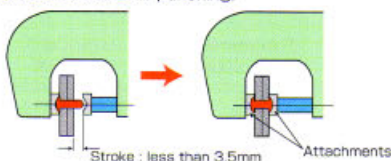

## ● GXY Type

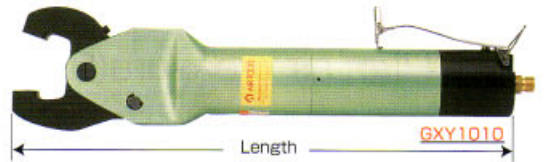

GXY1010

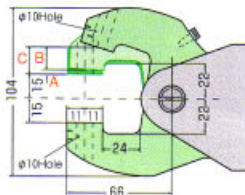

- A = 3mm (pressure power generation zone)
- B = 14mm (quick projection zone)
- C = 17mm (overall stroke)

★ Other attachments can be designed and offered to meet each particular application.

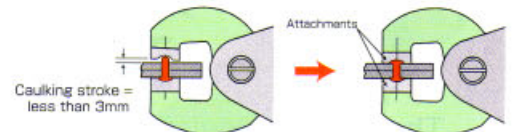

Model No.	Length	Weight	Grip size	Air consumption	Power (approx.) Air pressure	Capacity (for reference)	
						Riveting	Punching holes
GXT1000	378 mm	3,300g	φ 65 mm	700 cm <sup>3</sup> /stroke	5,780 N 0.5~0.6 MPa	Steel rivet = less than φ 2 mm Aluminum rivet = less than φ 4 mm	φ 4 mm Holes (2 mm Steel Plate)
	490 mm	3,900g	φ 56 mm	1,200 cm <sup>3</sup> /stroke	6,800 N 0.5~0.6 MPa	Steel rivet = less than φ 2 mm Aluminum rivet = less than φ 5 mm	φ 4 mm Holes (3 mm Steel Plate)
GXY1010	425 mm	3,200g	φ 56 mm	1,100 cm <sup>3</sup> /stroke	6,860 N 0.5~0.6 MPa	Steel rivet = less than φ 2 mm Aluminum rivet = less than φ 5 mm	
	540 mm	4,300g	φ 56 mm	1,600 cm <sup>3</sup> /stroke	10,780 N 0.5~0.6 MPa	Steel rivet = less than φ 3 mm Aluminum rivet = less than φ 8 mm	

★ Pressure power generated on the quick projection zone (average) = 80kg (impossible to punch holes in such a hard material as stainless steel.)



# AIR FIL-SAWS

Light in weight and silent in operation.

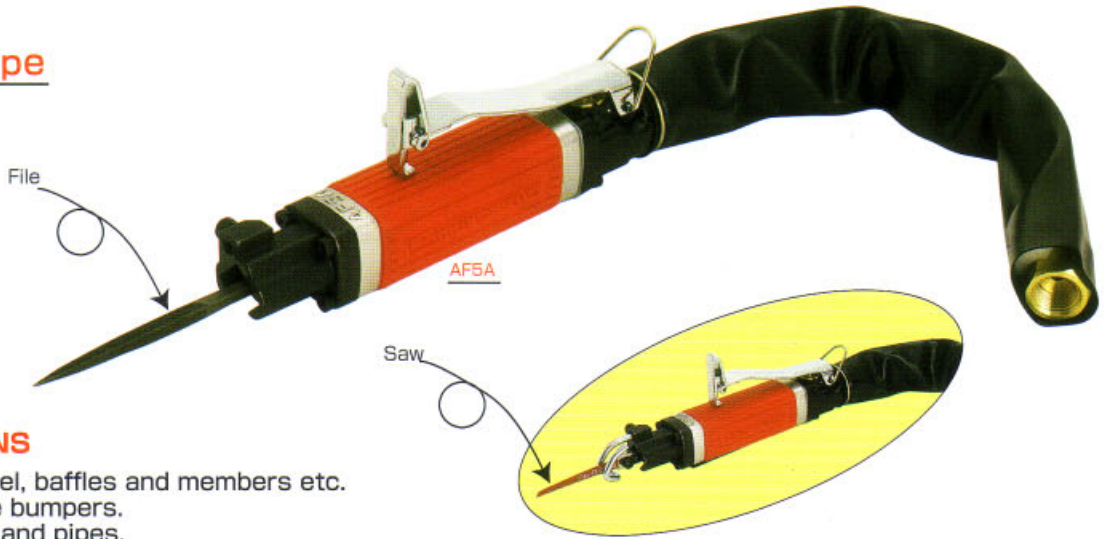

## ● AF Type







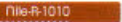

## ● APPLICATIONS

- ◆ Cutting auto-panel, baffles and members etc.
- ◆ Cutting urethane bumpers.
- ◆ Cutting mufflers and pipes.
- ◆ Processing installation holes for bumpers, fog lamps, speakers etc.
- ◆ Cutting holes in steel plates and finishing.
- ◆ Finishing wooden or plastic products.
- ◆ Processing holes into plaster board for power receptacles.
- ◆ Finishing dies.
- ◆ Chamfering parts after machining.
- ◆ Processing round holes to be square holes.
- ◆ Deburring die-castings.

### SAW BLADE ( OPTION )

No.	Application	Teeth/ inch	Shape
SR1036	Steel ( Small circle )	36	 File-SR-1036
R1010	Urethane	10	 File-R-1010
W1014	Wood Aluminium	14	 File-W-1014

Recommended air pressure 0.65MPa

Model No.	Length	Weight	Grip size	Stroke	Reciprocating speed strokes/min	Air consumption	Cutting capacity (iron plate) mm / min (approx.)	Teeth/ inch	Standard saw blade No. & Shape	Files No. & Shape
AF5A	158 mm	380 g	29×29 mm	5 mm	3,500 /min	200 ℓ/min	1 mm Plate 500	36	R0536  File-R0536	AFR50 Flat 
AF7	190 mm	650 g	39×37 mm	7 mm	6,900 l/min	280 ℓ/min	1 mm Plate 900 3 mm Plate 135	32	AF1032  File-AF-1032	AFR50 Round 
AF7S				5 mm	8,400 /min		1 mm Plate 850 3 mm Plate 135		R1032  File-R-1032	AFT50 Triangular 
AF10S				10 mm	5,500 /min		1 mm Plate 1,000 3 mm Plate 180			

# FILE SAW

High air pressure(0.55~0.9MPa) allowable type

## ● PWS12 Type

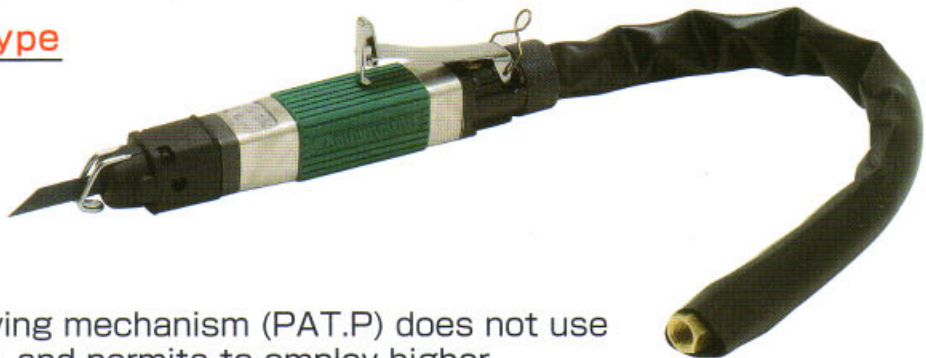

The unique driving mechanism (PAT.P) does not use cushion spring and permits to employ higher air pressure for powerful operation.

Model No.	Length	Weight	Grip size	Stroke	Reciprocating speed strokes/min	Air consumption	Cutting capacity (iron plate) mm / min (approx.)	Standard saw blades	Standard Files
PWS12	730 mm	1,100 g	38×38 mm	12 mm	5,500 /min	200 ℓ/min	1 mm Plate: 900 3.4 mm Plate: 100	Same as AF10S	Same as AF10S



# AIR PLATE SHEARS

Can be used to cut thin metal plate, rubber plate, resin plate, carpet, etc .....

## ● PSH Type



PSH05 Mini plate shears  
Standard blade, E250S

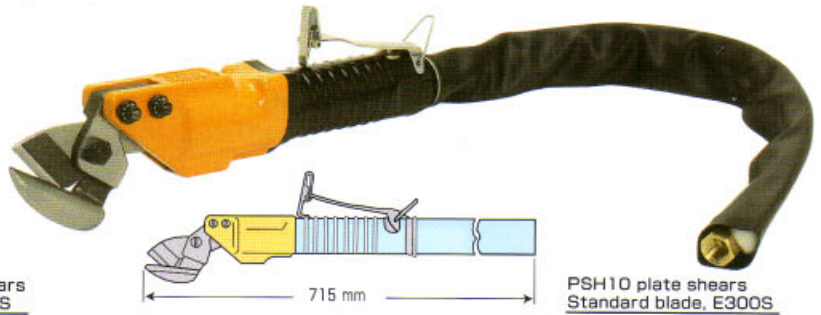

PSH10 plate shears  
Standard blade, E300S

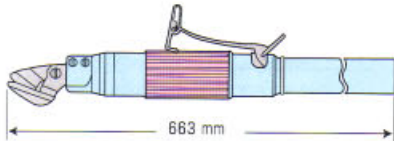

Optional blade



Standard blade



Carbide tipped

Model No.	Length Weight	Grip size	Cutting speed	Air consumption		Blade No.	Max Cutting capacity
				Q/min	Air pressure		
PSH05	191mm	φ 40 mm	1,220 / min	300	0.55~0.65 MPa	E250S <Standard>	Metal Plate: 0.6mm
	700g			E250 <Optional>		Aluminium Plate: 0.8mm	
PSH10	225mm	φ 40 mm	1,900 / min	450	0.55~0.65 MPa	E300S <Standard>	Metal Plate: 1.2mm
	1,230g			E300 <Optional>		Aluminium Plate: 1.2mm <W/E300S>	
				E300H <High-speed steel made>		Resin Plate: 2.5mm <W/E300>	
				E300Z <Carbide tipped>		Rubber/Risin Plate: 3.0mm <W/E300>	

"Max. Cutting Capacity" is not definite but just a rough guidance for tool choice.

# AIR MULTI-PURPOSE SCISSORS

Versatile to cut a wide variety of materials, such as light sheet metal, plastics and carpet, etc.

## ● GS01 Type



12,000 cuts per minute.



Blade No. 10M

Model No.	Length	Weight	Grip size	Air consumption	Air pressure
GS01	140mm	500g	φ36mm	450 Q/min	0.35~0.6 MPa

Suitable for cutting or trimming thin metal sheet vinyl cloth, paper, etc.

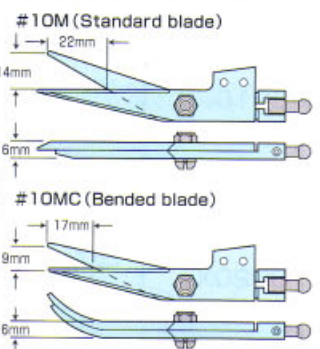

# AIR CORD BUSER

Quick and secure Insertion of cord bushes is performed.

## ● BN19 Type



Examples of applications



Several blades are available to fit various sizes of bushes.

Model No.	Length	Weight	Body size	Air consumption	Air pressure	Capacity
BN19	164mm	500g	φ45mm	160 cm <sup>3</sup> /Stroke	0.5~0.6 MPa	Bushes for holes of φ9.5mm~15.9mm

# AIR TWISTER

Wires are twisted much faster than manual operation.

## ● RC6 Type

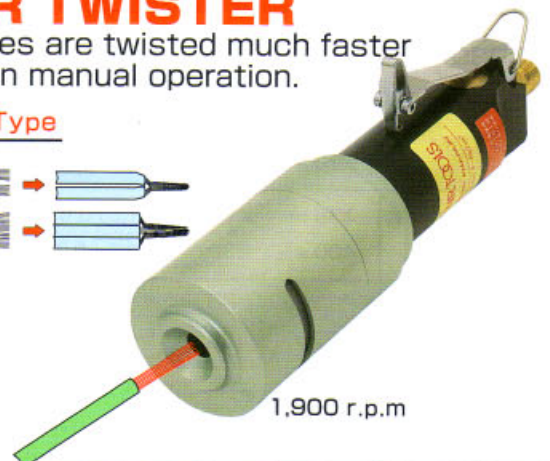
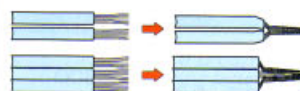

1,900 r.p.m

Model No.	Length	Weight	Body size	Air consumption	Air pressure
RC6	180mm	830g	φ38mm	0.45 cm <sup>3</sup> /Stroke	0.5~0.6 MPa



# AIR CUTTERS

## (SET A SIDE-EDGED GOING)

### ● CP Type (standard)



CP20

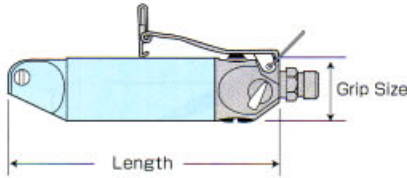

### ● CP~X Type (Heavy-duty)



CP20X

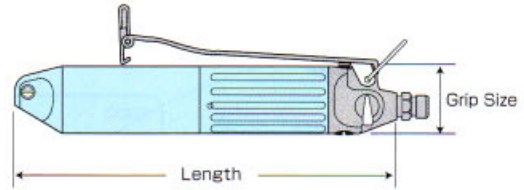

## MACHIN-FITTING TYPE AIR CUTTERS

### Set a Side-Edged Going

### ● CP~M Type (Standard)



CP20M

### ● CP~XM Type (Heavy-duty)



CP30XM

### ● SHAPE OF BLADE

S, F, Z Type

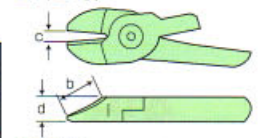

FD Type



CR Type

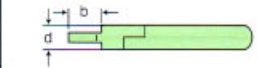

EP Type

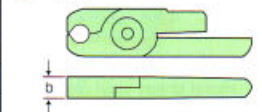

Y Type

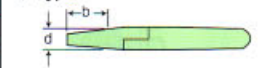

Model No.	Length Weight	Grip size Air consump- -tion	Power (approx.) Air pressure	Blade No. * Carbide tipped	Cutting capacity $\phi$ mm				
					Steel wire	Copper wire	Piano wire	Plastics Soft	Hard
CP10	132 mm	$\phi$ 36 mm	580 N	S400, EP400, CR400	1.0	1.6	—	—	—
	220 g	116 cm <sup>2</sup> /Stroke	0.4~0.5 MPa	* Z400, F300, FD300	1.0	1.6	0.5	—	—
CP20	170 mm	$\phi$ 45 mm	1,370 N	P600, EP600, S500, CR600	2.0	2.6	—	—	—
	400 g	230 cm <sup>2</sup> /Stroke	0.5~0.6 MPa	* Z600 F500, FD500	2.0	2.6	1.0	—	—
CP20X	257 mm	$\phi$ 45 mm	1,960 N	P600, EP600, S500, CR600	2.0	2.6	—	—	—
	600 g	400 cm <sup>2</sup> /Stroke	0.4~0.5 MPa	* Z600 F500, FD500	2.0	2.6	1.0	—	—
CP30	201 mm	$\phi$ 56 mm	2,740 N	P800, EP100, CR800	2.8	3.3	—	—	—
	630 g	584 cm <sup>2</sup> /Stroke	0.5~0.6 MPa	* Z800 F900, FD900	2.8	3.3	1.2	—	—
CP30X	293 mm	$\phi$ 56 mm	4,410 N	P800, EP100, CR800	3.8	4.5	—	—	—
	940 g	956 cm <sup>2</sup> /Stroke	0.5~0.6 MPa	* Z800 F900, FD900	3.8	4.5	1.2	—	—
CP10M	113 mm	$\phi$ 36 mm	580 N	S400, EP400, CR400	1.0	1.6	—	—	—
	220 g	116 cm <sup>2</sup> /Stroke	0.4~0.5 MPa	* Z400 F300, FD300	1.0	1.6	0.5	—	—
CP20M	136 mm	$\phi$ 45 mm	1,370 N	P600, EP600, S500, CR600	2.0	2.6	—	—	—
	400 g	230 cm <sup>2</sup> /Stroke	0.5~0.6 MPa	* Z600 F500, FD500	2.0	2.6	1.0	—	—
CP20XM	223 mm	$\phi$ 45 mm	1,960 N	P600, EP600, S500, CR600	2.0	2.6	—	—	—
	600 g	400 cm <sup>2</sup> /Stroke	0.4~0.5 MPa	* Z600 F500, FD500	2.0	2.6	1.0	—	—
CP30M	167 mm	$\phi$ 56 mm	2,740 N	P800, EP100, CR800	2.8	3.3	—	—	—
	630 g	584 cm <sup>2</sup> /Stroke	0.5~0.6 MPa	* Z800 F900, FD900	2.8	3.3	1.2	—	—
CP30XM	259 mm	$\phi$ 56 mm	4,410 N	P800, EP100, CR800	3.8	4.5	—	—	—
	940 g	956 cm <sup>2</sup> /Stroke	0.5~0.6 MPa	* Z800 F900, FD900	3.8	4.5	1.2	—	—

(mm)

Blade No.	b	c	d
S400	15	3.0	9
Z400	11	3.0	9
F300	15	3.0	9
FD300	15	3.0	9
P600	15	5.0	12
EP600	12	5.0	12
CR600	18	7.0	12
Z600	17	5.0	12
F500	22	7.0	12
FD500	20	7.0	12
P800	20	6.0	17
EP100	17	6.0	17
CR800	22	7.0	17
Z800	20	5.0	17
F900	45	10.0	17
FD900	27	10.0	17



# AIR SHEARS

Suitable to cut slim metal plates, plastic plates, wire nets, etc.

- AS Type (Standard)
- ASP Type (Heavy-duty)



AS100(Standard)



ASP150(Heavy-duty)

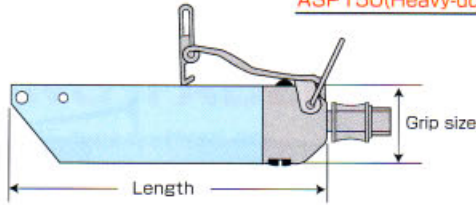
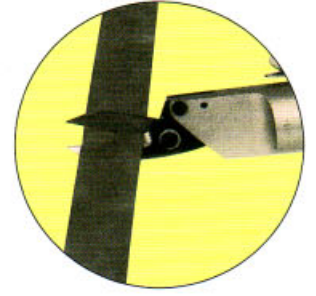

Model No.	Length Weight	Grip size Air consumption	Air pressure	Blade No.	Cutting capacity Plata $\phi$ mm
AS100	139 mm 230 g	$\phi$ 36 mm 116 cm <sup>3</sup> /Stroke	0.5~0.6 MPa	No.100S, No.100R, No.110R	0.5 x 15
AS200	166 mm 500 g	$\phi$ 45 mm 230 cm <sup>3</sup> /Stroke	0.5~0.6 MPa	No.200S, No.200R, No.210R	0.8 x 25 1.0 x 10
ASP150	211 mm 300 g	$\phi$ 36 mm 223 cm <sup>3</sup> /Stroke	0.5~0.6 MPa	No.100S, No.100R, No.110R	0.5 x 20
ASP250	253 mm 720 g	$\phi$ 45 mm 508 cm <sup>3</sup> /Stroke	0.4~0.6 MPa	No.200S, No.200R, No.210R	0.8 x 25 1.0 x 15

## MACHINE-FITTING TYPE AIR SHEARS

- AM Type

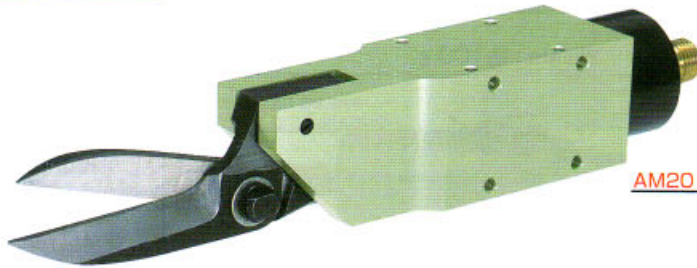

AM20

Dimensions (mm)

Model No.	A	B	C	D	E	F	G	H	I	J	K	L	M
AM10	113	36	20	30	16	21	28	9	10	26	24	M4 D10	M4 D6.5
AM20	139	45	20	40	20	25	36	9	10	26	30	M5 D12	M4 D8

Model No.	Length Weight	Air pressure Air consumption	Blade No.	Cutting capacity Plata $\phi$ mm
AM10	133 mm 296 g	0.5~0.6 MPa 116 cm <sup>3</sup> /Stroke	No.100S, No.100R, No.110R	0.5 x 15
AM20	159 mm 507 g	0.5~0.6 MPa 230 cm <sup>3</sup> /Stroke	No.200S, No.200R, No.210R	0.8 x 25 1.0 x 10

### ● SHAPE OF BLADES

- No.100S, No.200S

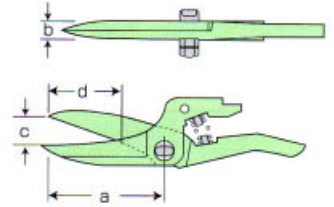

- No.100R, No.200R

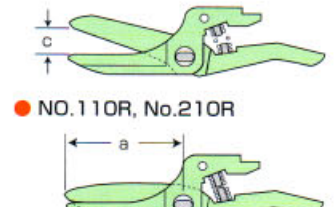

- NO.110R, No.210R

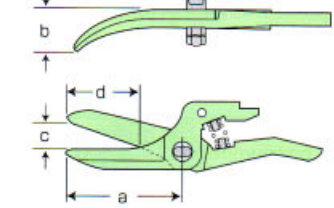

Blade No.	a	b	c	d
No.100S	66	10	15	37
No.200S	66	10	15	37
No.100R	62	10	14	34
No.200R	62	10	14	34
No.110R	60	17	15	25
No.210R	60	17	15	25

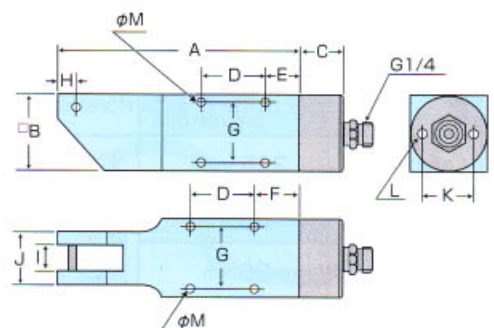



# AIR SHOT-HAMMER

These shot-hammers simplify and quicken various inserting jobs of pins, bushings, collar caps, oil seals, bearings, etc. in assembly lines.

## ● RH, CB Type

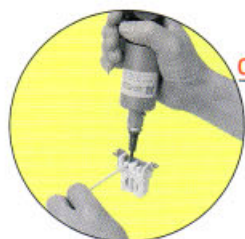

CB13S

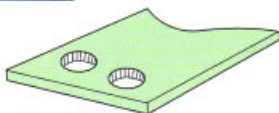

Punching a hole on a rubber sheet.

RVS85

Standard rivet snap.

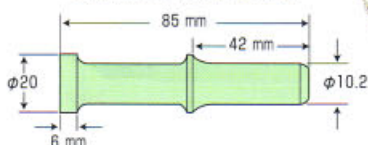

Air pressure 0.5~0.7MPa

Grip size	φ 37 mm	<b>RH20</b>		Remarks  <b>Single blow</b> ( Each operation of the lever generates one blow )
Air consumption	220 cm <sup>3</sup> /stroke		Overall length : 213 mm Weight : 900 g	
Blowing power	(Approx.) 2.25 N-m			
Grip size	φ 45 mm	<b>RH80</b>		
Air consumption	650 cm <sup>3</sup> /stroke		Overall length : 254 mm Weight : 1,300 g	
Blowing power	(Approx.) 3.13 N-m			
Grip size	φ 43 mm	<b>RH90</b>		Remarks  <b>Single blow</b> ( Heavy duty type )  It can be used for stamping, riveting and chipping, by changing the attachments.
Air consumption	1,200 cm <sup>3</sup> /stroke		Overall length : 328 mm Weight : 1,600 g	
Blowing power	(Approx.) 5.88 N-m			
Grip size	φ 43 mm	<b>RH100Z</b> ( Heavy-duty )		
Tank size	φ 72 mm		Overall length : 330 mm Weight : 2,100 g	
Blowing power	(Approx.) 8.82 N-m			
Grip size	φ 51 mm	<b>RH200</b> ( Heavy-duty )		Remarks  <b>Small sized type</b> ( Each operation of the lever generates one blow )
Tank size	φ 86 mm		Overall length : 341 mm Weight : 2,100 g	
Air consumption	2,500 cm <sup>3</sup> /stroke			
Blowing power	(Approx.) 12.74 N-m			
Length	175 mm	<b>CB13S</b> ( Small-size )		
Weight	310 g			
Grip size	φ 30 mm			
Air consumption	54 cm <sup>3</sup> /stroke			
Length	215 mm	<b>CB13L</b>		
Weight	500 g			
Grip size	φ 36 mm			
Air consumption	64 cm <sup>3</sup> /stroke			

Air pressure 0.5~0.6MPa



# CABLE STRIPPERS

With one-touch operation, these cable strippers can strip power source cables, VA cables and multi-core cables.

## ● CST Type

Length	260 mm
Weight	8.0 kg
Height	100 mm
Width	150 mm
Air consumption	850 cm <sup>3</sup> /stroke
Air pressure	0.5~0.6 MPa
Stripping capacity	up to $\phi$ 5 mm outer dia.
Stripping length	30 mm

### CST30



Length	420 mm
Weight	13.5 kg
Height	169 mm
Width	318 mm
Air consumption	3,000 cm <sup>3</sup> /stroke
Air pressure	0.5~0.6 MPa
Stripping capacity	up to $\phi$ 15 mm outer dia.
Stripping length	100 mm

### CST100

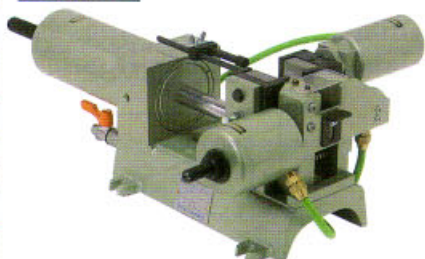

The most popular model and can strip wires in complicated ways.

Length	470 mm
Weight	21 kg
Height	200 mm
Width	275 mm
Air consumption	3,100 cm <sup>3</sup> /stroke
Air pressure	0.5~0.6 MPa
Stripping capacity	up to $\phi$ 15 mm outer dia.
Stripping length	100 mm

### CST110

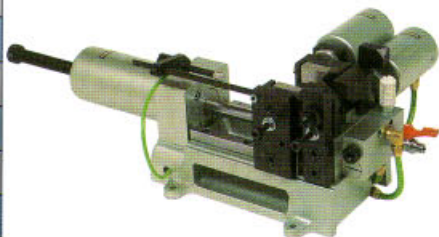

Length	785 mm
Weight	18 kg
Height	155 mm
Width	300 mm
Air consumption	5,872 cm <sup>3</sup> /stroke
Air pressure	0.5~0.6 MPa
Stripping capacity	up to $\phi$ 15 mm outer dia.
Stripping length	200 mm

### CST100L

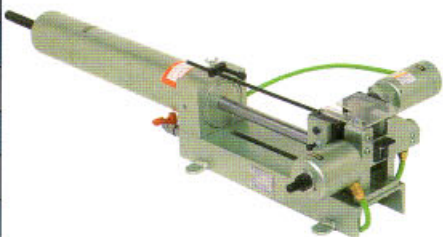

Stripping capacity is 200 mm in length

Length	490 mm
Weight	43 kg
Height	283 mm
Width	490 mm
Air consumption	8,000 cm <sup>3</sup> /stroke
Air pressure	0.5~0.6 MPa
Stripping capacity	up to $\phi$ 30 mm outer dia.
Stripping length	100 mm

### CST120



Heavy-duty

A combination of several blades enables stripping of various cables in complicated way through only one or two steps of operation as below illustrated.

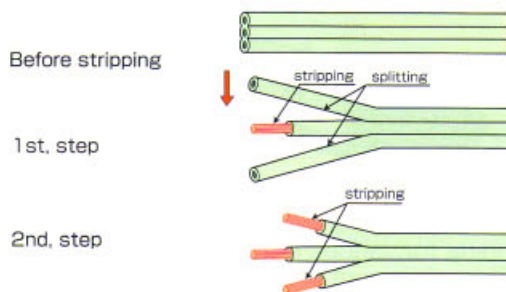

#### Easy operation.

1. Fix the cable to blades.
2. Push the foot valve.
3. The cable is instantly stripped.

#### Easy change of blades.

1. Loosen the blade setting screws.
2. Mount the blades and fasten the screws.

A variety of optional blades is available to fit different cables.

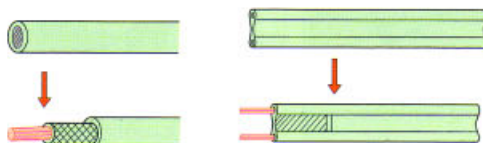

#### Examples of application.

By one or two operations.

#### Simple stripping



Split joined cables and strip them at the same time.

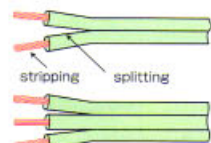

Strip inner and outer coatings at the same time.

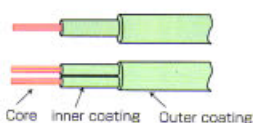

Split the joined cables and strip at different positions at the same time.

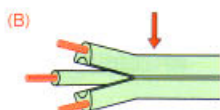
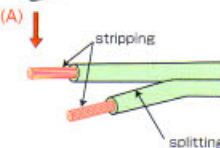
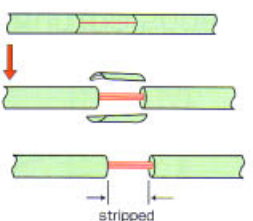
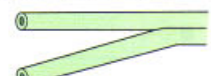

Cut cable coatings intermediately. Then take the cut coatings with hand pliers to strip out cables.



# MINI BELTER AIR BELT SANDERS

## ● MB20 (non-lever) Type



## ● MB25 (lever) Type



### APPLICATIONS

- ◆ Sanding for various auto-repair services such as...
  - Removing spot welding.
  - Removing paint off flat or curved surfaces.
  - Removing adhesives.
  - Removing welding bead.
- ◆ Finishing wood work.
- ◆ Deburring small metal products.
- ◆ General finishing work.
- ◆ Removing rust.
- ◆ Other sanding and polishing work.

3-point belt suspension makes sanding more smooth (MB20S, MB25, MB25S)

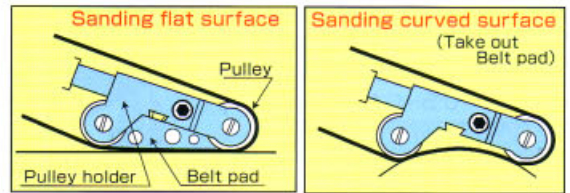

Removing adhesives.



Removing paint and other coating in concave places.

Model No.	Length	Weight	Air consumption	Air pressure	Free belt speed	Belt size	Remarks
MB20	250mm	930g	300 l/min	0.5~0.6 MPa	2,200 m/min	20mm x 500mm	Diameter of pulley $\phi$ 21mm
MB20S		1,180g					Diameter of pulley $\phi$ 21mm
MB25	300mm	1,310g				20mm x 520mm	Diameter of pulley $\phi$ 21mm
MB25S		1,180g				10mm x 520mm	Diameter of pulley $\phi$ 12mm

## WIRE TWISTER

When the lever is pressed, the blade catches the wire and rotates to twist it.

### ● WT06 / SP40W Type

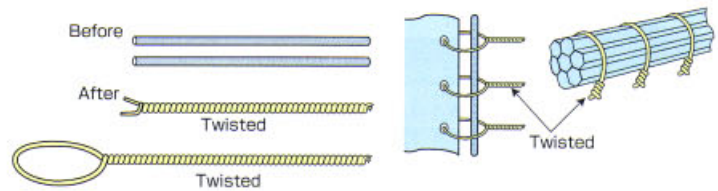

Model No.	Length	Weight	Body size	Air consumption	Air pressure	Twisting capacity
WT06	225mm	800g	$\phi$ 38mm	450 l/min	0.55~0.6 MPa	Steel wire $\phi$ 1.0mm
						Copper wire $\phi$ 1.2mm
SP40W	245mm	1,200g				Steel wire $\phi$ 1.2mm
						Copper wire $\phi$ 2.0mm

## CUTTING BENDER

For simultaneous cutting and bending wire end of electronic components.

### ● CB13 Type

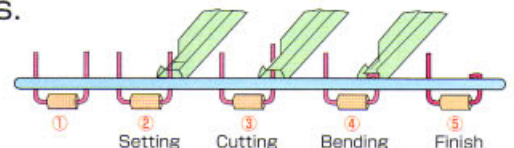

Model No.	Length	Weight	Body size	Air consumption	Air pressure	Capacity
CB13	185mm	330g	$\phi$ 36mm	64 cm <sup>3</sup> /Stroke	0.4~0.6 MPa	Copper $\phi$ 1.2mm



# STAND-HOLDER FOR MACHINE-INSTALLATION

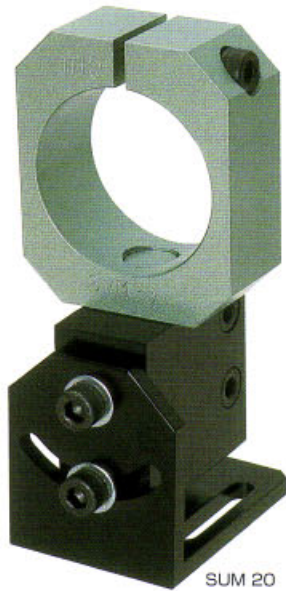

SVM 20

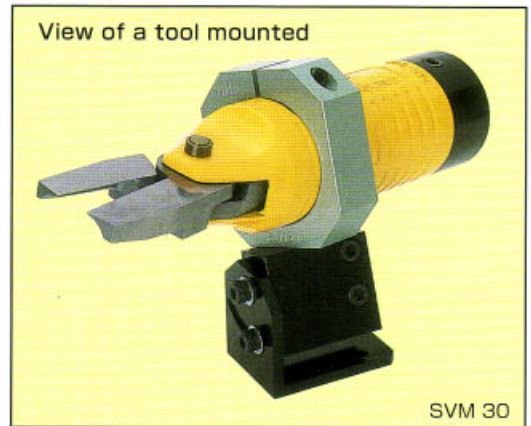

View of a tool mounted

SVM 30

## 《 UNIVERSAL POSITIONING 》

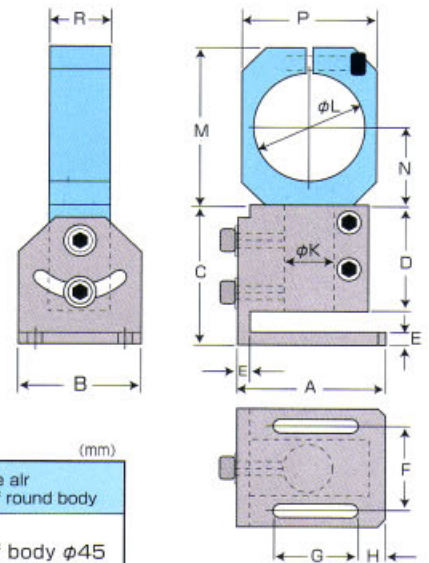
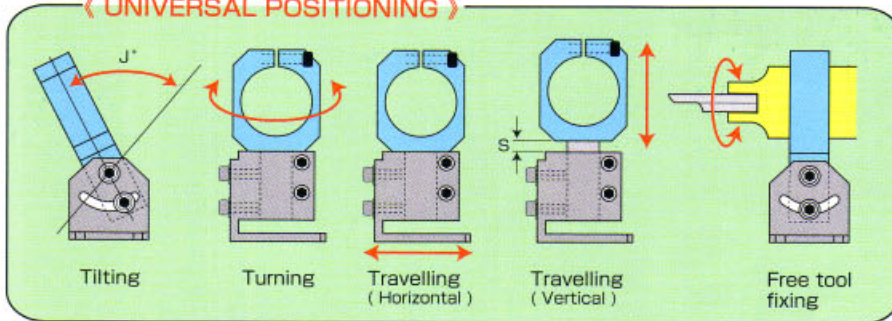

Dimensions

(mm)

Model No.	Weight	A	B	C	D	E	F	G	H	J (MAX)	K	L	M	N	P	R	S (MAX)	Applicable air cutters of round body
SVM 20	325g	60	50	59	45	5	36	34	11	90°	20	45.1	67	33	55	24	15	MR20M series of body $\phi 45$
SVM 30	367g	60	50	59	45	5	36	34	11	90°	20	56.1	78	38	70	24	15	MR30AM series of body $\phi 56$

## FOOT VALVE

### 3-Port Foot Valve

● **FB70S**

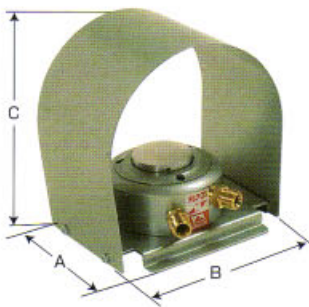

### 4-Port Foot Valve

● **FV80**

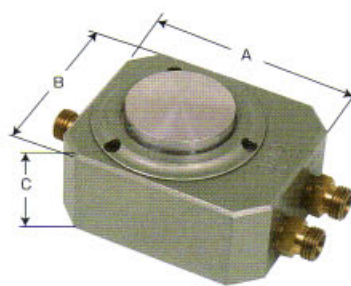

## FIXING STAND

《For MR20, MR30A & MP35A》

● **Fixing stand**

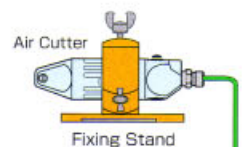
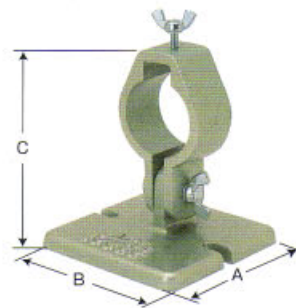

Dimensions

Model No.	Weight	A	B	C	Applicable tools
FB70S	970 g	110 mm	122 mm	145 mm	
FV80	600 g	83 mm	69 mm	48 mm	
FIXING STAND	600 g	140 mm	120 mm	118 mm	For MR20, MR20M
FIXING STAND	500 g	140 mm	120 mm	118 mm	For MR30A, MP30AM