

TOSHIBA MACHINE

COMPO ARM  
ARM ROBOT

**BA-II**  *SERIES*



# COMPO ARM

## BA-II

The BA series widely used among users for diversified applications have been replaced by the new BA-II series which are now on the worldwide market. Ample variations covering from a single axis to orthogonal axes (2 to 4 axes) are lined up to respond to each user's requirements.

The operating procedures and outer dimensions (\*) of the BA-II series are compatible with those of the previous series and functions are upgraded.

(\* Excluding BB05 and BB07)

### ● Short cycle time

<Maximum speed>

- Driven by ball screw: 1,200 mm/s (Previous series: 1,000 mm/s), stroke 600 mm or less
- Driven by timing belt: 2,000 mm/s

### ● High accuracy

<Positioning repeatability>

- Driven by ball screw:  $\pm 0.01$  mm (Previous series:  $\pm 0.02$  mm)
- Driven by timing belt:  $\pm 0.05$  mm

### ● Absolute specifications for all types

Absolute encoders not requiring home position return are used in all types.

- To back up the encoder, long life lithium battery is used. The battery life is about 50,000 hours (previous series: 8,000 hours).

A backup lithium battery is equipped on the controller (master unit, slave unit) as standard.

### ● Use of high-speed CPU

The controller has high-level processing ability through the use of a high-speed CPU.

### ● Ample variations

The actuator (or axis) comes in the following types; nine ball screw types and seven timing belt types.

The motor set position can be selected from one of the four directions for each axis.

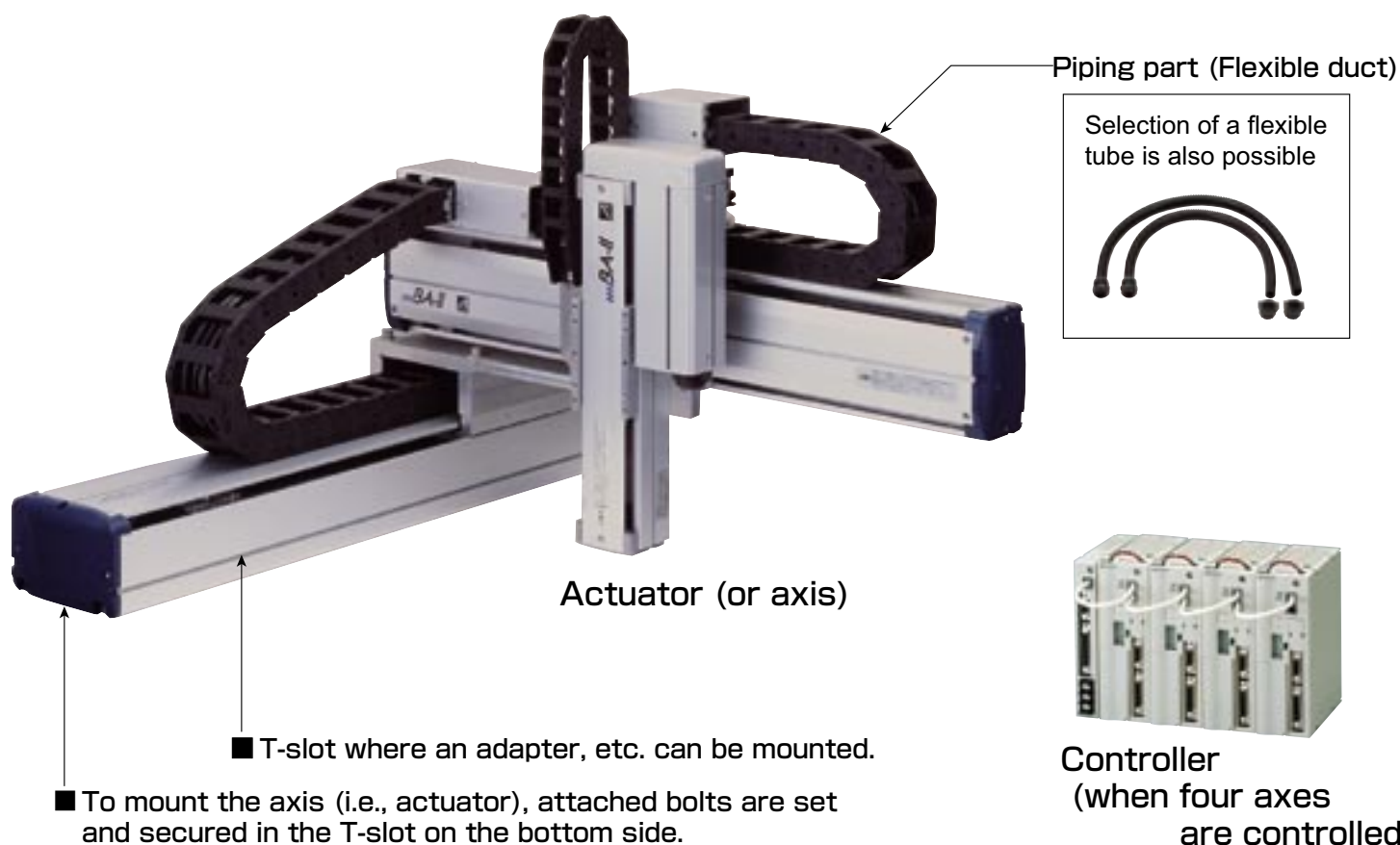

## 【Features of actuator】

- ◎ Absolute encoders are equipped on all types as standard.  
No home return operation is required. Just after the power is turned on or emergency stop is effected, a program can be executed from a given point.
- ◎ Minimized space for installation  
As four types of motor set positions are available for each axis, you can choose a desired set position according to your installation space, thus saving the space.
- ◎ Attaching importance to basic performance  
Miniature AC servo motors and highly rigid linear guides are employed for all types.

## 【Features of controller】

- ◎ Compact size  
Can be neatly housed in the panel and sized similar to miniature AC servo motor driver.
- ◎ Use of ROIbot arm language noted for easy teaching.
- ◎ Standard controllers for all types  
A high-performance master unit is used for all types.  
A master unit and slave unit can be used for axes of all 50, 100 and 200W types.

### Master unit

- ◎ Designed for multi-power supply voltages  
Master power voltage coping with globalized production.  
(AC100 V – 120 V, 200 V – 240 V)
- ◎ Pulse train input mode  
A pulse train input port is equipped as standard to execute a real-time operation. (Master unit only)
- ◎ Multitask function  
The multitask function which allows simultaneous execution of multiple jobs is equipped as standard.

### High-performance master unit

- ◎ CP control  
Two-dimensional and three-dimensional linear interpolation, circular interpolation and pass functions are available as standard.
- ◎ Axis travel via RS232C  
Real-time axis motion via RS232C communication, which is optimized for image processing job.
- ◎ General-purpose output of specified coordinate  
General-purpose output control (ON and OFF) during axis motion is possible, which is optimized for sealing and painting jobs.
- ◎ Supporting CC-Link  
Interface with an external equipment can be realized by using CC-Link. Thus, wire-saving and high-speed data communication are possible.

## Set designation intended for easy selection of a desired type

All necessary actuator, controller, etc., are put together and treated as the set throughout this manual.

Set designation BA2-A5-A3AR-404530-0F23

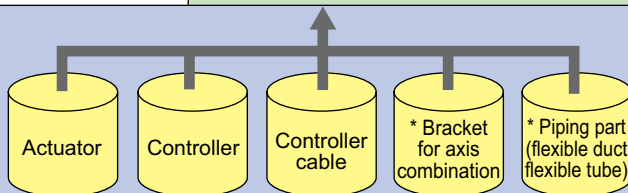

\* Only for orthogonal axes

Thus, you need not bother about which type is the best for your requirements.

We can address any combination other than the standard combinations introduced in this manual.

You can also purchase a single unit as before by referring to relevant pages of respective units.

# CONTENTS

ROIbot Lineup	2
Type Selection	5
Single Axis Specifications	6
2-Axis Combination	8
3-Axis Combination	10
4-Axis Combination	12
Example applications	13
Before you read this manual	14
Terms used in the manual	15
Selection of single axis specifications	16
Single Axis Specifications	19
Ball Screw Driven	20
Timing Belt Driven	34
R-Axis (Rotation)	46
Orthogonal Axes Specifications	49
2-Axis Specifications X-Y Combination	50
X-Z Combination	79
Y-Z Combination	97
Z-Y Combination	115
3-Axis Specifications X-Y-Z Combination	131
4-Axis Specifications X-Y-Z-R Combination	163
Variations	171
Simple Dust-Resistant Axes Specifications	172
Cleanroom Axis Specifications	174
Axis-Related Components	177
Axis Combination Bracket	178
Parts for Control System	197
Controller Unit, Options	198
Technical Notes	219
Actuator, Controller	220
How to Calculate Tact (Cycle) Time	242

## RObot Lineup

### [Single axis]

Type selection: Pages 6 – 7

Driven by ball screw

#### BA2-05

Stroke 50 – 500 mm  
Max. payload 6 – 15 kg (horizontal)  
Motor 50 W



See Page 20

#### BA2-07

Stroke 50 – 600 mm  
Max. payload 12 – 30 kg (horizontal)  
Motor 50 W



See Page 21

Driven by ball screw

#### BA2-10

Stroke 100 – 1,050 mm  
Max. payload 15 – 50 kg (horizontal)  
Motor 100 W

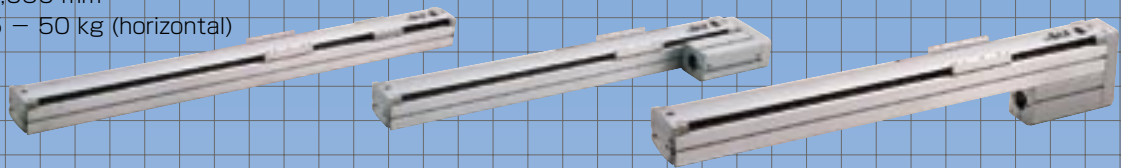

See Pages 22 – 23

Driven by ball screw

#### BA2-30

Stroke 100 – 1,050 mm  
Max. payload 20 – 80 kg (horizontal)  
Motor 100 W  
200 W

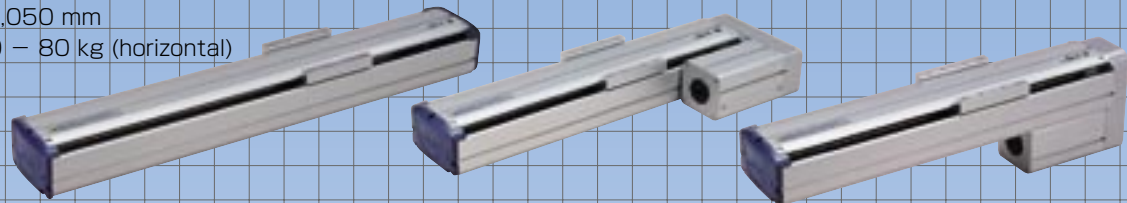

See Pages 24 – 27

Driven by ball screw

#### BA2-50

Stroke 200 – 1,500 mm\*  
Max. payload 60 – 150 kg (horizontal)  
Motor 200 W  
400 W

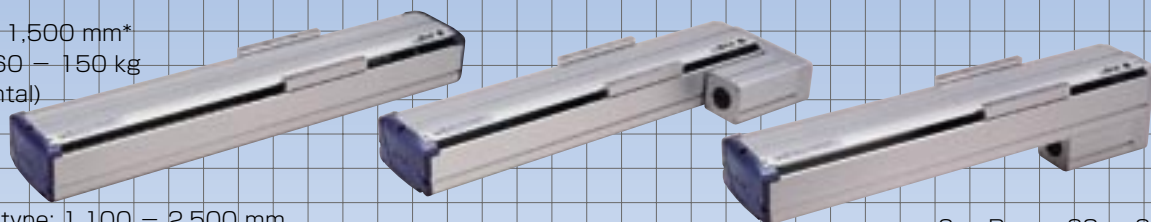

\* Long stroke type: 1,100 – 2,500 mm

See Pages 28 – 33

Driven by timing belt

#### BA2-10

Stroke 100 – 2,500 mm  
Max. payload 10 – 40 kg (horizontal)  
Motor 100 W  
200 W  
400 W



#### BA2-30

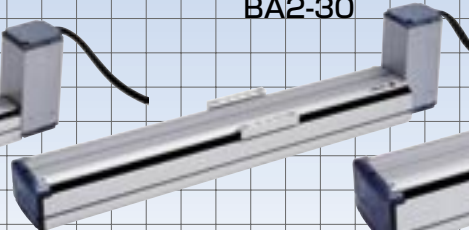

#### BA2-50



See Pages 34 – 45

R-axis

#### BA2-00D-RH

Range of rotation: 360 deg.  
Max. payload 5 kg  
Motor 50 W  
Harmonic drive



#### BA2-00D-RP

Range of rotation: 360 deg.  
Max. payload 10 kg  
Motor 50 W  
Planet gear



See Pages 46 – 47

## [Orthogonal axes]

Type selection: Pages 8 – 12

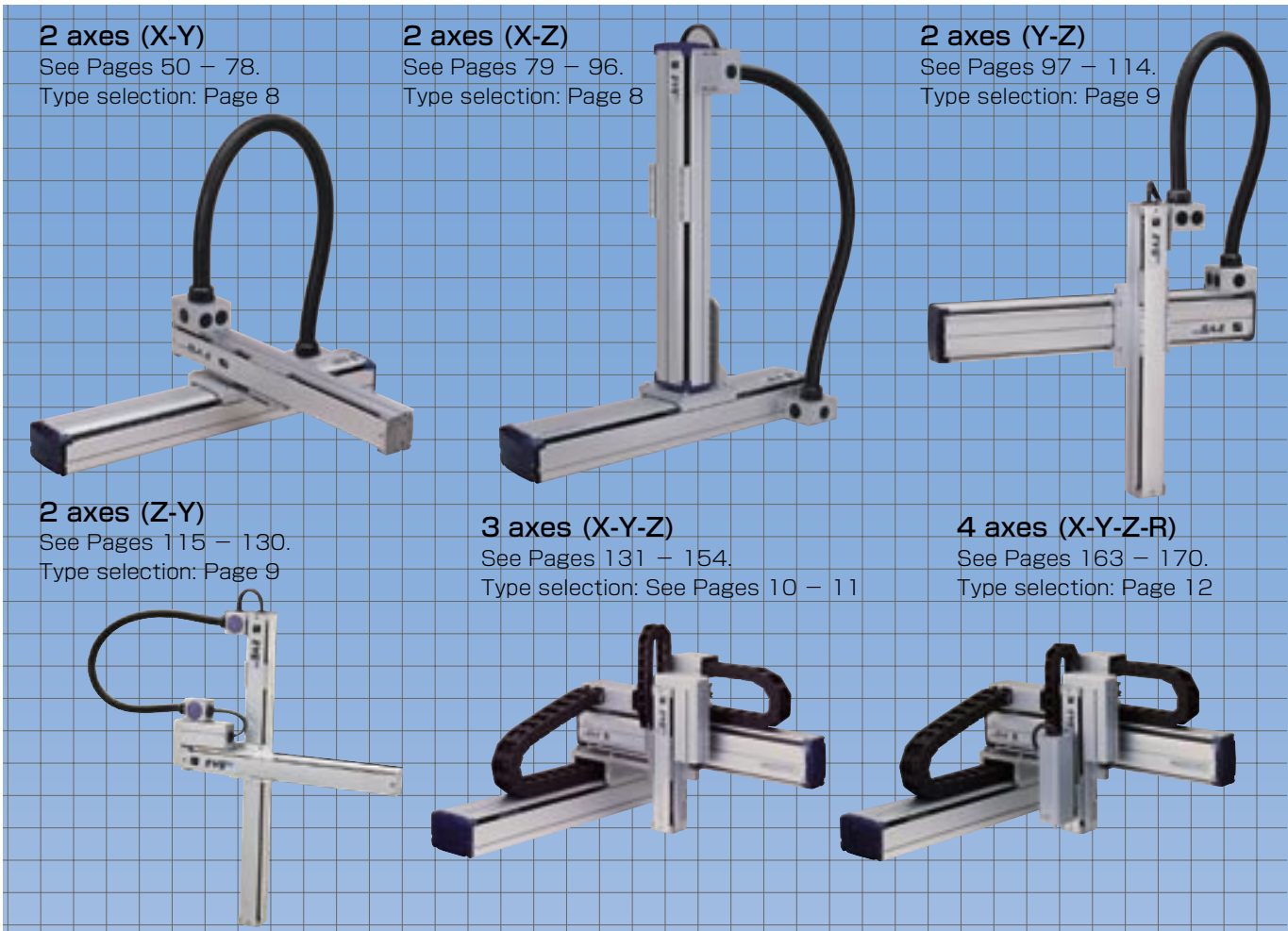

## [Components of control system] Controller

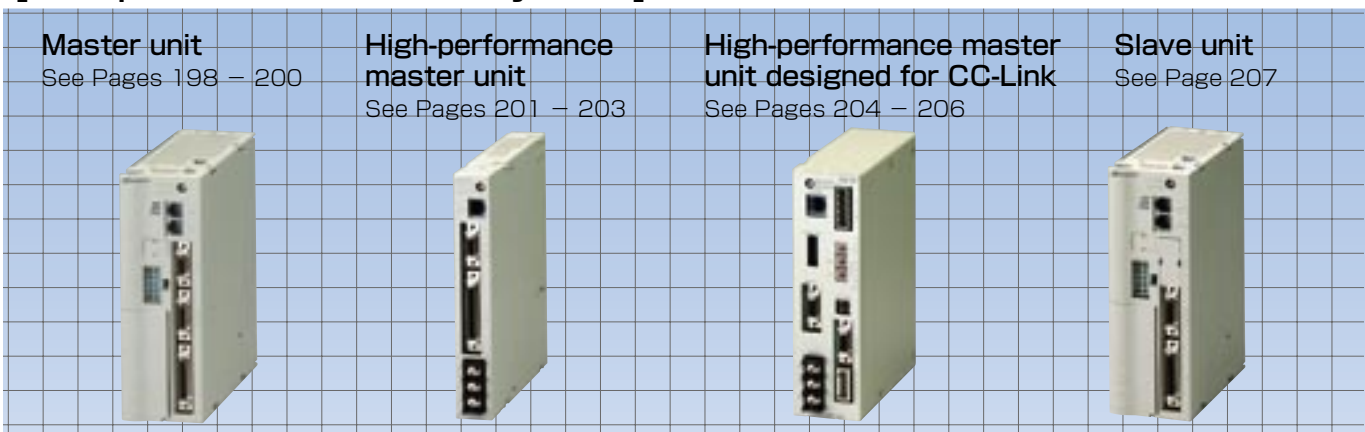

## [Components of control system] Options

☆ Other options are also available.

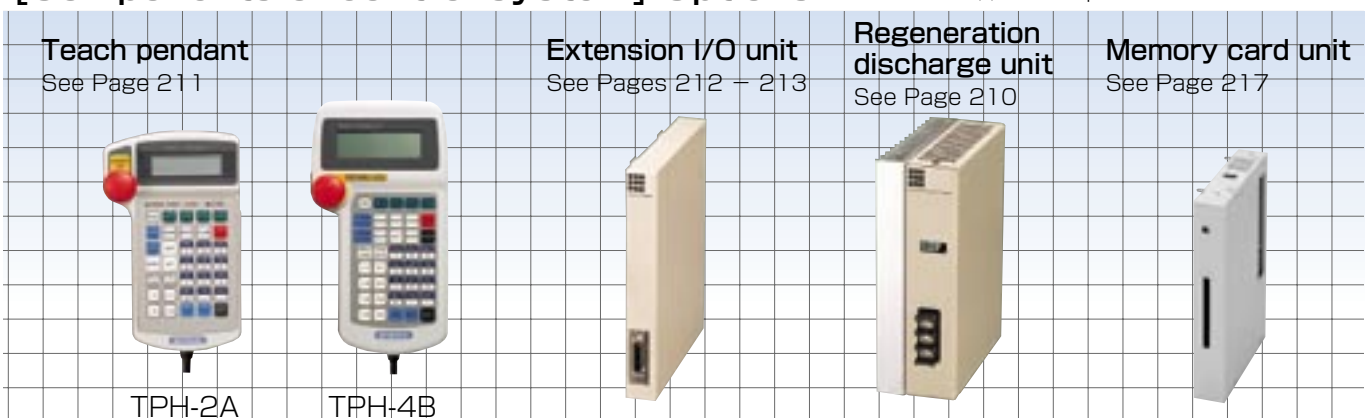



# Type Selection

## Single Axis Specifications

Single axis payload table (horizontal) . . . . .	6
Single axis payload table (vertical, rotation) . . . . .	7

## 2-Axis Combination

2-axis (X-Y) combination payload table . . . . .	8
2-axis (X-Z) combination payload table . . . . .	8
2-axis (Y-Z) combination payload table . . . . .	9
2-axis (Z-Y) combination payload table . . . . .	9

## 3-Axis Combination

3-axis (X-Y-Z) combination payload table . . . . .	10
--	----

## 4-Axis Combination

4-axis (X-Y-Z-R) combination payload table . . . . .	12
--	----

# Single axis payload table (horizontal)

## Ball screw driven

Ref. page	Type	Stroke (mm)	Lead (mm)	Max. speed (mm/s)	Max. payload (kg)
P20	BA2-05D	50 - 500	⓫	800	6
			⓪	400	15
P21	BA2-07D	50 - 600	⓫	800	12
			⓪	400	30
P22 - P23	BA2-10E	100 - 1050	⓫	1200	15
			⓫	600	30
			⓪	300	50
P24 - P25	BA2-30E	100 - 1050	⓫	1200	20
			⓫	600	50
			⓪	300	50
P26 - P27	BA2-30F	100 - 1000	⓫	1200	40
			⓫	600	80
			⓪	300	80
P28 - P29	BA2-50F	200 - 1500	⓫	1200	60
			⓫	600	100
			⓪	300	100
P30 - P31	BA2-50G	200 - 1500	⓫	1200	100
			⓫	600	150
			⓪	300	150
P32 - P33	BA2-50F-LT	1100 - 2500	⓫	1200	60
	BA2-50G-LT	1100 - 2500	⓫	1200	100

## Timing belt driven

P34 - P35	BA2-10E	100 - 1800	⓫	1000	15
P36 - P37	BA2-10F	100 - 1800	⓫	2000	10
			⓫	1000	20
P38 - P39	BA2-30E	100 - 2500	⓫	1000	15
P40 - P41	BA2-30F	100 - 2500	⓫	2000	20
			⓫	1000	40
P42 - P43	BA2-50F	200 - 2500	⓫	1000	20
P44 - P45	BA2-50G	200 - 2500	⓫	2000	20

0 30 60 90 120 150(kg)



## Single axis payload table (vertical) **Ball screw driven**

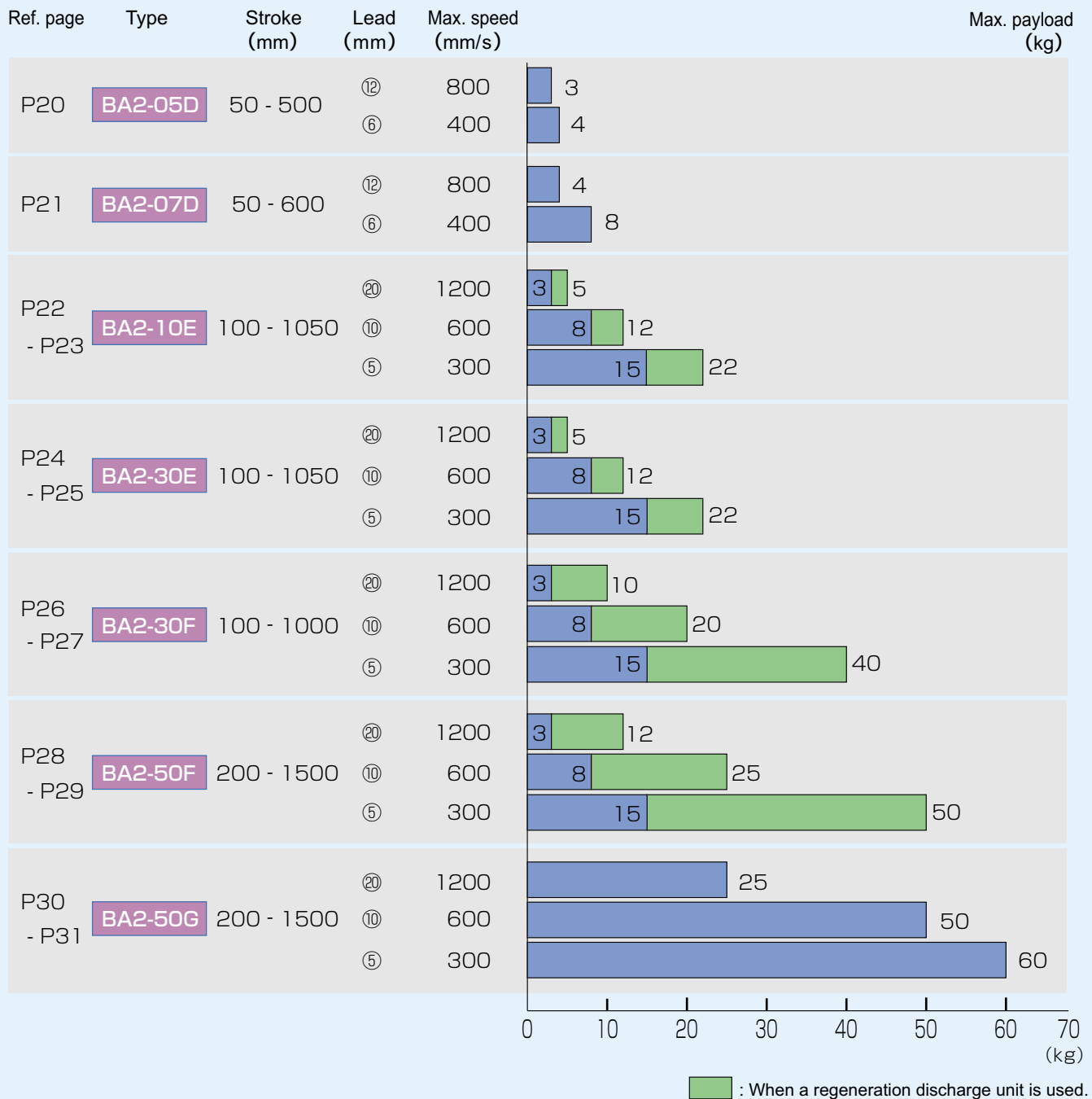

## Single axis payload table (rotation) **Harmonic drive** **Planet gear**

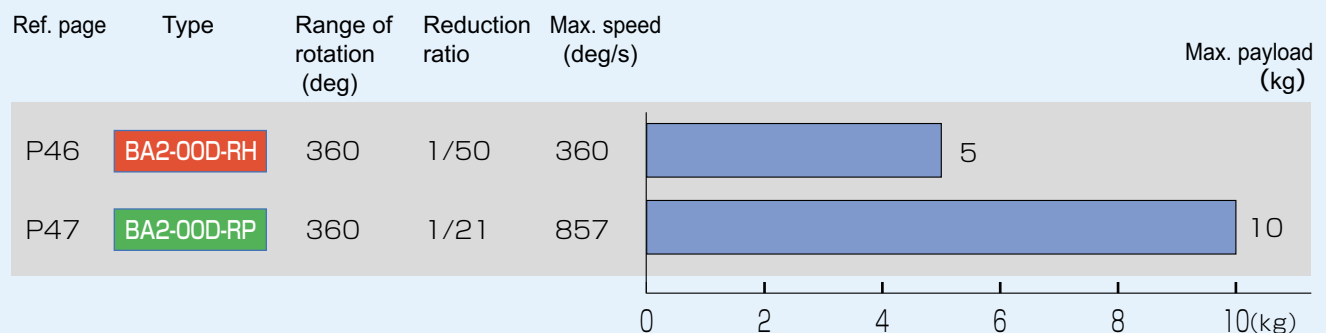

## 2-axis (X-Y) combination payload table

See Pages 50-71

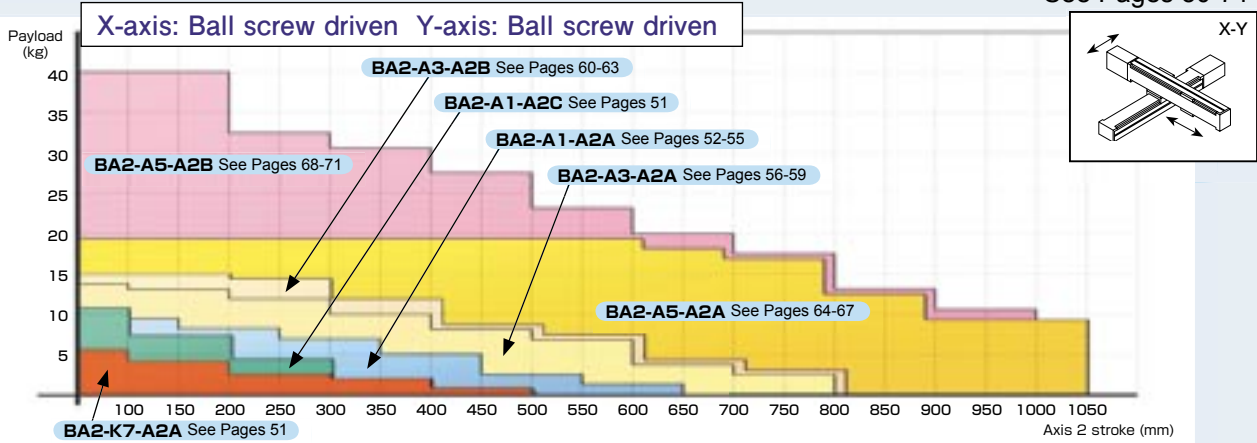

See Pages 72-78

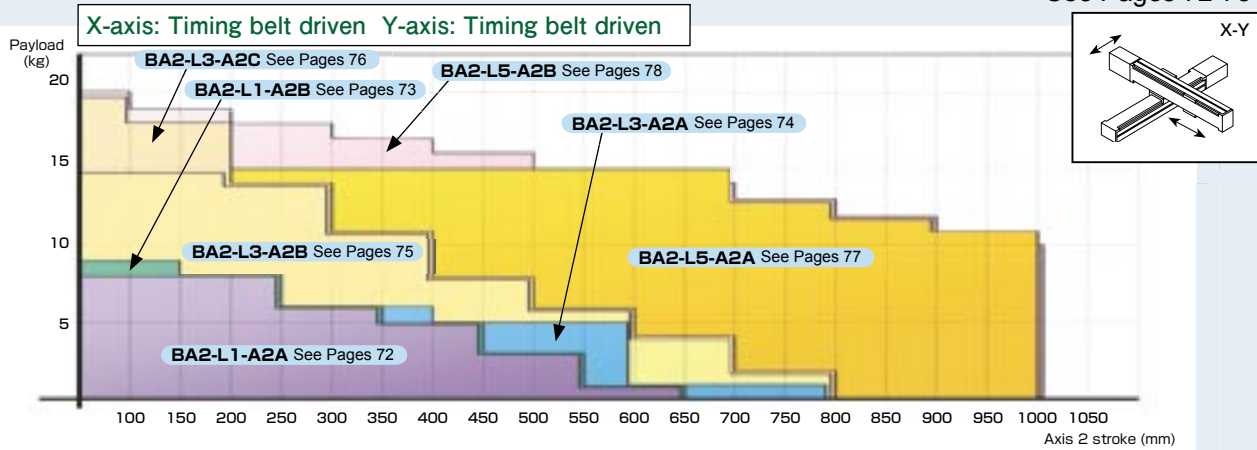

## 2-axis (X-Z) combination payload table

See Pages 79-80

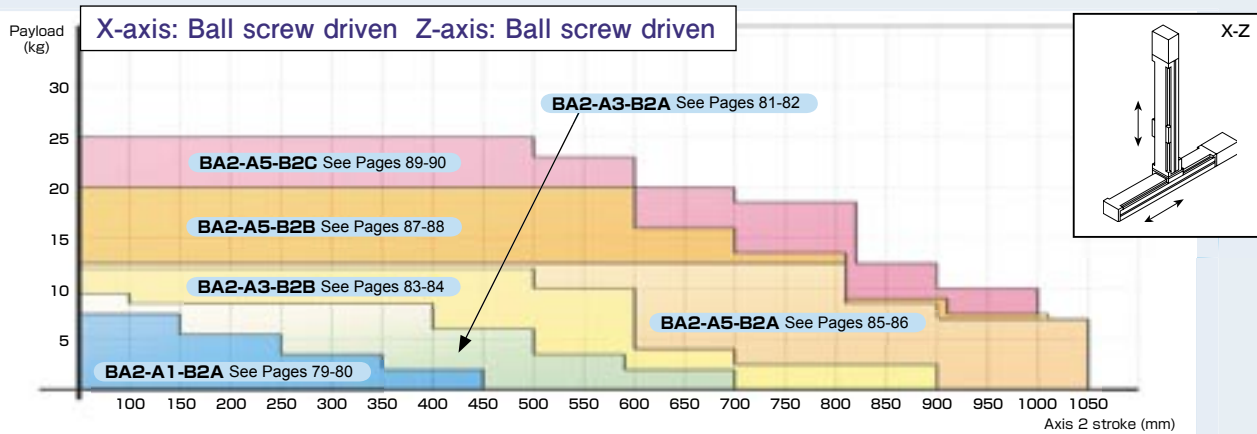

See Pages 91-96

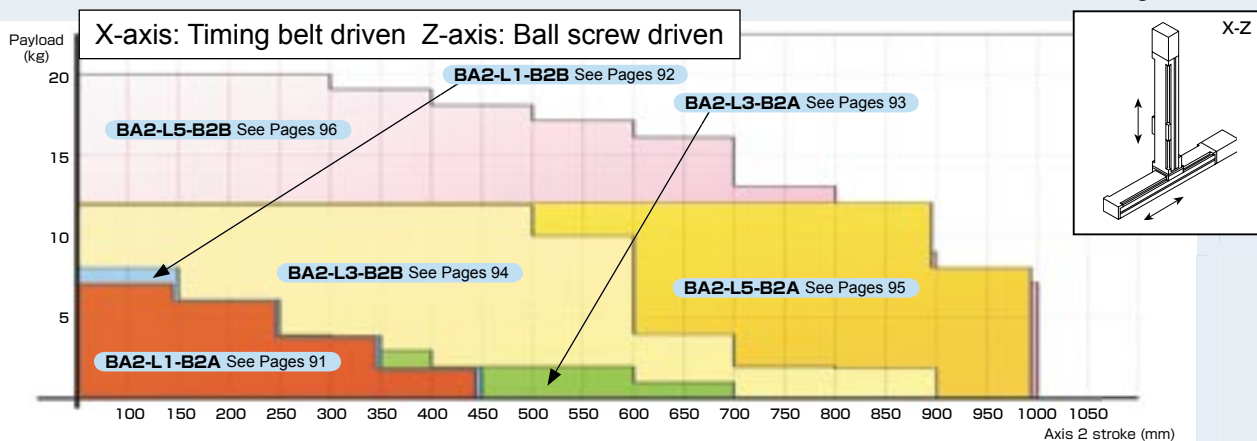

## 2-axis (Y-Z) combination payload table

See Pages 97-108

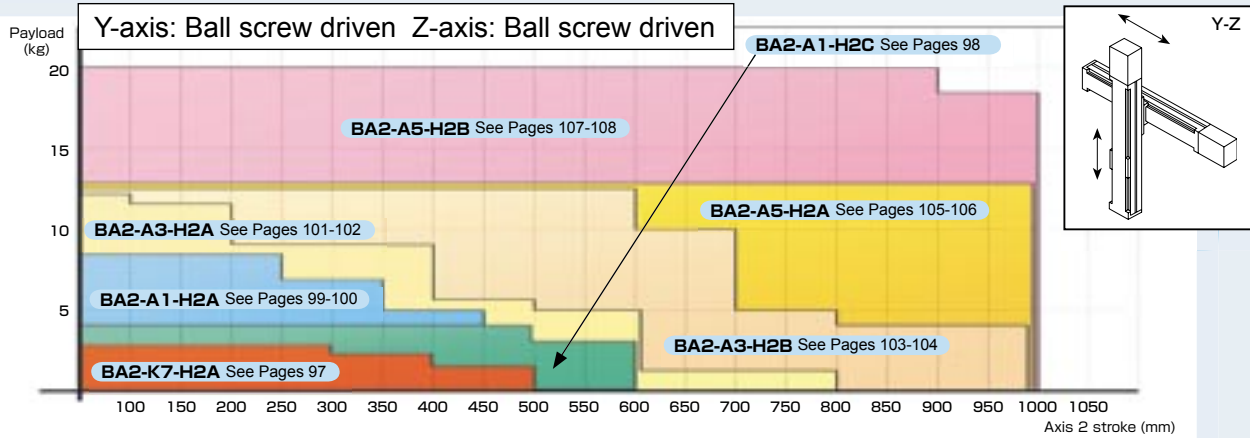

See Pages 109-114

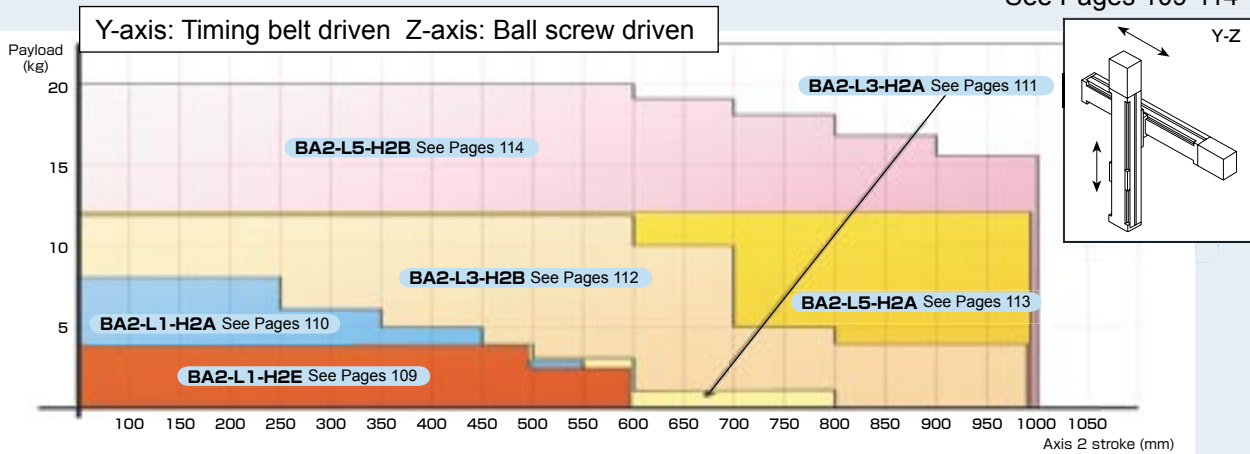

## 2-axis (Z-Y) combination payload table

See Pages 115-124

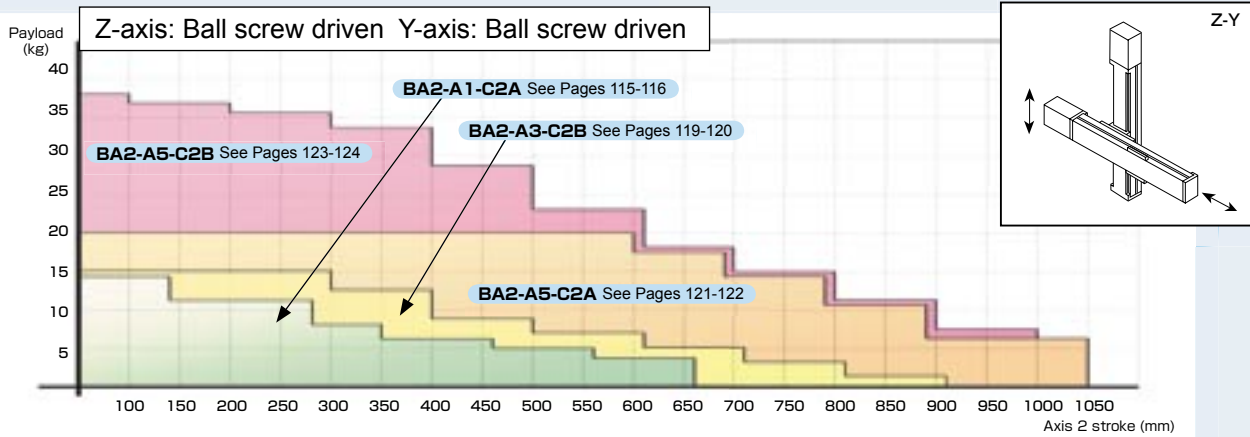

See Pages 125-130

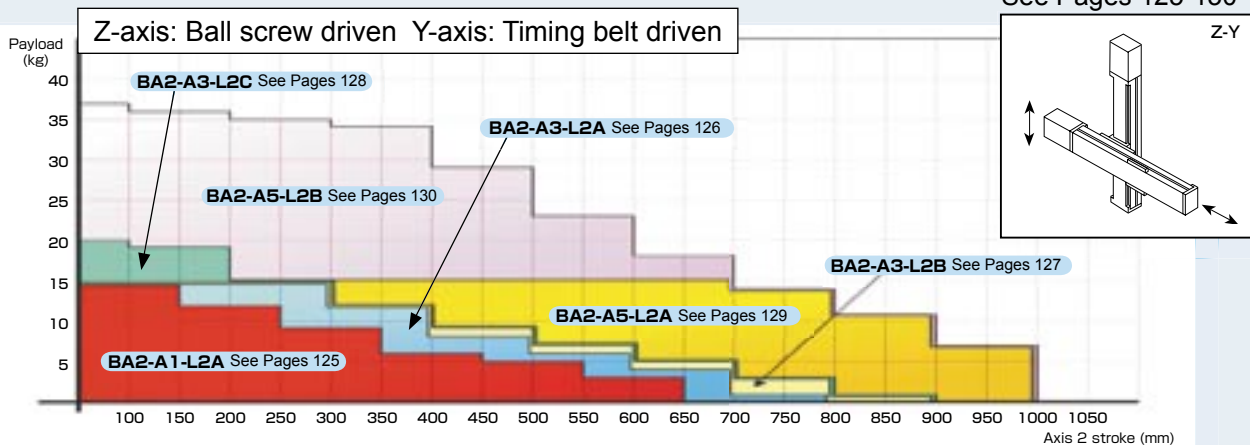

# 3-axis (X-Y-Z) combination payload table

X-axis: Ball screw driven Y-axis: Ball screw driven Z-axis: Ball screw driven

See Pages 131-154

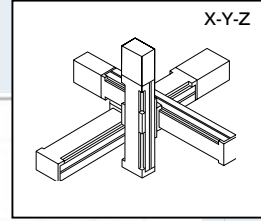

Z-axis stroke: 100, 150 mm

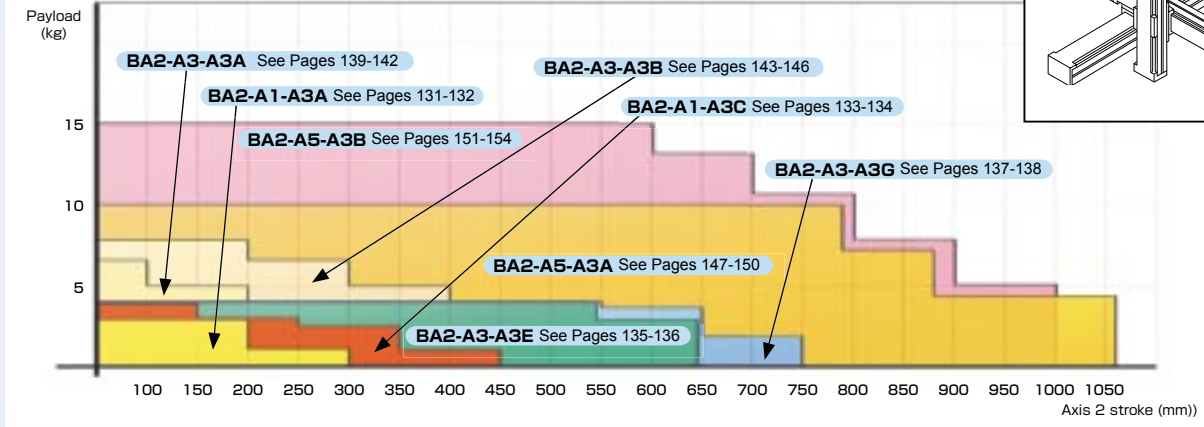

Z-axis stroke: 200, 250 mm

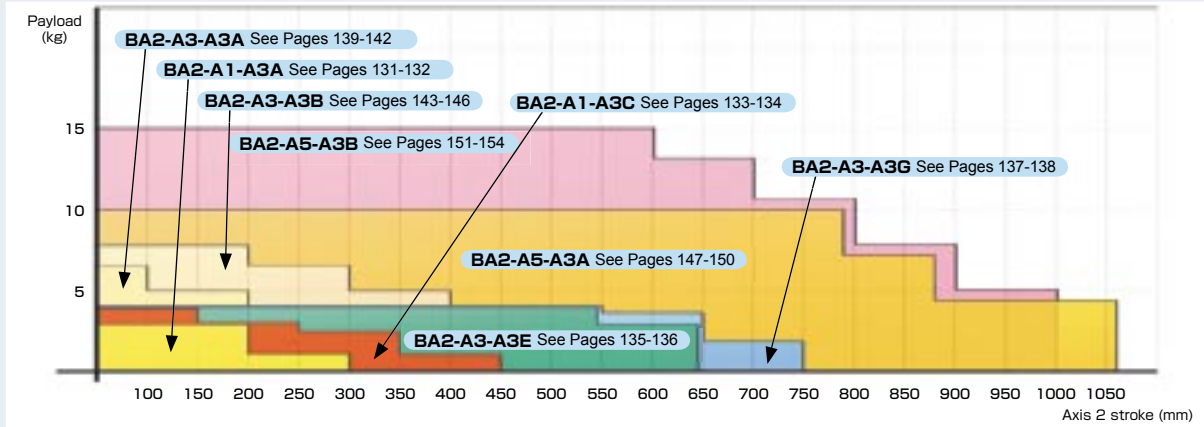

Z-axis stroke: 300, 350 mm

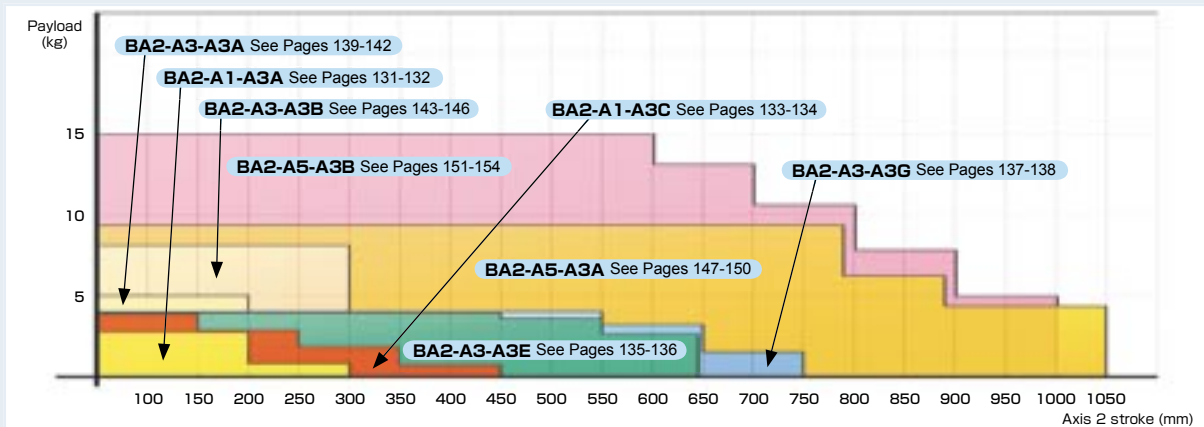

# 3-axis (X-Y-Z) combination payload mass table

X-axis: Timing belt driven Y-axis: Timing belt driven Z-axis: Ball screw driven

See Pages 155-162

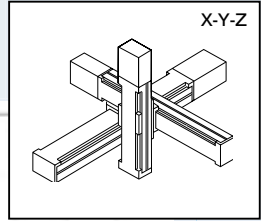

Z-axis stroke: 100, 150 mm

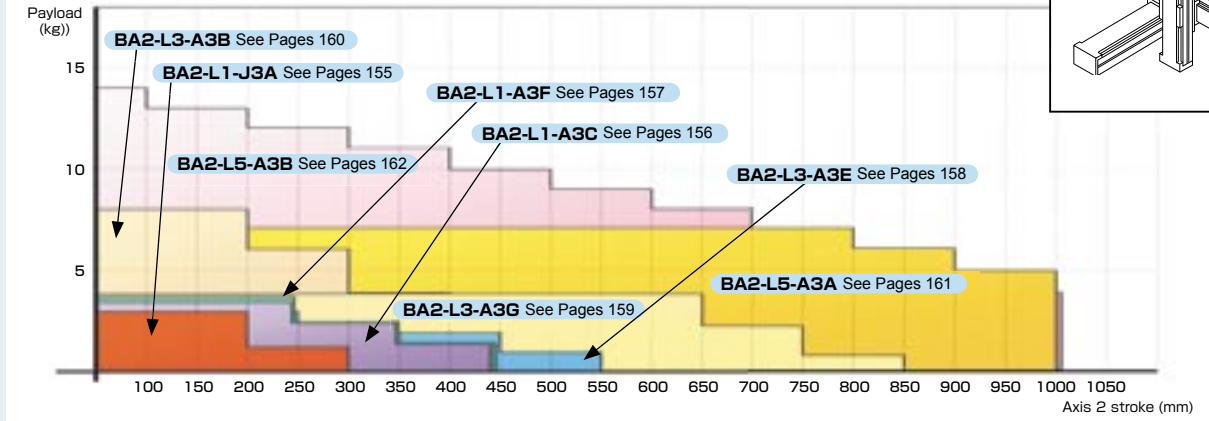

Z-axis stroke: 200, 250 mm

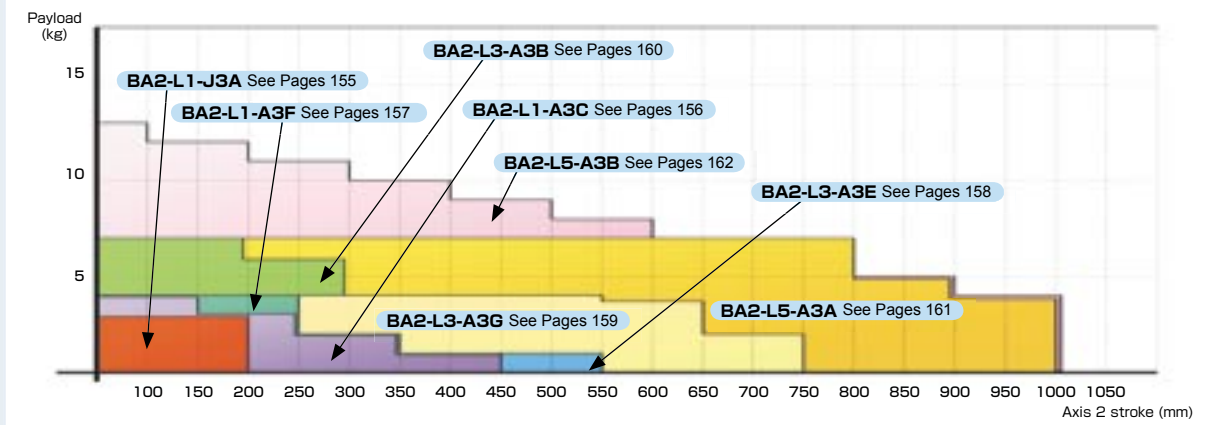

Z-axis stroke: 300, 350 mm

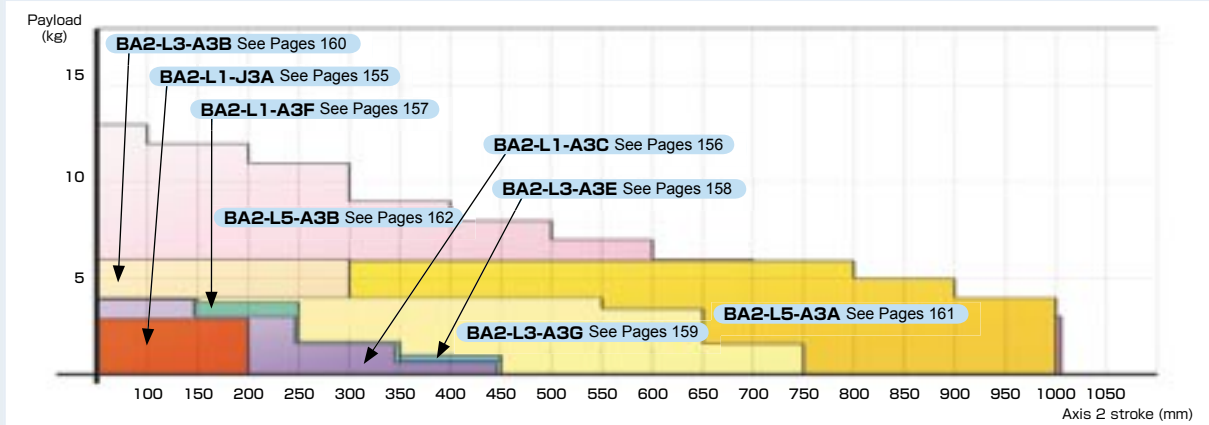

# 4-axis (X-Y-Z-R) combination Payload table

X-axis: Ball screw driven Y-axis: Ball screw driven Z-axis: Ball screw driven R-axis: Rotating axis

See Pages 163-170

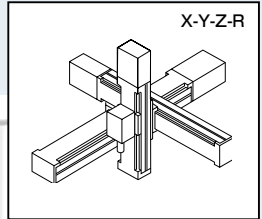

Z-axis stroke: 100, 150 mm

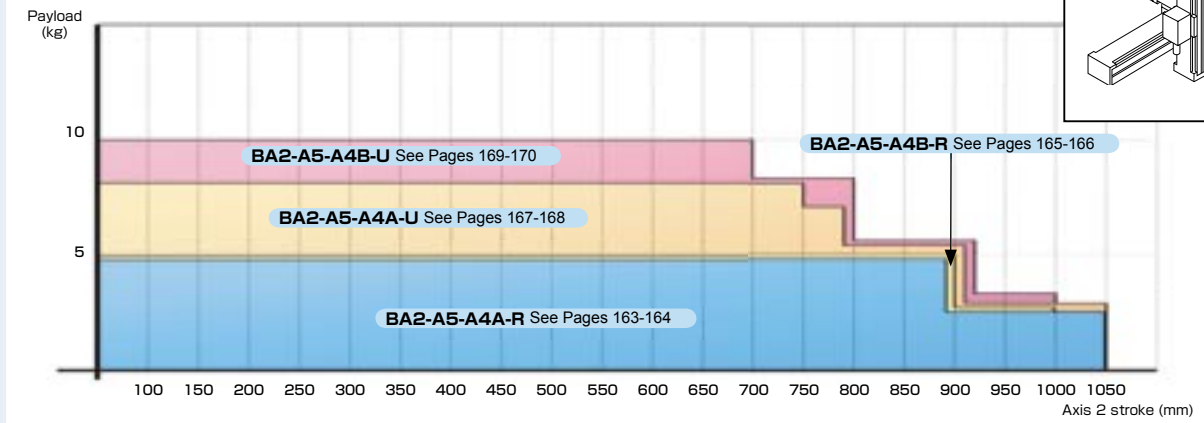

Z-axis stroke: 200, 250 mm

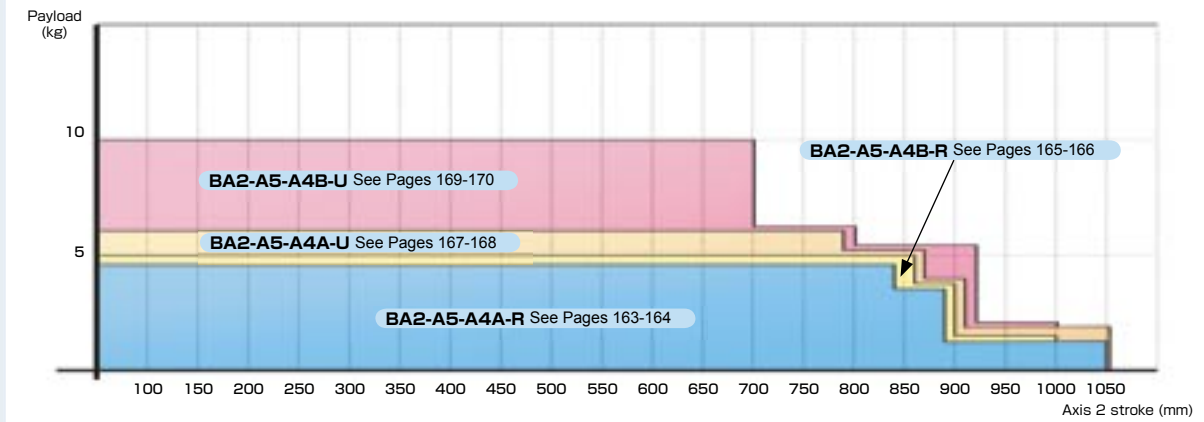

Z-axis stroke: 300, 350 mm

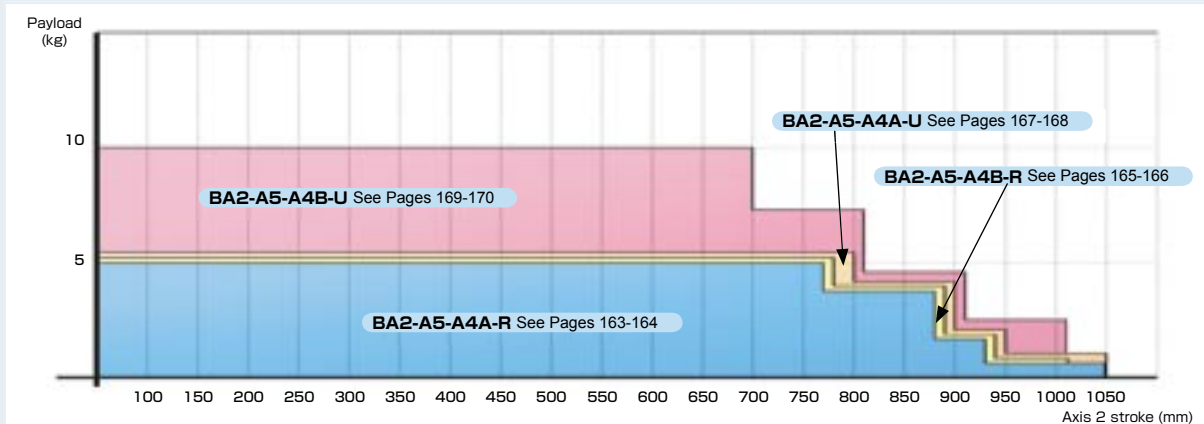

## ■ Example applications

Transfer

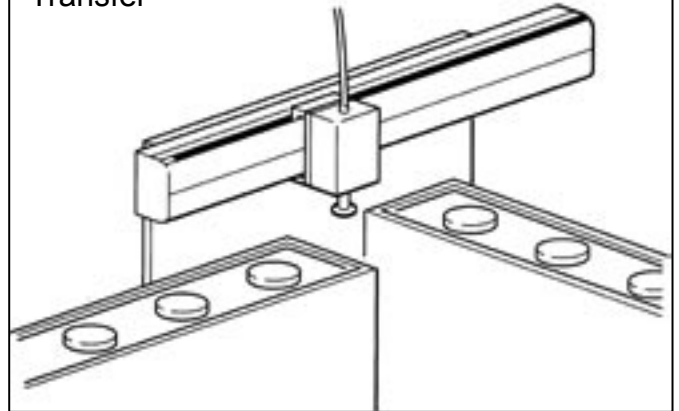

Loading parts

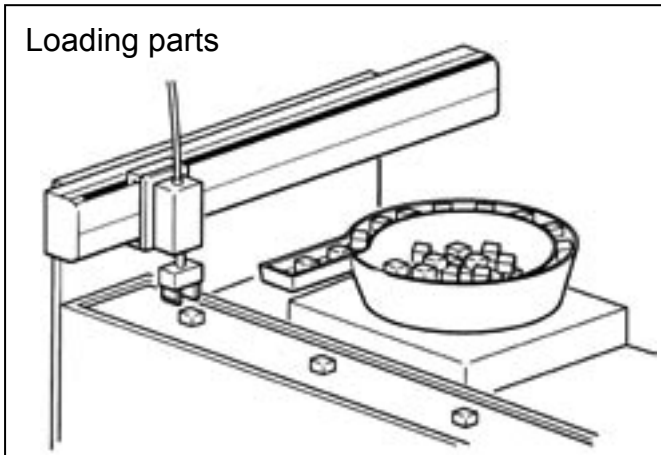

Inspection

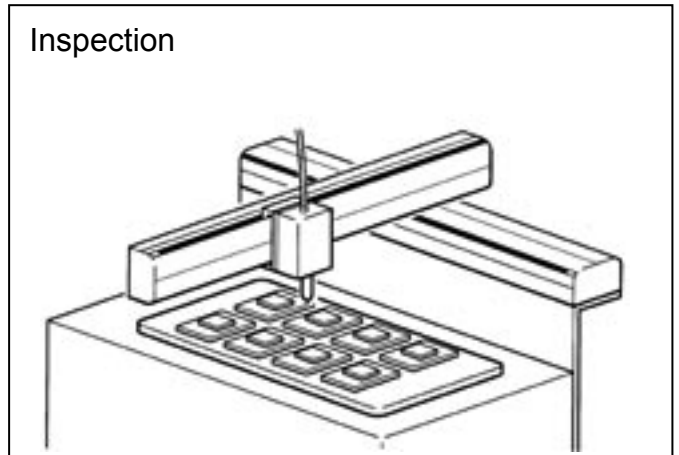

Palletizing

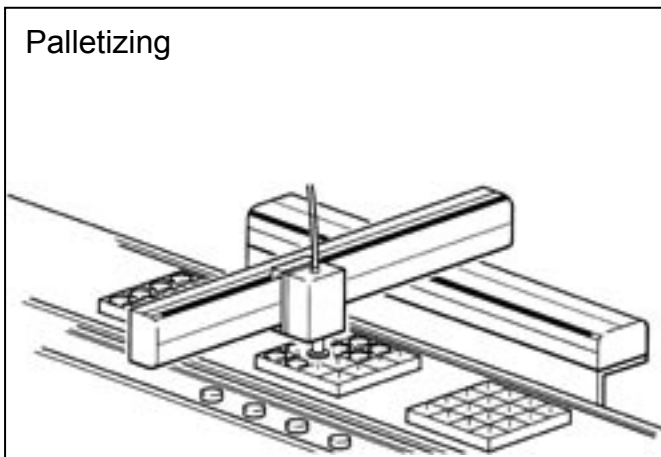

Parts assembly

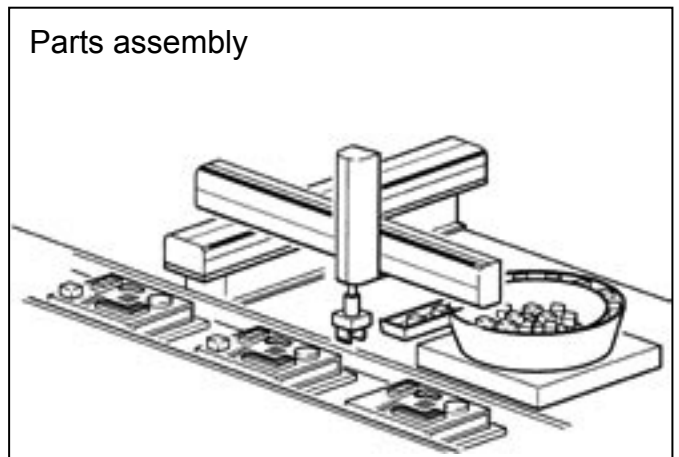

Sealing

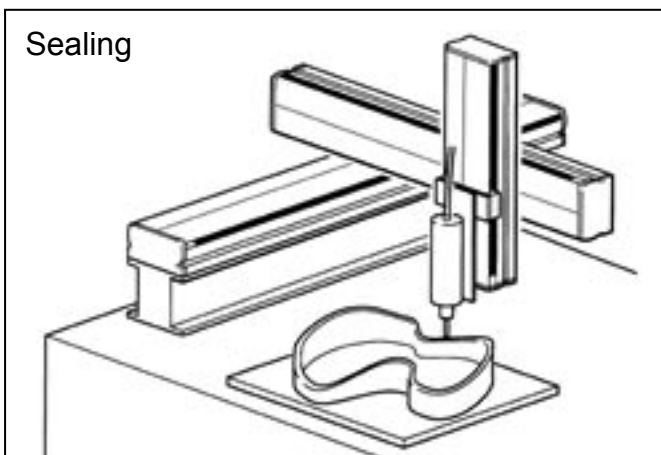

Cutting

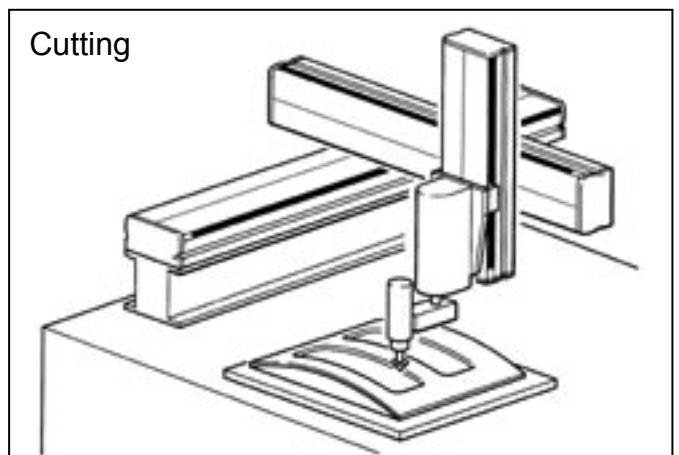

# Before you read this manual

## ■ Definition of terms ■

**[Axis1 and Axis2]** : When forming an orthogonal axes configuration, an axis which is mounted directly on the user-provided equipment is called the “Axis 1”, and the other axis which is mounted on the Axis 1 with a bracket is called the “Axis 2”.

**[Straight axis]** : An axis whose ball screw and servo motor shaft centers are placed along a straight line.

**[Right side mounted axis]** : An axis whose servo motor is turned back, which is coupled with a ball screw via a timing belt. When the motor is located on the right side when seen from the end block side of the actuator with the slider of the actuator facing up, this axis is called the “right side mounted motor axis.” Likewise, when it is located on the left side and bottom side, the axis is called the “left side mounted motor axis” and “bottom side mounted motor axis”, respectively.

**[Long slider type]** : Used for the traveling type axis 2 (BB30, BB50) or for an axis on which large load moment is exerted.

**[Medium slider type]** : Used for the axis 1 of an orthogonal axes configuration or as the standard axis of a single axis configuration.

**[Short slider type]** : Used for a single axis with relatively small load moment or for the axis 2 and axis 3 of an orthogonal axes configuration.

**[Work area]** : The location of the work area is defined by the side (right or left) when viewed from the end block side of the axis 1 in an orthogonal axes configuration.

**[Axis 2 slider motor side]** : When the Axis 2 slider is seen from the end block side of the Axis 1 in an orthogonal axes configuration, it is located on the rear side of the axis. (When the slider is located on the front side (standard), it is called the “slider end side”.

**[Axis traveling type]** : Generally, the frame of the actuator (axis) is secured and the slider moves. For the axis traveling type, the slider is secured and the frame of the actuator moves. A hand or other tooling is attached to the end block at the end of the frame.

**[Table type]** : In a single or orthogonal axes configuration, the slider surface is horizontal and faces up to allow the work from the upper side.

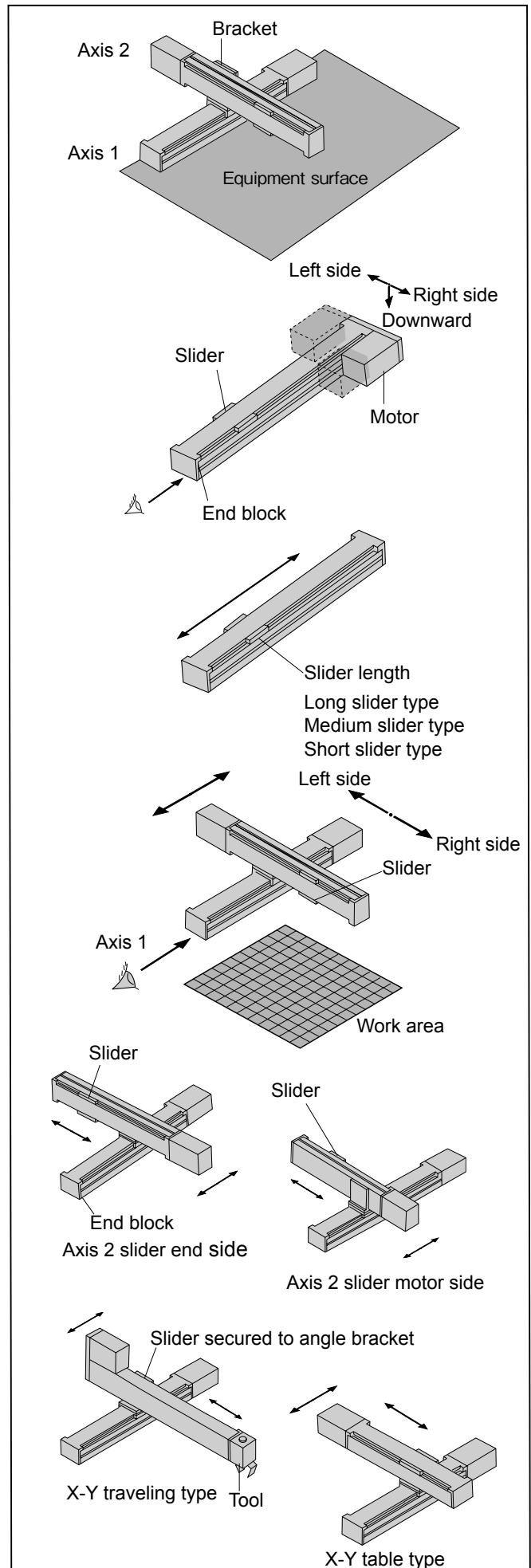



# Terms used in the manual

Terms used throughout this publication are classified into the two groups; general robot terms and those specific to Toshiba Machine robots.

## ■ Terms used for actuator (or axis)

### [Slider]

The part of the actuator which moves along a straight line. A hand or other tooling is assembled to the slider.

When a bracket for axis combination is mounted on the slider, two axes system can be configured.

This is also called the "saddle" in overseas nations.

### [Drive system]

Components for power transformation, such as ball screw and timing belt, which are used to drive the movable part of the actuator.

### [Maximum speed]

Maximum speed (mm/s) which the actuator can attain under specified conditions (payload, for instance).

### [Maximum Payload]

Maximum Payload (kg) under specified conditions (acceleration/ deceleration time, speed, rigidity, service life, etc.).

### [Allowable load moment]

Allowable force (moment) in N-m (kg-m) which acts on the movable part (slide) of the actuator. It comes in two types; static and dynamic.

### [Positioning repeatability]

Repeatability of positioning operations obtained under the same conditions using the same method. The difference between the maximum and minimum values of the result is figured out, then " ± " sign is attached to half the difference.

### [Resolution]

Minimum travel distance of an axis, which can be set during robot teaching.

### [Acceleration/deceleration time (ta)]

The time (seconds) spent until the movable part of the actuator accelerates and reaches its set speed, or the time (seconds) spent until it slows down from its set speed and stops.

This factor is used as a condition for determining the maximum Payload and tact (or cycle) time.

Normally, this value can be specified in a program.

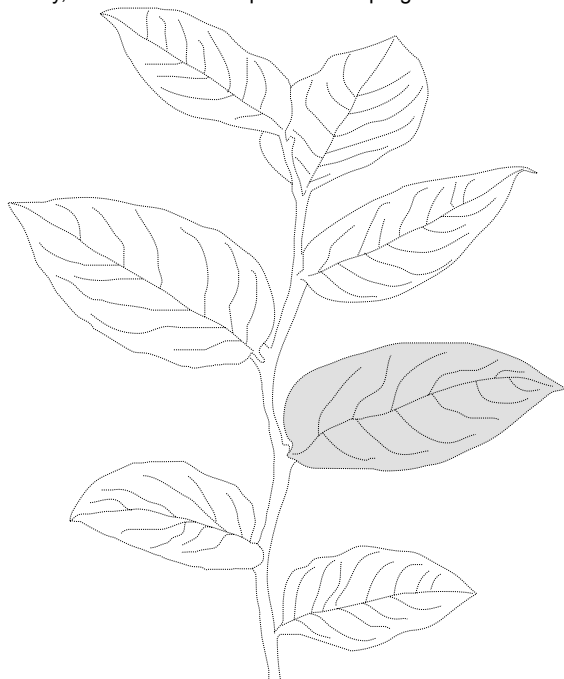

## ■ Terms used for controller

### [Sequential mode]

A mode in which program steps are executed one by one in order.

### [Palletizing mode]

A mode in which traveling and loading operations (i.e., palletizing operation) can be executed easily by specifying points to move, the number of points, etc.

The following motions are available.

- From a given point to another point on a matrix (1 to M)
- From a point on a matrix to a given point (M to 1)
- From a point on a matrix to another point on another matrix (M to M)

### [Easy mode]

A mode in which designation of points to move, call of hand motion routines after movement (i.e., subroutines) and designation of steps to be executed next can be programmed and executed easily without considering any complex program structures. (A regular motion pattern is simply registered as a mode.)

### [External point designation mode]

A mode in which only positioning motions are executed by specifying a PLC (i.e., sequencer) connected to inputs and digital switches, without using normal controller instruction words. Coordinates, speed and acceleration of specified points should be set in the table registered in the controller beforehand.

### [Pulse train input mode]

A mode in which a pulse sent from a pulse generator (positioning controller, etc.) is used to locate the axis in real time at a speed as per its frequency and proportional to the number of pulses.

Two-clock system and 1-clock system are available.

### [Continuous mode]

A mode in which each step of a program is executed sequentially in either of sequential, easy and palletizing modes every time the START pushbutton switch on the teach pendant is pressed. (Normally used mode)

### [Step mode]

A mode in which each single step of program is executed and stopped in either of sequential, easy and palletizing modes every time the START pushbutton switch on the teach pendant is pressed. (Program check mode)

### [Manual mode]

A mode in which a program is executed and stopped after axis feed or input/output command is executed in either of sequential, easy and palletizing modes every time the START pushbutton switch on the teach pendant is pressed or the start input is given. (Test run mode, check mode before day's operation)

### [Remote teaching]

A method of teaching the robot to move to a desired position by pressing move keys on the teach pendant (remote operation) in the servo ON condition.

### [Direct teaching]

A method of directly teaching the robot arm by operator's hand to a desired position and of teaching the robot such a position in the servo OFF condition.

### [MDI (Manual data input)]

A method of directly entering desired coordinates through the keyboard (numerical input) according to the display shown on the teach pendant.

# Selection of single axis specifications

The set designation is shown below. Also refer to Pages 20 to 47.

This page can be used as an order sheet. Enter each quantity, including options.

<b>Set designation</b>	<b>BA2</b> - <input style="width: 20px; height: 20px;" type="text"/> <input style="width: 20px; height: 20px;" type="text"/> <input style="width: 20px; height: 20px;" type="text"/> - <input style="width: 20px; height: 20px;" type="text"/> <input style="width: 20px; height: 20px;" type="text"/> - <input style="width: 20px; height: 20px;" type="text"/> <input style="width: 20px; height: 20px;" type="text"/> <input style="width: 20px; height: 20px;" type="text"/> <input style="width: 20px; height: 20px;" type="text"/> - <input style="width: 20px; height: 20px;" type="text"/> <input style="width: 20px; height: 20px;" type="text"/> - <input style="width: 20px; height: 20px;" type="text"/> <input style="width: 20px; height: 20px;" type="text"/>	Q'ty
	<span style="margin: 0 10px;">①</span> <span style="margin: 0 10px;">②</span> <span style="margin: 0 10px;">③</span> <span style="margin: 0 10px;">④</span> <span style="margin: 0 10px;">⑤</span> <span style="margin: 0 10px;">⑥</span> <span style="margin: 0 10px;">⑦</span> <span style="margin: 0 10px;">⑧</span> <span style="margin: 0 10px;">⑨</span>	

<b>① Type of axis</b> 05 : BB05 07 : BB07 10 : BB10 30 : BB30 50 : BB50 00 : R-axis	<b>② Type of motor</b> D : 50W absolute E : 100W absolute F : 200W absolute G : 400W absolute	<table border="1" style="width: 100%; border-collapse: collapse;"> <tr> <th style="width: 33%;">Ball screw driven</th> <th style="width: 33%;">Timing belt driven</th> <th style="width: 33%;">R-axis</th> </tr> <tr> <td>ST : Straight axis</td> <td>BT : Motor facing up</td> <td>RH : Harmonic drive</td> </tr> <tr> <td>UR : Right side mounted motor axis</td> <td>BU : Motor facing down</td> <td>RP : Planet gear</td> </tr> <tr> <td>UL : Left side mounted motor axis</td> <td>BR : Motor facing right</td> <td></td> </tr> <tr> <td>UU : Bottom side mounted motor axis</td> <td>BL : Motor facing left</td> <td></td> </tr> <tr> <td>LT : Nut rotation</td> <td></td> <td></td> </tr> </table>	Ball screw driven	Timing belt driven	R-axis	ST : Straight axis	BT : Motor facing up	RH : Harmonic drive	UR : Right side mounted motor axis	BU : Motor facing down	RP : Planet gear	UL : Left side mounted motor axis	BR : Motor facing right		UU : Bottom side mounted motor axis	BL : Motor facing left		LT : Nut rotation		
Ball screw driven	Timing belt driven	R-axis																		
ST : Straight axis	BT : Motor facing up	RH : Harmonic drive																		
UR : Right side mounted motor axis	BU : Motor facing down	RP : Planet gear																		
UL : Left side mounted motor axis	BR : Motor facing right																			
UU : Bottom side mounted motor axis	BL : Motor facing left																			
LT : Nut rotation																				

<b>④ Type of slider</b> S: Short slider M: Medium slider L: Long slider A: L type bracket (R-axis) F: Flange type (R-axis)	<table border="1" style="width: 100%; border-collapse: collapse;"> <tr> <th style="width: 33%;">Ball screw driven</th> <th style="width: 33%;">Timing belt driven</th> <th style="width: 33%;">R-axis</th> </tr> <tr> <td>05 : 5 mm</td> <td>21 : 21 mm</td> <td>21: 1/21 (Reduction ratio)</td> </tr> <tr> <td>06 : 6 mm</td> <td>42 : 42 mm</td> <td>50: 1/50 (Reduction ratio)</td> </tr> <tr> <td>10 : 10 mm</td> <td></td> <td></td> </tr> <tr> <td>12 : 12 mm</td> <td></td> <td></td> </tr> <tr> <td>20 : 20 mm</td> <td></td> <td></td> </tr> </table>	Ball screw driven	Timing belt driven	R-axis	05 : 5 mm	21 : 21 mm	21: 1/21 (Reduction ratio)	06 : 6 mm	42 : 42 mm	50: 1/50 (Reduction ratio)	10 : 10 mm			12 : 12 mm			20 : 20 mm			<b>⑥ Brake</b> N: Without brake B: With brake
Ball screw driven	Timing belt driven	R-axis																		
05 : 5 mm	21 : 21 mm	21: 1/21 (Reduction ratio)																		
06 : 6 mm	42 : 42 mm	50: 1/50 (Reduction ratio)																		
10 : 10 mm																				
12 : 12 mm																				
20 : 20 mm																				

<b>⑦ Stroke</b> 10 : 100 mm - 90 : 900 mm A0 : 1000 mm - H0 : 1700 mm J0 : 1800 mm - N0 : 2200 mm P0 : 2300 mm - R0 : 2500 mm 36 : 360 deg. (R-axis)	<b>⑧ Controller</b> 0 : Without controller 1 : CA20-M10, CA20-M40 2 : CA10-M00B 3 : CA10-M01B	<b>⑨ Cable length (between axis(actuator)and controller)</b> 3 : 3 m                      9 : 9 m 5 : 5 m                      B : 11 m 7 : 7 m                      D : 13 m
---	---	--

## Options

Designation	Type	Remarks	Q'ty
I/O cable	CA10-IC-A ⑩ 0	For master unit and slave unit	
	ICBL- ⑩ 00	For high-performance master unit and extension I/O unit (CA10-EX-B40)	
	CA10-IC-B ⑩ 0	For extension I/O unit (CA20-EX-A20)	
	⑩ Cable length 3 : 3 m 5 : 5 m		
Extension I/O unit	CA20-EX-A20	For master unit and slave unit	
	CA10-EX-B40	For high-performance master unit	
Regeneration discharge unit	ABSU-2000	For type of motor 50, 100, 200 W	
	ABSU-4000	For type of motor 400 W	
Home position change sensor	HBS-BA10	For ball screw driven axis	
	HBS-BA20	For timing belt driven axis	
Teach pendant	TPH-2A	For master unit	
	TPH-4B	For high-performance master unit	
Software for personal computer	SF-98D		
Communication cable	PCBL-31		
Memory card unit	CA10-MC-B20	For high-performance master unit	
Link cable	CA10-LC-A ⑪	Required when extending a link cable from standard 150 mm.	
	⑪ Cable length 03:300 mm 10:1000 mm		

## Selection of orthogonal axes specifications

The set designation is shown below. Also refer to Pages 50 to 170.

This page can be used as an order sheet. Enter each quantity, including options.

Set designation	BA2	-	<input type="text"/>	-	<input type="text"/>	<input type="text"/>	<input type="text"/>	<input type="text"/>	<input type="text"/>	-	<input type="text"/>	<input type="text"/>	<input type="text"/>	<input type="text"/>	<input type="text"/>	<input type="text"/>	<input type="text"/>	<input type="text"/>	Qty
		①	②	③	④	⑤	⑥	⑦	⑧	⑨	⑩	⑪							

Type of combined axes structure: Select the combined axes structure (motor direction). } See Pages 50 – 170.  
 Type of combined axes: Select the type of the Axis 2 and on.

### ① Basic axis

Ball screw driven	Timing belt driven
K5 : BB05	L1 : BB10
K7 : BB07	L3 : BB30
A1 : BB10	L5 : BB50
A3 : BB30	
A5 : BB50	

### ② Combined axes structure

- A : X-Y, X-Y-Z, X-Y-Z-R
- B : X-Z
- H : Y-Z
- C : Z-Y (All axes are driven by ball screws.)
- L : Z-Y (Z-axis is driven by ball screw and Y-axis by timing belt.)

### ③ No. of axes

- 1 : 1 axis
- 2 : 2 axes
- 3 : 3 axes
- 4 : 4 axes

### ④ Type of slider

R:Right-handed,2 slider end side

L:Left-handed,2 slider end side

R:Right-handed,2 slider motor side

L:Left-handed,2 slider motor side

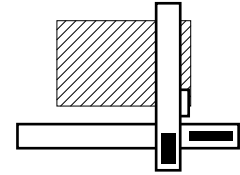
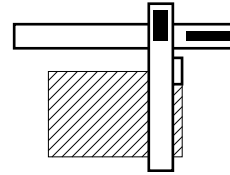
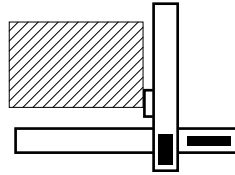
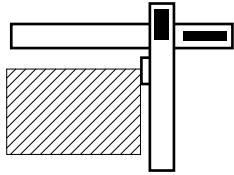

### ⑤ Axis 1 stroke

10 : 100 mm - 90 : 900 mm

### ⑥ Axis 2 stroke

A0 : 1000 mm - H0 : 1700 mm

### ⑦ Axis 3 stroke

J0 : 1800 mm - N0 : 2200 mm

P0 : 2300 mm - R0 : 2500 mm

36 : 360 deg. (R-axis)

### ⑧ R-axis (axis 4)

0 : None

R : Harmonic drive

U : Planet gear

### ⑨ Piping method

0 : None

F : Flexible duct

T : Flexible tube

### ⑩ Controller

0 : Without controller

1 : CA20-M10,CA20-M40

2 : CA10-M00B

3 : CA10-M01B

### ⑪ Cable length (between axis (actuator) and controller)

3 : 3 m

9 : 9 m

5 : 5 m

B : 11 m

7 : 7 m

D : 13 m

## Options

Designation	Type	Remarks	Q'ty
I/O cable	CA10-IC-A ⑫ 0	For master unit and slave unit	
	ICBL- ⑫ 00	For high-performance master unit and extension I/O unit (CA10-EX-B40)	
	CA10-IC-B ⑫ 0	For extension I/O unit (CA20-EX-A20)	
	⑫ Cable length 3 : 3 m 5 : 5 m		
Extension I/O unit	CA20-EX-A20	For master unit and slave unit	
	CA10-EX-B40	For high-performance master unit	
Regeneration discharge unit	ABSU-2000	For type of motor 50, 100, 200 W	
	ABSU-4000	For type of motor 400 W	
Home position change sensor	HBS-BA10	For ball screw driven axis	
	HBS-BA20	For timing belt driven axis	
Teach pendant	TPH-2A	For master unit	
	TPH-4B	For high-performance master unit	
Software for personal computer	SF-98D		
Communication cable	PCBL-31		
Memory card unit	CA10-MC-B20	For high-performance master unit	
Link cable	CA10-LC-A ⑬	Required when extending a link cable from standard 150 mm.	
	⑬ Cable length 03:300 mm 10:1000 mm		



# Single Axis Specifications

## Ball Screw Driven

BA2-05 .....	20
BA2-07 .....	21
BA2-10 .....	22
BA2-30 .....	24
BA2-50 .....	28

## Timing Belt Driven

BA2-10 .....	34
BA2-30 .....	38
BA2-50 .....	42

## R-Axis

BA2-00D-RH .....	46
BA2-00D-RP .....	47

[Set designation]

**BA2 – 05D – ST – M 12 N – 40 – 1 3**

Type of slider M : Medium slider	Lead 06 : 6mm 12 : 12mm	Brake N : Without brake B : With brake	Stroke See "Type designation" under "Stroke" of the specifications below.	Controller 0 : None 1 : CA20 - M10 2 : CA10 - M00B 3 : CA10 - M01B	Cable length 3 : 3m 9 : 9m 5 : 5m B : 11m 7 : 7m D : 13m
-------------------------------------	-------------------------------	--	--	--	---

[Specifications]

Motor	50 W AC servo motor (absolute)		
Drive system	Precisely rolled ball screw (equivalent to C7), thread outer diameter 8 mm		
Stroke (mm) (in increments of 50 mm)	Medium slider	50 ~ 400	450 ~ 500
	Type designation	05 ~ 40	45 ~ 50
Maximum speed (mm/s)	Lead 12 mm	800	600
	Lead 6 mm	400	300
Maximum Payload (kg) Acceleration/deceleration time: 0.3 sec or over	Lead 12 mm	Horizontal transfer: 6 Vertical transfer: 3	
	Lead 6 mm	Horizontal transfer: 15 Vertical transfer: 4	
Positioning repeatability (mm)	±0.02		
Resolution (mm)	0.01		
Allowable static load moment (N·m)	Medium slider MR: 16.0, MP: 6.5, MY: 6.0		
Brake	Braking while not excited, voltage DC24 V		
Master controller	Select from CA20-M10, CA10-M00B and CA10-M01B.		

Notes: \* When using the axis as a vertical axis, select the type with brake.

\* The maximum Payload signifies a load exerted on top of the slider. Also refer to the dynamic load moment given in pages 220 to 227.

\* The acceleration/deceleration time represents the time until the axis reaches a programmed speed.

Ball-screw driven

[Axis designation]

**BB05D – ST – M 12 N – 40**

Type of slider M : Medium slider	Lead 06 : 6mm 12 : 12mm	Brake N : Without brake B : With brake	Stroke See "Type designation" under "Stroke" of the specifications below.
-------------------------------------	-------------------------------	--	--

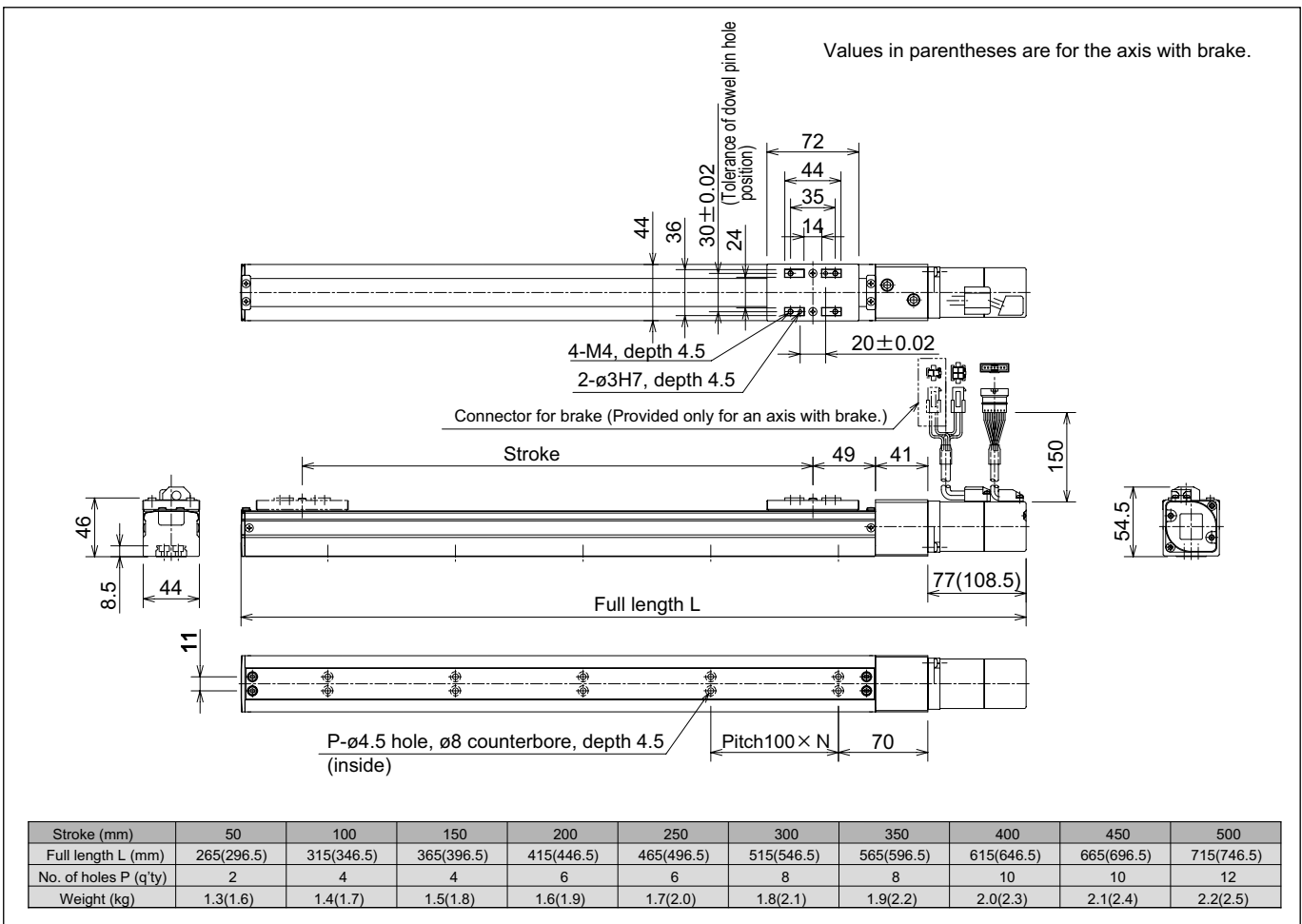

[Set designation]

**BA2 – 07D – ST – M 12 N – 40 – 1 3**

Type of slider M : Medium slider	Lead 06 : 6mm 12 : 12mm	Brake N : Without brake B : With brake	Stroke See "Type designation" under "Stroke" of the specifications below.	Controller 0 : None 1 : CA20 - M10 2 : CA10 - M00B 3 : CA10 - M01B	Cable length 3 : 3m 9 : 9m 5 : 5m B : 11m 7 : 7m D : 13m
-------------------------------------	-------------------------------	--	--	--	---

[Specifications]

Motor	50 W AC servo motor (absolute)			
Drive system	Precisely rolled ball screw (equivalent to C7), thread outer diameter 8 mm			
Stroke (mm) (in increments of 50 mm)	Medium slider	50 ~ 400	450 ~ 500	550 ~ 600
	Type designation	05 ~ 40	45 ~ 50	55 ~ 60
Maximum speed (mm/s)	Lead 12 mm	800	600	400
	Lead 6 mm	400	300	200
Maximum Payload (kg) Acceleration/deceleration time: 0.3 sec or over	Lead 12 mm	Horizontal transfer: 12 Vertical transfer: 4		
	Lead 6 mm	Horizontal transfer: 30 Vertical transfer: 8		
Positioning repeatability (mm)	±0.02			
Resolution (mm)	0.01			
Allowable static load moment (N-m)	Medium slider MR: 32.2, MP: 8.2, MY: 9.9			
Brake	Braking while not excited, voltage DC24 V			
Master controller	Select from CA20-M10, CA10-M00B and CA10-M01B.			

Notes: \* When using the axis as a vertical axis, select the type with brake.

\* The maximum Payload signifies a load exerted on top of the slider. Also refer to the dynamic load moment given in pages 220 to 227.

\* The acceleration/deceleration time represents the time until the axis reaches a programmed speed.

[Axis designation]

**BB07D – ST – M 12 N – 40**

Type of slider M : Medium slider	Lead 06 : 6mm 12 : 12mm	Brake N : Without brake B : With brake	Stroke See "Type designation" under "Stroke" of the specifications below.
-------------------------------------	-------------------------------	--	--

Ball-screw driven

Values in parentheses are for the axis with brake.

Stroke

Full length L

4-M4, depth 9

2-ø3H7, depth 4

Connector for brake (Provided only for an axis with brake.)

P-ø4.5 hole, ø8 counterbore, depth 4.5 (inside)

Pitch 100 × N

Stroke (mm)	50	100	150	200	250	300	350	400	450	500	550	600
Full length L (mm)	282.9(314.9)	332.9(364.4)	382.9(414.4)	432.9(464.4)	482.9(514.5)	532.9(564.5)	582.9(614.5)	632.9(664.5)	682.9(714.5)	732.9(764.5)	782.9(814.5)	832.9(864.5)
No. of holes P (q/ty)	4	4	6	6	8	8	10	10	12	12	14	14
Weight (kg)	1.8(2.1)	2.0(2.3)	2.2(2.5)	2.4(2.7)	2.6(2.9)	2.8(3.1)	3.0(3.3)	3.2(3.5)	3.4(3.7)	3.6(3.9)	3.8(4.1)	4.0(4.3)

[Set designation]

**BA2 – 10E – ST – M 20 N – 40 – 1 3**

Axis structure	Type of slider	Lead	Brake	Stroke	Controller	Cable length
ST: Straight axis UR: Right side mounted motor axis UL: Left side mounted motor axis UU: Bottom side mounted motor axis	S: Short slider M: Medium slider	05: 5mm 10: 10mm 20: 20mm	N: Without brake B: With brake	See "Type designation" under "Stroke" of the specifications below.	0: None 1: CA20 - M10 2: CA10 - M00B 3: CA10 - M01B	3: 3m 9: 9m 5: 5m B: 11m 7: 7m D: 13m

[Specifications]

Motor	100 W AC servo motor (absolute)				
Drive system	Ground ball screw (C7), thread outer diameter 15 mm				
Stroke (mm) (in increments of 100 mm)	Short slider	150 ~ 650	750	850	950, 1050
	Type designation	15 ~ 65	75	85	95, A5
	Medium slider	100 ~ 600	700	800	900, 1000
	Type designation	10 ~ 60	70	80	90, A0
Maximum speed (mm/s) Values in < > signify the acceleration/deceleration time in seconds when the maximum Payload is loaded.	Lead 20 mm	1200<0.36>	1000<0.3>	800<0.24>	600<0.18>
	Lead 10 mm	600<0.36>	500<0.3>	400<0.24>	300<0.18>
	Lead 5 mm	300<0.36>	250<0.3>	200<0.24>	150<0.18>
Maximum Payload (kg)	Lead 20 mm	Horizontal transfer: 15		Vertical transfer: 3 (5)	
	Lead 10 mm	Horizontal transfer: 30		Vertical transfer: 8 (12)	
	Lead 5 mm	Horizontal transfer: 50		Vertical transfer: 15 (22)	
Positioning repeatability (mm)	±0.01				
Resolution (mm)	0.01				
Allowable static load moment (N-m)	Short slider MR: 49, MP: 14, MY: 13 Medium slider MR: 59, MP: 59, MY: 54				
Brake	Braking while not excited, voltage DC24 V				
Master controller	Select from CA20-M10, CA10-M00B and CA10-M01B.				

- Notes: \* When using the axis as a vertical axis, select the type with brake.  
 \* The maximum Payload signifies a load exerted on top of the slider. Also refer to the dynamic load moment given in pages 220 to 227.  
 \* The values in parentheses under "Maximum Payload" are applicable when a regeneration discharge unit ABSU-2000 is equipped.  
 \* The acceleration/deceleration time represents the time until the axis reaches a programmed speed.

Ball-screw driven

[Axis designation]

**BB10E – ST – M 20 N – 40**

Axis structure	Type of slider	Lead	Brake	Stroke
ST: Straight axis UR: Right side mounted motor axis UL: Left side mounted motor axis UU: Bottom side mounted motor axis	S: Short slider M: Medium slider	05: 5mm 10: 10mm 20: 20mm	N: Without brake B: With brake	See "Type designation" under "Stroke" of the specifications below.

[Dimensions]

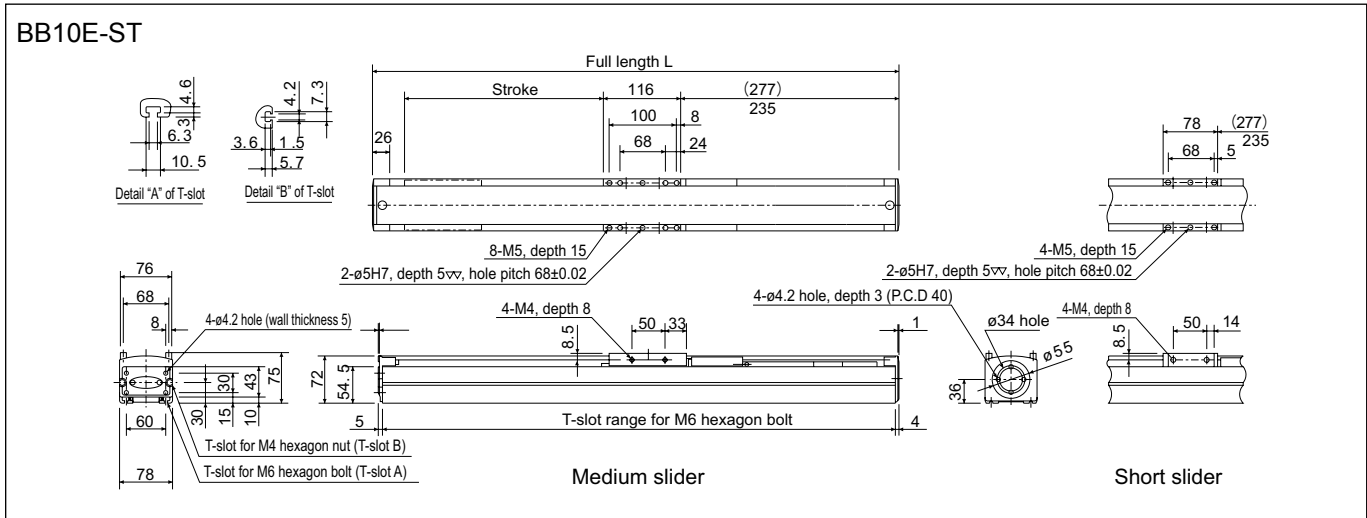

Medium slider	Stroke (mm)	100	200	300	400	500	600	700	800	900	1000
	Full length L (mm)	498(540)	598(640)	698(740)	798(840)	898(940)	998(1040)	1098(1140)	1198(1240)	1298(1340)	1398(1440)
	Weight (kg)	4.9(5.3)	5.6(6.0)	6.3(6.7)	7.0(7.4)	7.7(8.1)	8.4(8.8)	9.1(9.5)	9.8(10.2)	10.5(10.9)	11.2(11.6)

\* Values in parentheses are for the axis with brake.

Short slider	Stroke (mm)	150	250	350	450	550	650	750	850	950	1050
	Full length L (mm)	498(540)	598(640)	698(740)	798(840)	898(940)	998(1040)	1098(1140)	1198(1240)	1298(1340)	1398(1440)
	Weight (kg)	4.6(5.0)	5.3(5.7)	6.0(6.4)	6.7(7.1)	7.4(7.8)	8.1(8.8)	8.8(9.2)	9.5(9.9)	10.2(10.6)	10.9(11.3)

\* Values in parentheses are for the axis with brake.



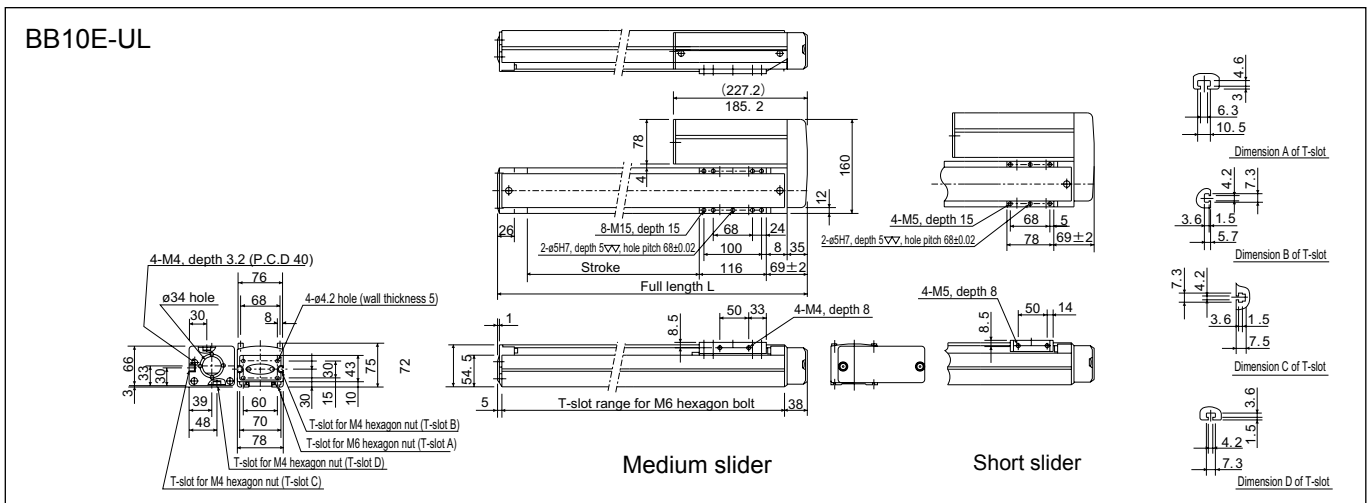
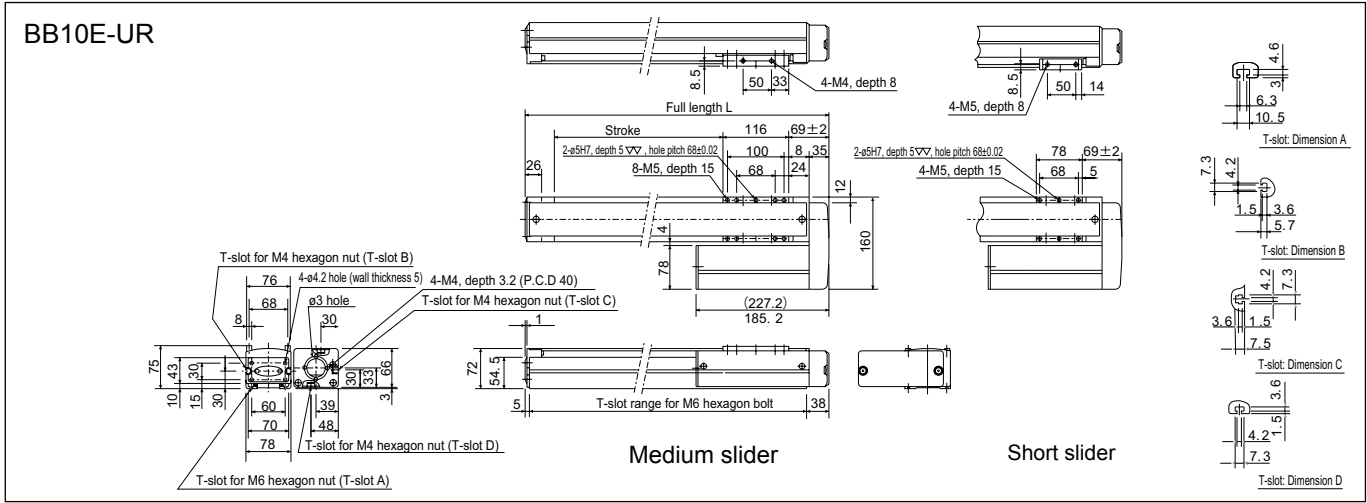

Common to BB10E-UR and UL.

Medium slider	Stroke (mm)	100	200	300	400	500	600	700	800	900	1000
	Full length L (mm)	332	432	532	632	732	832	932	1032	1132	1232
	Weight (kg)	5.0(5.4)	5.7(6.1)	6.4(6.8)	7.1(7.5)	7.8(8.2)	8.5(8.9)	9.2(9.6)	9.9(10.3)	10.6(11.0)	11.3(11.7)

Short slider	Stroke (mm)	150	250	350	450	550	650	750	850	950	1050
	Full length L (mm)	332	432	532	632	732	832	932	1032	1132	1232
	Weight (kg)	4.7(5.1)	5.4(5.8)	6.1(6.5)	6.8(7.2)	7.5(7.9)	8.2(8.6)	8.9(9.3)	9.6(10.0)	10.3(10.7)	11.0(11.4)

\* Values in parentheses are for the axis with brake.

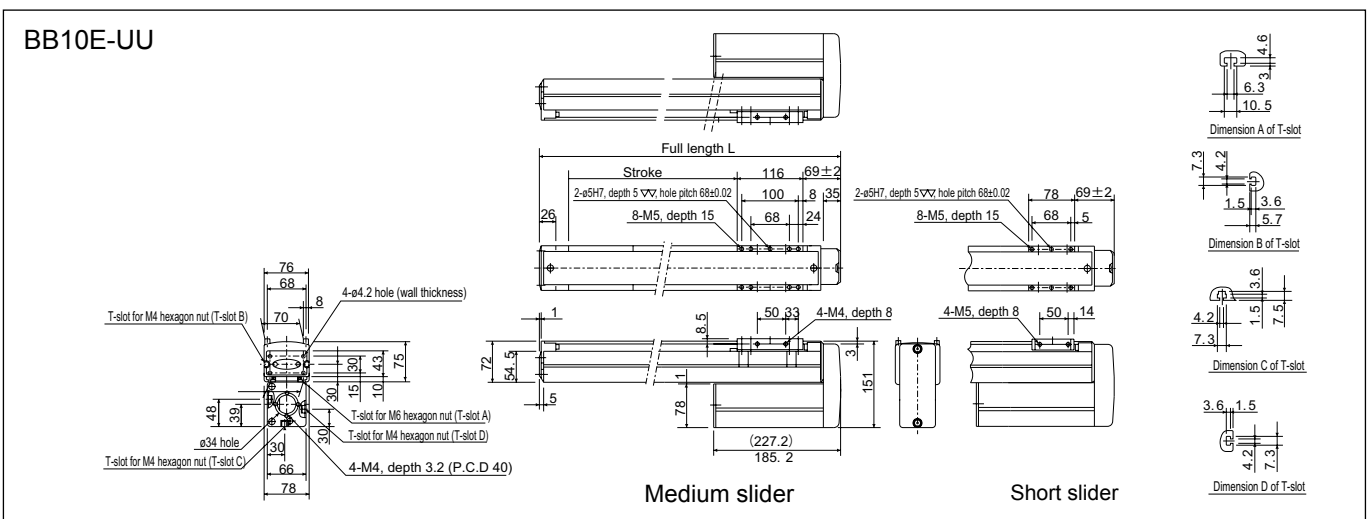

BB10E-UU

Medium slider	Stroke (mm)	200	300	400	500	600	700	800	900	1000
	Full length L (mm)	432	532	632	732	832	932	1032	1132	1232
	Weight (kg)	5.7(6.1)	6.4(6.8)	7.1(7.5)	7.8(8.2)	8.5(8.9)	9.2(9.6)	9.9(10.3)	10.6(11.0)	11.3(11.7)

Short slider	Stroke (mm)	250	350	450	550	650	750	850	950	1050
	Full length L (mm)	432	532	632	732	832	932	1032	1132	1232
	Weight (kg)	5.4(5.8)	6.1(6.5)	6.8(7.2)	7.5(7.9)	8.2(8.6)	8.9(9.3)	9.6(10.0)	10.3(10.7)	11.0(11.4)

\* Values in parentheses are for the axis with brake.

[Set designation]

**BA2 – 30E – ST – M 20 N – 45 – 1 3**

Axis structure	Type of slider	Lead	Brake	Stroke	Controller	Cable length
ST: Straight axis UR: Right side mounted motor axis UL: Left side mounted motor axis UU: Bottom side mounted motor axis	S: Short slider M: Medium slider	05 : 5mm 10 : 10mm 20 : 20mm	N : Without brake B : With brake	See "Type designation" under "Stroke" of the specifications.	0: None 1: CA20 - M10 2: CA10 - M00B 3: CA10 - M01B	3 : 3m 9 : 9m 5 : 5m B : 11m 7 : 7m D : 13m

[Specifications]

Motor	100 W AC servo motor (absolute)				
Drive system	Ground ball screw (equivalent to C7), thread outer diameter 15 mm				
Stroke (mm) (in increments of 100 mm)	Medium slider	100 ~ 600 [150 ~ 650]	700 [750]	800 [850]	900, 1000 [950, 1050]
	Type designation	10 ~ 60 [15 ~ 65]	70 [75]	80 [85]	90, A0 [95, A5]
	Long slider	150 ~ 550 [150 ~ 650]	650 [750]	750 [850]	850, 950 [950]
Values in [ ] for ST :Straight	Type designation	15 ~ 55 [15 ~ 65]	65 [75]	75 [85]	85, 95 [95]
Maximum speed (mm/s) Values in <> signify the acceleration/deceleration time in seconds when the maximum Payload is loaded.	Lead 20 mm	1200<0.36>	1000<0.3>	800<0.24>	600<0.18>
	Lead 10 mm	600<0.36>	500<0.3>	400<0.24>	300<0.18>
	Lead 5 mm	300<0.36>	250<0.3>	200<0.24>	150<0.18>
Maximum Payload (kg)	Lead 20 mm	Horizontal transfer: 20 Vertical transfer: 3 (5)			
	Lead 10 mm	Horizontal transfer: 50 Vertical transfer: 8 (12)			
	Lead 5 mm	Horizontal transfer: 50 Vertical transfer: 15 (22)			
Positioning repeatability (mm)	±0.01				
Resolution (mm)	0.01				
Allowable static load moment (N·m)	Medium slider MR: 510, MP: 430, MY: 370 Long slider MR: 510, MP: 750, MY: 650				
Brake	Braking while not excited, voltage DC24 V				
Master controller	Select from CA20-M10, CA10-M00B and CA10-M01B.				

- Notes:
- \* When using the axis as a vertical axis, select the type with brake.
  - \* The maximum Payload signifies a load exerted on top of the slider. Also refer to the dynamic load moment given in pages 220 to 227.
  - \* The values in parentheses under "Maximum Payload" are applicable when a regeneration discharge unit (ABSU-2000) is equipped.
  - \* The acceleration/deceleration time represents the time until the axis reaches a programmed speed.

Ball-screw driven

[Axis designation]

**BB30E – ST – M 20 N – 45**

Axis structure	Type of slider	Lead	Brake	Stroke
ST: Straight axis UR: Right side mounted motor axis UL: Left side mounted motor axis UU: Bottom side mounted motor axis	M: Medium slider L: Long slider	05 : 5mm 10 : 10mm 20 : 20mm	N : Without brake B : With brake	See "Type designation" under "Stroke" of the specifications.

[Dimensions]

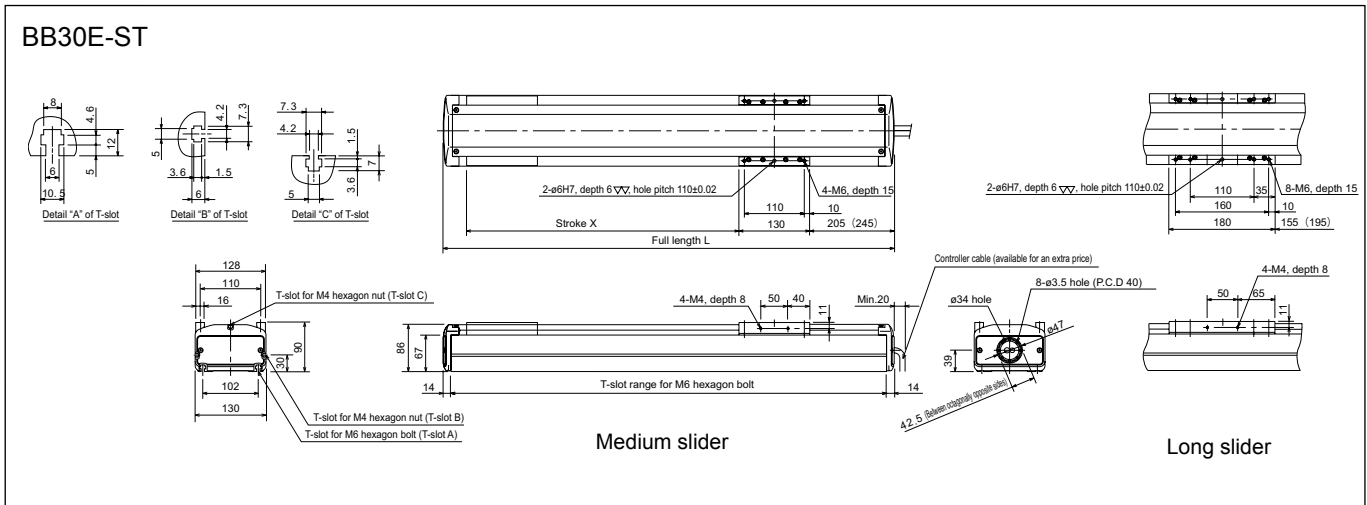

Medium slider	Stroke (mm)	150	250	350	450	550	650	750	850	950	1050
	Full length L (mm)	528(568)	628(668)	728(768)	828(868)	928(968)	1028(1068)	1128(1168)	1228(1268)	1328(1368)	1428(1468)
	Weight (kg)	8.3(8.9)	9.5(10.1)	10.7(11.3)	11.9(12.5)	13.1(13.7)	14.3(14.9)	15.5(16.1)	16.7(17.3)	17.9(18.5)	19.1(19.7)
Long slider	Stroke (mm)	150	250	350	450	550	650	750	850	950	1050
	Full length L (mm)	528(568)	628(668)	728(768)	828(868)	928(968)	1028(1068)	1128(1168)	1228(1268)	1328(1368)	1428(1468)
	Weight (kg)	8.6(9.2)	9.8(10.4)	11.0(11.6)	12.2(12.8)	13.4(14.0)	14.6(15.2)	15.8(16.4)	17.0(17.6)	18.2(18.8)	19.4(20.0)

\* Values in parentheses are for the axis with brake.

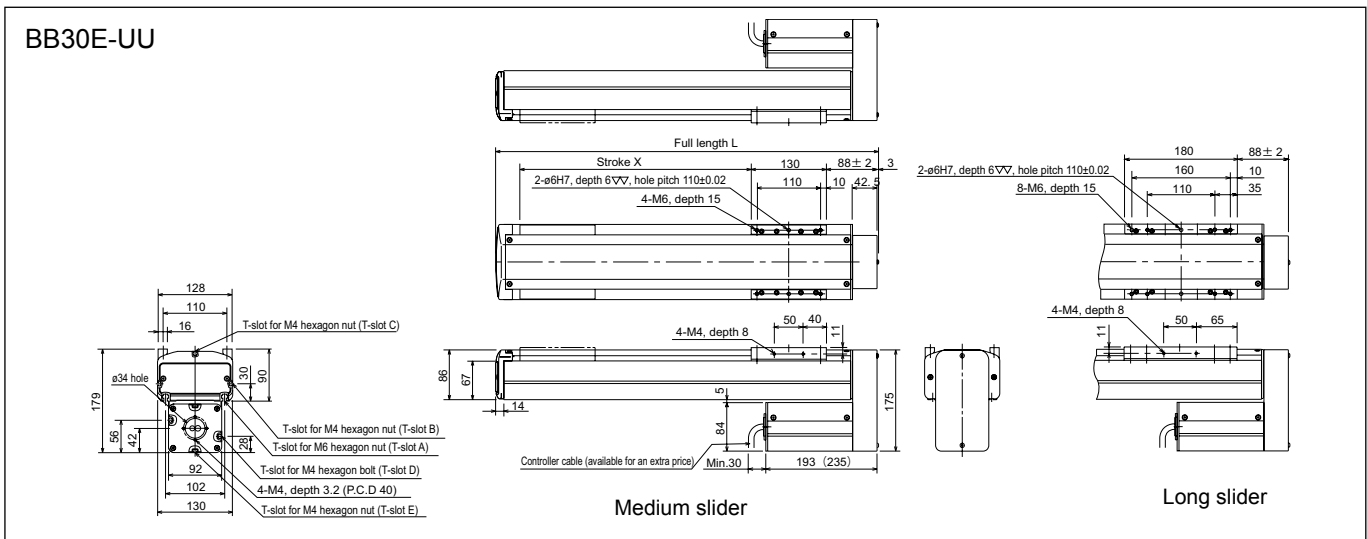
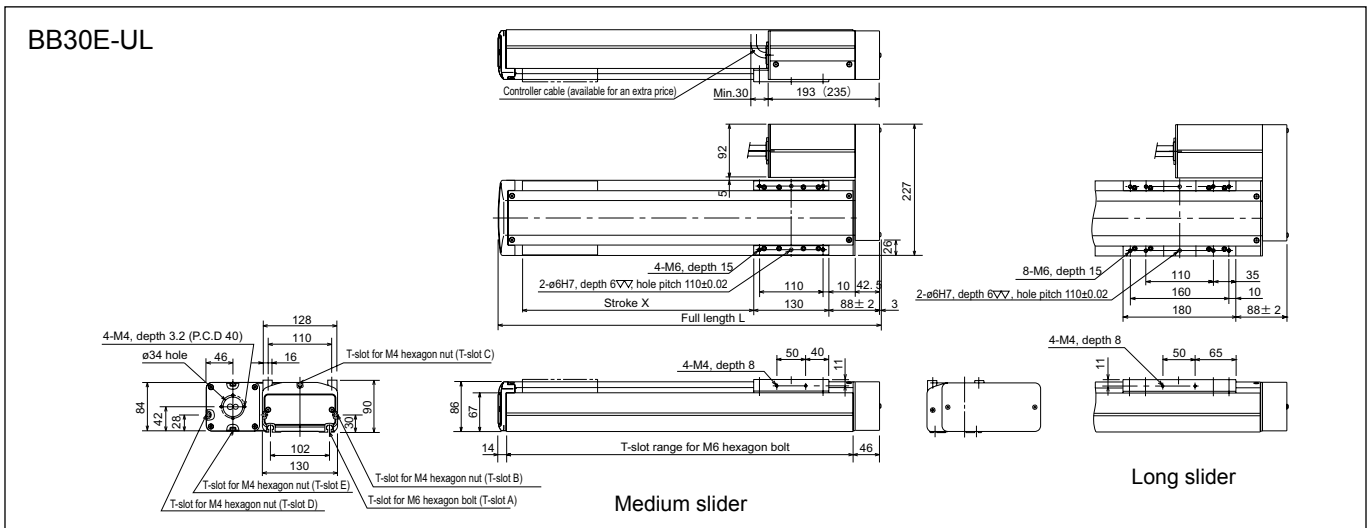
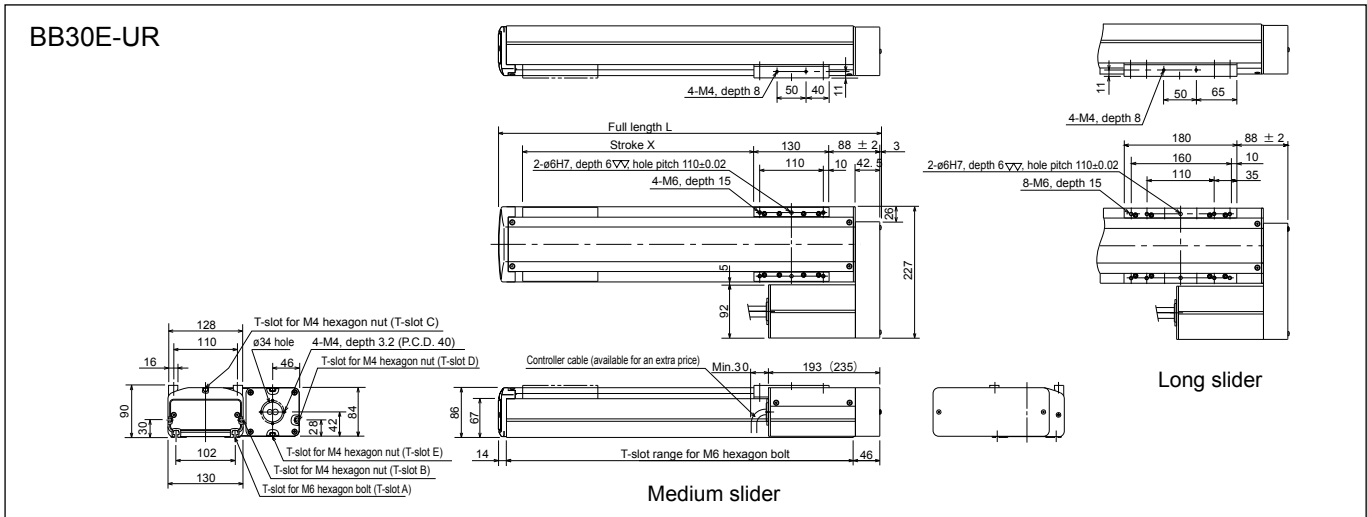

Common to BB30E-UR, UL and UU.

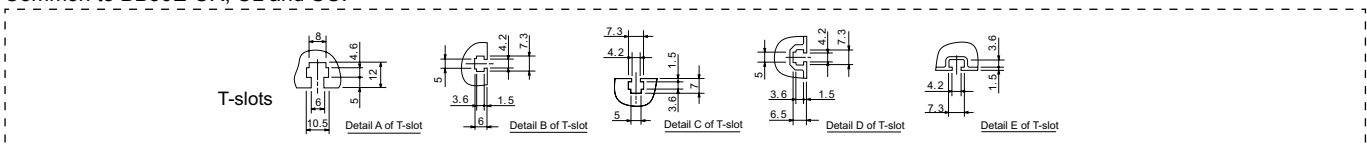

Common to BB30E-UR, UL and UU.

Medium slider	Stroke (mm)	100	200	300	400	500	600	700	800	900	1000
	Full length L (mm)	363	463	563	663	763	863	963	1063	1163	1263
	Weight (kg)	7.8(8.2)	9.0(9.4)	10.2(10.6)	11.4(11.8)	12.6(13.0)	13.8(14.2)	15.0(15.4)	16.2(16.6)	17.4(17.8)	18.6(19.0)

Common to BB30E-UR, UL and UU.

Long slider	Stroke (mm)	150	250	350	450	550	650	750	850	950
	Full length L (mm)	463	563	663	763	863	963	1063	1163	1263
	Weight (kg)	9.3(9.7)	10.5(10.9)	11.7(12.1)	12.9(13.3)	14.1(14.5)	15.3(15.7)	16.5(16.9)	17.7(18.1)	18.9(19.3)

\* Values in parentheses are for the axis with brake.

[Set designation]

**BA2 – 30F – ST – M 20 N – 40 – 1 3**

Axis structure	Type of slider	Lead	Brake	Stroke	Controller	Cable length
ST: Straight axis UR: Right side mounted motor axis UL: Left side mounted motor axis UU: Bottom side mounted motor axis	M: Medium slider L: Long slider	05 : 5mm 10 : 10mm 20 : 20mm	N : Without brake B : With brake	See "Type designation" under "Stroke" of the specifications below.	0 : None 1 : CA20 - M10 2 : CA10 - M00B 3 : CA10 - M01B	3 : 3m 9 : 9m 5 : 5m B : 11m 7 : 7m D : 13m

[Specifications]

Motor	200 W AC servo motor (absolute)				
Drive system	Ground ball screw (C7), thread outer diameter 15 mm				
Stroke (mm) (in increments of 100 mm)	Medium slider	100 ~ 600	700	800	900, 1000
	Type designation	10 ~ 60	70	80	90, A0
	Long slider	150 ~ 550	650	750	850, 950
	Type designation	15 ~ 55	65	75	85, 95
Maximum speed (mm/s) Values in <> signify the acceleration/deceleration time in seconds when the maximum Payload is loaded.	Lead 20 mm	1200<0.36>	1000<0.3>	800<0.24>	600<0.18>
	Lead 10 mm	600<0.36>	500<0.3>	400<0.24>	300<0.18>
	Lead 5 mm	300<0.36>	250<0.3>	200<0.24>	150<0.18>
Maximum Payload (kg)	Lead 20 mm	Horizontal transfer: 40 Vertical transfer: 3 (10)			
	Lead 10 mm	Horizontal transfer: 80 Vertical transfer: 8 (20)			
	Lead 5 mm	Horizontal transfer: 80 Vertical transfer: 15 (40)			
Positioning repeatability (mm)	±0.01				
Resolution (mm)	0.01				
Allowable static load moment (N·m)	Medium slider MR: 510, MP: 430, MY: 370 Long slider MR: 510, MP: 750, MY: 650				
Brake	Braking while not excited, voltage DC24 V				
Master controller	Select from CA20-M10, CA10-M00B and CA10-M01B.				

- Notes: \* When using the axis as a vertical axis, select the type with brake.  
 \* The maximum Payload signifies a load exerted on top of the slider. Also refer to the dynamic load moment given in pages 220 to 227.  
 \* The values in parentheses under "Maximum Payload" are applicable when a regeneration discharge unit (ABSU-2000) is equipped.  
 \* The acceleration/deceleration time represents the time until the axis reaches a programmed speed.

Ball-screw driven

[Axis designation]

**BB30F – ST – M 20 N – 40**

Axis structure	Type of slider	Lead	Brake	Stroke
ST: Straight axis UR: Right side mounted motor axis UL: Left side mounted motor axis UU: Bottom side mounted motor axis	M: Medium slider L: Long slider	05 : 5mm 10 : 10mm 20 : 20mm	N : Without brake B : With brake	See "Type designation" under "Stroke" of the specifications.

[Dimensions]

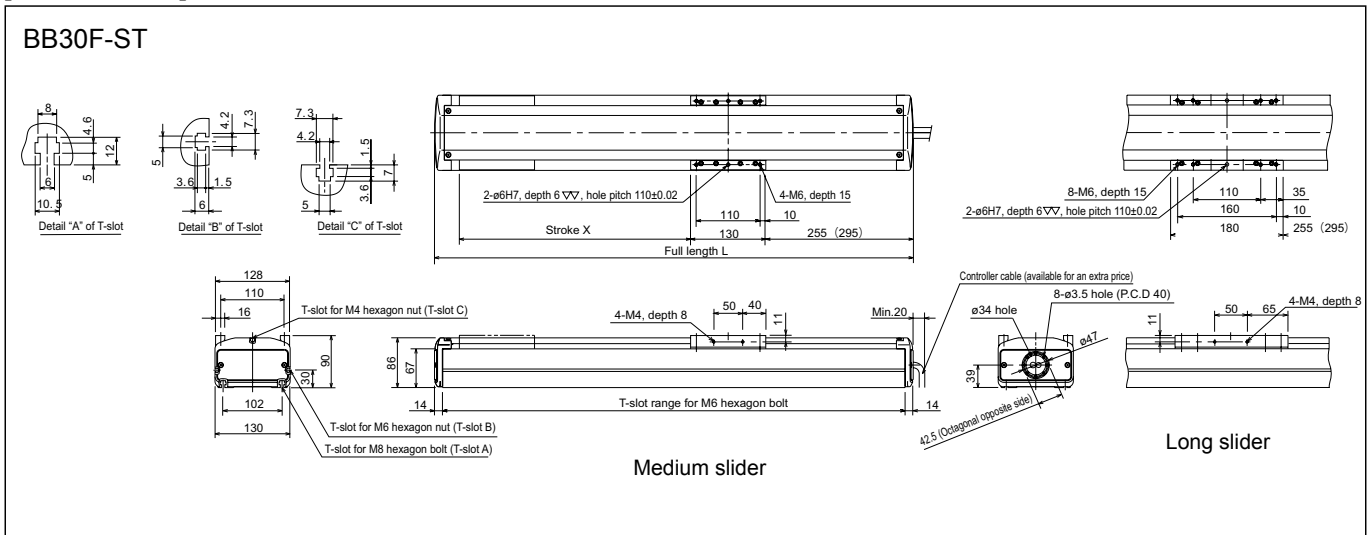

Medium slider	Stroke (mm)	100	200	300	400	500	600	700	800	900	1000
	Full length L (mm)	528(568)	628(668)	728(768)	828(868)	928(968)	1028(1068)	1128(1168)	1228(1268)	1328(1368)	1428(1468)
	Weight (kg)	9.6(10.2)	10.8(11.4)	12.0(12.6)	13.2(13.8)	14.4(15.0)	15.6(16.2)	16.8(17.4)	18.0(18.6)	19.2(19.8)	20.4(21.0)

Long slider	Stroke (mm)	150	250	350	450	550	650	750	850	950
	Full length L (mm)	628(668)	728(768)	828(868)	928(968)	1028(1068)	1128(1168)	1228(1268)	1328(1368)	1428(1468)
	Weight (kg)	11.1(11.7)	12.3(12.9)	13.5(14.1)	14.7(15.3)	15.9(16.5)	17.1(17.7)	18.3(18.9)	19.5(20.1)	20.7(21.3)

\* Values in parentheses are for the axis with brake.

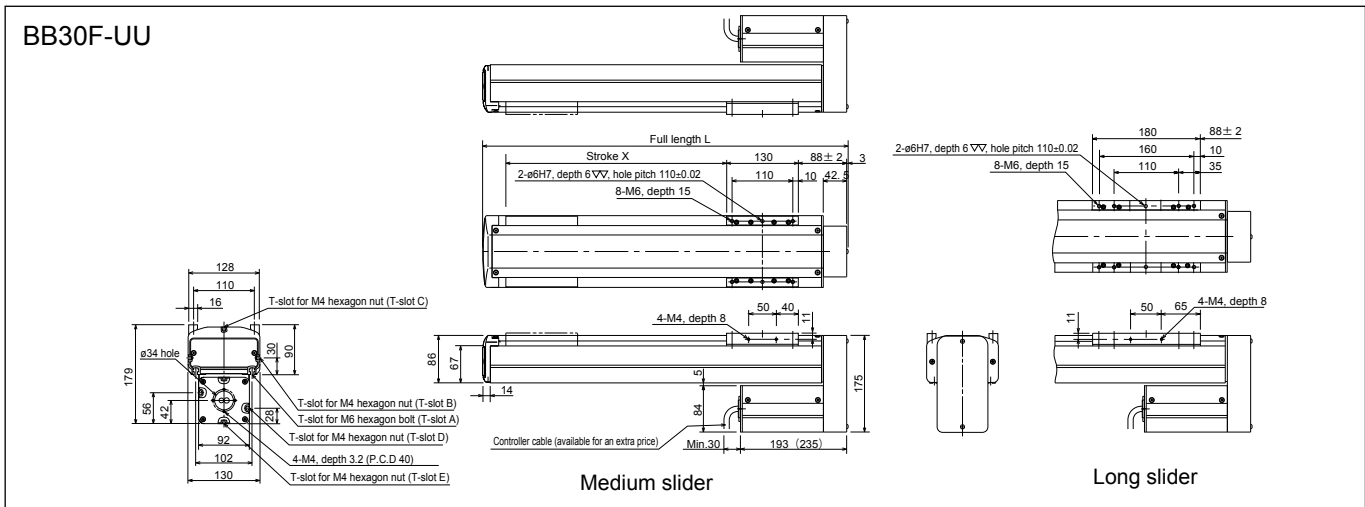
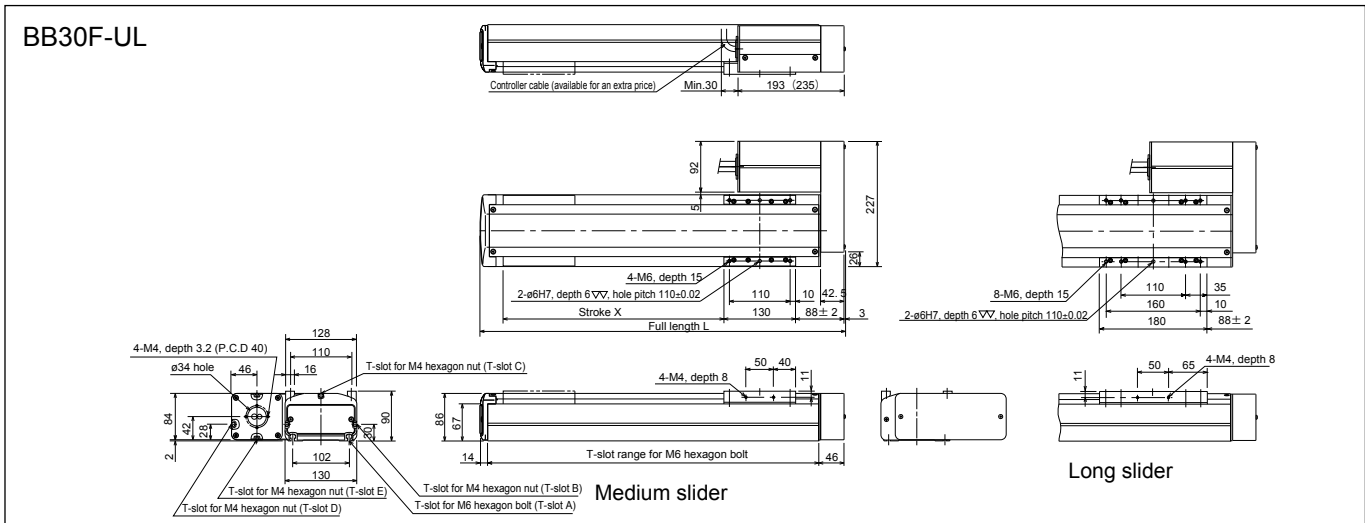
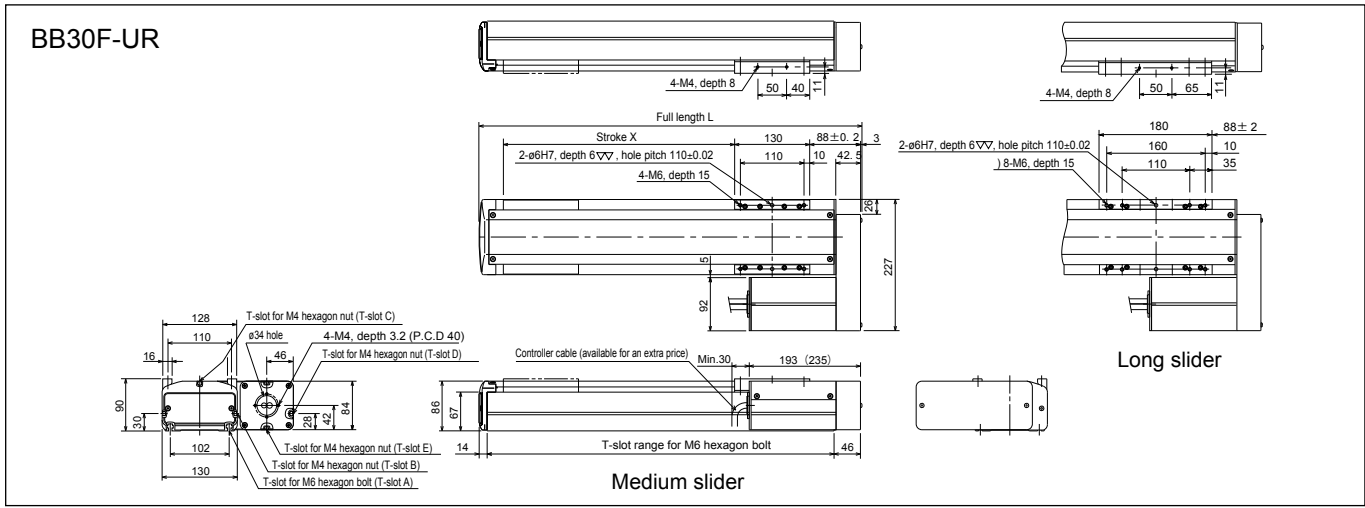

Common to BB30F-UR, UL and UU.

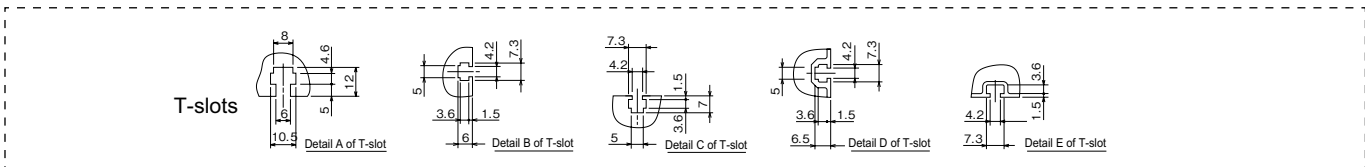

Common to BB30F-UR, UL and UU.

Medium slider	Stroke (mm)	100	200	300	400	500	600	700	800	900	1000
	Full length L (mm)	363	463	563	663	763	863	963	1063	1163	1263
	Weight (kg)	8.5(9.1)	9.7(10.3)	10.9(11.5)	12.1(12.7)	13.3(13.9)	14.5(15.1)	15.7(16.3)	16.9(17.5)	18.1(18.7)	19.3(19.9)

Common to BB50F-UR, UL and UU.

Long slider	Stroke (mm)	150	250	350	450	550	650	750	850	950
	Full length L (mm)	463	563	663	763	863	963	1063	1163	1263
	Weight (kg)	10.0(10.6)	11.2(11.8)	12.4(13.0)	13.6(14.2)	14.8(15.4)	16.0(16.6)	17.2(17.8)	18.4(19.0)	19.6(20.2)

\* Values in parentheses are for the axis with brake.

[Set designation]

**BA2 – 50F – ST – M 20 N – 40 – 1 3**

<b>Axis structure</b> ST: Straight axis UR: Right side mounted motor axis UL: Left side mounted motor axis UU: Bottom side mounted motor axis	<b>Type of slider</b> M: Medium slider L: Long slider	<b>Lead</b> 05 : 5mm 10 : 10mm 20 : 20mm	<b>Brake</b> N : Without brake B : With brake	<b>Stroke</b> See "Type designation" under "Stroke" of the specifications below.	<b>Controller</b> 0 : None 1 : CA20 - M10 2 : CA10 - M00B 3 : CA10 - M01B	<b>Cable length</b> 3 : 3m 9 : 9m 5 : 5m B : 11m 7 : 7m D : 13m
---	---	---	---	---	---	--

[Specifications]

Motor	200 W AC servo motor (absolute)							
Drive system	Ground ball screw (C7), thread outer diameter 20 mm							
Stroke (mm) (in increments of 100 mm)	Medium slider	200 ~ 600	700, 800	900, 1000	1100, 1200	1300	1400	1500
	Type designation	20 ~ 60	70, 80	90, A0	B0, C0	D0	E0	F0
	Long slider	250 ~ 550	650, 750	850, 950	1050, 1150	1250	1350	1450
	Type designation	25 ~ 55	65, 75	85, 95	A5, B5	C5	D5	E5
Maximum speed (mm/s) Values in <> signify the acceleration/deceleration time in seconds when the maximum Payload is loaded.	Lead 20 mm	1200<0.36>	1100<0.33>	1000<0.3>	700<0.21>	500<0.15>	400<0.12>	300<0.1>
	Lead 10 mm	600<0.36>	550<0.33>	500<0.3>	350<0.21>	250<0.15>	200<0.12>	150<0.1>
	Lead 5 mm	300<0.36>	280<0.33>	250<0.3>	180<0.21>	130<0.15>	100<0.12>	80<0.1>
Maximum Payload (kg)	Lead 20 mm	Horizontal transfer: 60 (Note 1) Vertical transfer: 3 (12) (Note 2)						
	Lead 10 mm	Horizontal transfer: 100 Vertical transfer: 8 (25)						
	Lead 5 mm	Horizontal transfer: 100 Vertical transfer: 15 (50)						
Positioning repeatability (mm)	±0.01							
Resolution (mm)	0.01							
Allowable static load moment (N-m)	Medium slider MR: 2080, MP: 2160, MY: 1820 Long slider MR: 2080, MP: 3150, MY: 2640							
Brake	Braking while not excited, voltage DC24 V							
Master controller	Select from CA20-M10, CA10-M00B and CA10-M01B.							

- Notes:
- \* When using the axis as a vertical axis, select the type with brake.
  - \* The maximum Payload signifies a load exerted on top of the slider. Also refer to the dynamic load moment given in pages 220 to 227.
  - \* The values in parentheses under "Maximum Payload" are applicable when a regeneration discharge unit (ABSU-2000) is equipped.
  - \* The acceleration/deceleration time represents the time until the axis reaches a programmed speed.
- Note 1: When master power voltage is 110 to 120 V or 220 V to 240 V with Payload larger than 50 kg, a regeneration discharge unit (ABSU-2000) is required. When the axis speed exceeds 1,000 mm/s, allowable Payload is 50 kg.
- Note 2: When the axis speed exceeds 1,000 mm/s and a regeneration discharge unit is used, allowable Payload is 7 kg.

Ball-screw driven

[Axis designation]

**BB50F – ST – M 20 N – 40**

<b>Axis structure</b> ST: Straight axis UR: Right side mounted motor axis UL: Left side mounted motor axis UU: Bottom side mounted motor axis	<b>Type of slider</b> M: Medium slider L: Long slider	<b>Lead</b> 05 : 5mm 10 : 10mm 20 : 20mm	<b>Brake</b> N : Without brake B : With brake	<b>Stroke</b> See "Type designation" under "Stroke" of the specifications below.
---	---	---	---	---

[Dimensions]

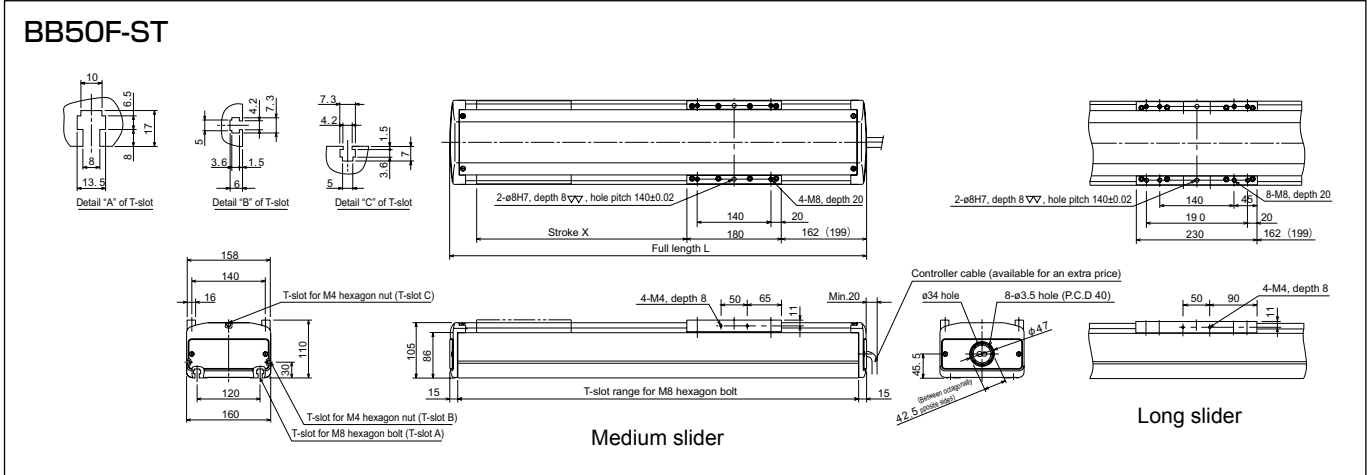

Medium slider

Stroke (mm)	200	300	400	500	600	700	800	900	1000	1100	1200	1300	1400	1500
Full length L (mm)	593(630)	693(730)	793(830)	893(930)	993(1030)	1093(1130)	1193(1230)	1293(1330)	1393(1430)	1493(1530)	1593(1630)	1693(1730)	1793(1830)	1893(1930)
Weight (kg)	16.1(16.9)	18.0(18.8)	19.9(20.7)	21.8(22.6)	23.7(24.5)	25.6(26.4)	27.5(28.3)	29.4(30.2)	31.3(32.1)	33.2(34.0)	35.1(35.9)	37.0(37.8)	38.9(39.7)	40.8(41.6)

\* Values in parentheses are for the axis with brake.

Long slider

Stroke (mm)	250	350	450	550	650	750	850	950	1050	1150	1250	1350	1450
Full length L (mm)	693(730)	793(830)	893(930)	993(1030)	1093(1130)	1193(1230)	1293(1330)	1393(1430)	1493(1530)	1593(1630)	1693(1730)	1793(1830)	1893(1930)
Weight (kg)	18.6(19.4)	20.5(21.3)	22.4(23.2)	24.3(25.1)	26.2(27.0)	28.1(28.9)	30.0(30.8)	31.9(32.7)	33.8(34.6)	35.7(36.5)	37.6(38.4)	39.5(40.3)	41.4(42.2)

\* Values in parentheses are for the axis with brake.

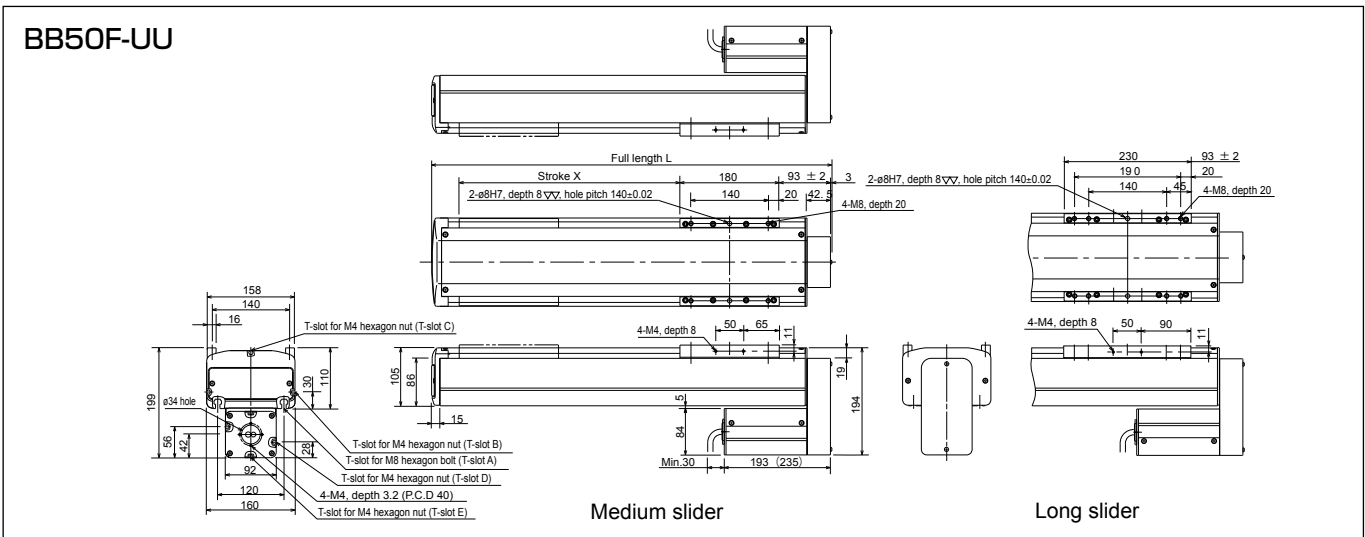
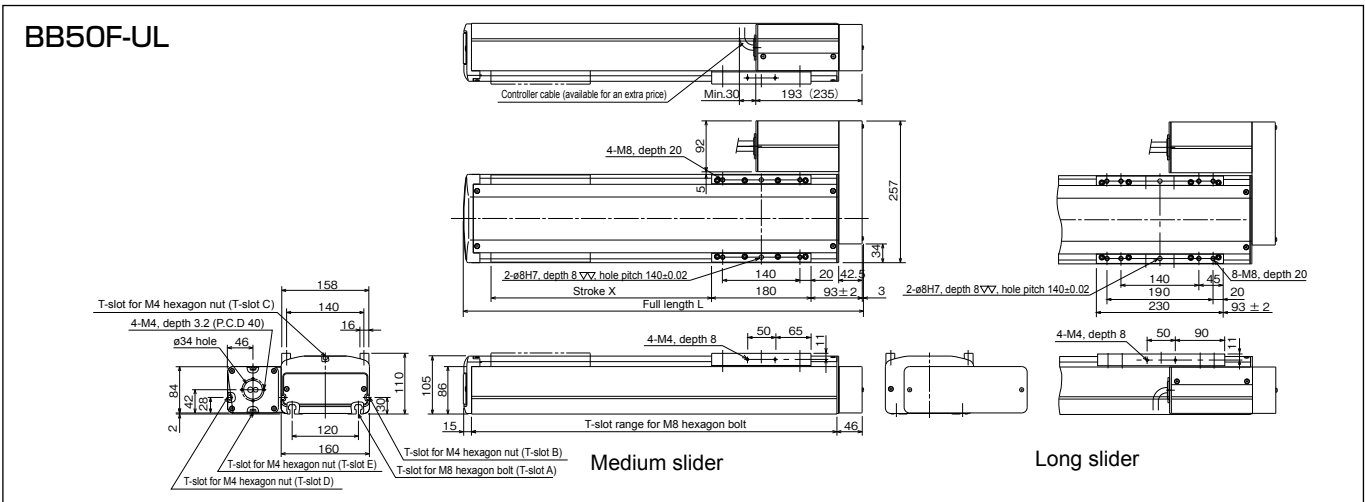
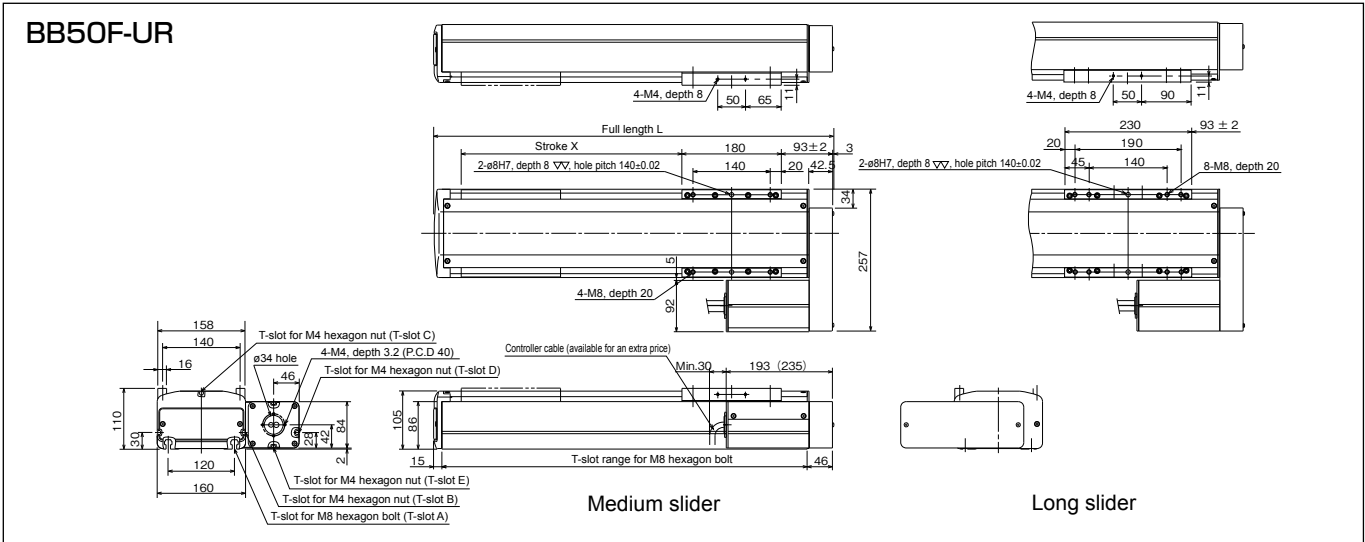

Common to BB50F-UR, UL and UU.

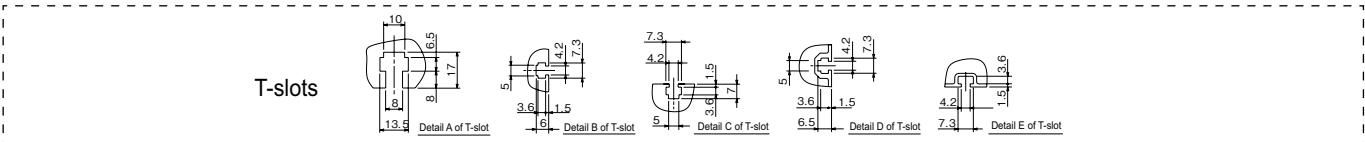

Medium slider Common to BB50F-UR, UL and UU.

Stroke (mm)	200	300	400	500	600	700	800	900	1000	1100	1200	1300	1400	1500
Full length L (mm)	526	626	726	826	926	1026	1126	1226	1326	1426	1526	1626	1726	1826
Weight (kg)	12.5(13.1)	14.4(15.0)	16.3(16.9)	18.2(18.8)	20.1(20.7)	22.0(22.6)	23.9(24.5)	25.8(26.4)	27.7(28.3)	29.6(30.2)	31.5(32.1)	33.4(34.0)	35.3(35.9)	37.2(37.8)

\* Values in parentheses are for the axis with brake.

Long slider Common to BB50F-UR, UL and UU.

Stroke (mm)	250	350	450	550	650	750	850	950	1050	1150	1250	1350	1450
Full length L (mm)	626	726	826	926	1026	1126	1226	1326	1426	1526	1626	1726	1826
Weight (kg)	15.0(15.6)	16.9(17.5)	18.8(19.4)	20.7(21.3)	22.6(23.2)	24.5(25.1)	26.4(27.0)	28.3(28.9)	30.2(30.8)	32.1(32.7)	34.0(34.6)	35.9(36.5)	37.8(38.4)

\* Values in parentheses are for the axis with brake.

[Set designation]

**BA2 – 50G – ST – M 20 N – 40 – 1 3**

Axis structure	Type of slider	Lead	Brake	Stroke	Controller	Cable length
ST: Straight axis UR: Right side mounted motor axis UL: Left side mounted motor axis UU: Bottom side mounted motor axis	M: Medium slider L: Long slider	05 : 5mm 10 : 10mm 20 : 20mm	N : Without brake B : With brake	See "Type designation" under "Stroke" of the specifications.	0 : None 1 : CA20 - M10 2 : CA10 - M00B 3 : CA10 - M01B	3 : 3m 9 : 9m 5 : 5m B : 11m 7 : 7m D : 13m

[Specifications]

Motor	400 W AC servo motor (absolute)							
Drive system	Ground ball screw (C7), thread outer diameter 20 mm							
Stroke (mm) (in increments of 100 mm)	Medium slider	200 ~ 600	700, 800	900, 1000	1100, 1200	1300	1400	1500
	Type designation	20 ~ 60	70, 80	90, A0	B0, C0	D0	E0	F0
	Long slider	250 ~ 550	650, 750	850, 950	1050, 1150	1250	1350	1450
	Type designation	25 ~ 55	65, 75	85, A95	A5, B5	C5	D5	E5
Maximum speed (mm/s) Values in < > signify the acceleration/deceleration time in seconds when the maximum Payload is loaded.	Lead 20 mm	1200<0.36>	1100<0.33>	1000<0.3>	700<0.21>	500<0.15>	400<0.12>	300<0.1>
	Lead 10 mm	600<0.36>	550<0.33>	500<0.3>	350<0.21>	250<0.15>	200<0.12>	150<0.1>
	Lead 5 mm	300<0.36>	280<0.33>	250<0.3>	180<0.21>	130<0.15>	100<0.12>	80<0.1>
Maximum Payload (kg)	Lead 20 mm	Horizontal transfer: 100 Vertical transfer: 25						
	Lead 10 mm	Horizontal transfer: 150 Vertical transfer: 50						
	Lead 5 mm	Horizontal transfer: 150 Vertical transfer: 60						
Positioning repeatability (mm)	±0.01							
Resolution (mm)	0.01							
Allowable static load moment (N·m)	Medium slider MR: 2080, MP: 2160, MY: 1820 Long slider MR: 2080, MP: 3150, MY: 2640							
Brake	Braking while not excited, voltage DC24 V							
Master controller	Select from CA20-M40, CA10-M00B and CA10-M01B.							

- Notes:
- \* When using the axis as a vertical axis, select the type with brake.
  - \* The maximum Payload signifies a load exerted on top of the slider. Also refer to the dynamic load moment given in pages 220 to 227.
  - \* The regeneration discharge unit (ABSU-4000) is required, for both horizontal and vertical transfer, regardless of payload.
  - \* The acceleration/deceleration time represents the time until the axis reaches a programmed speed.

Ball-screw driven

[Axis designation]

**BB50G – ST – M 20 N – 40**

Axis structure	Type of slider	Lead	Brake	Stroke
ST: Straight axis UR: Right side mounted motor axis UL: Left side mounted motor axis UU: Bottom side mounted motor axis	M: Medium slider L: Long slider	05 : 5mm 10 : 10mm 20 : 20mm	N : Without brake B : With brake	See "Type designation" under "Stroke" of the specifications.

[Dimensions]

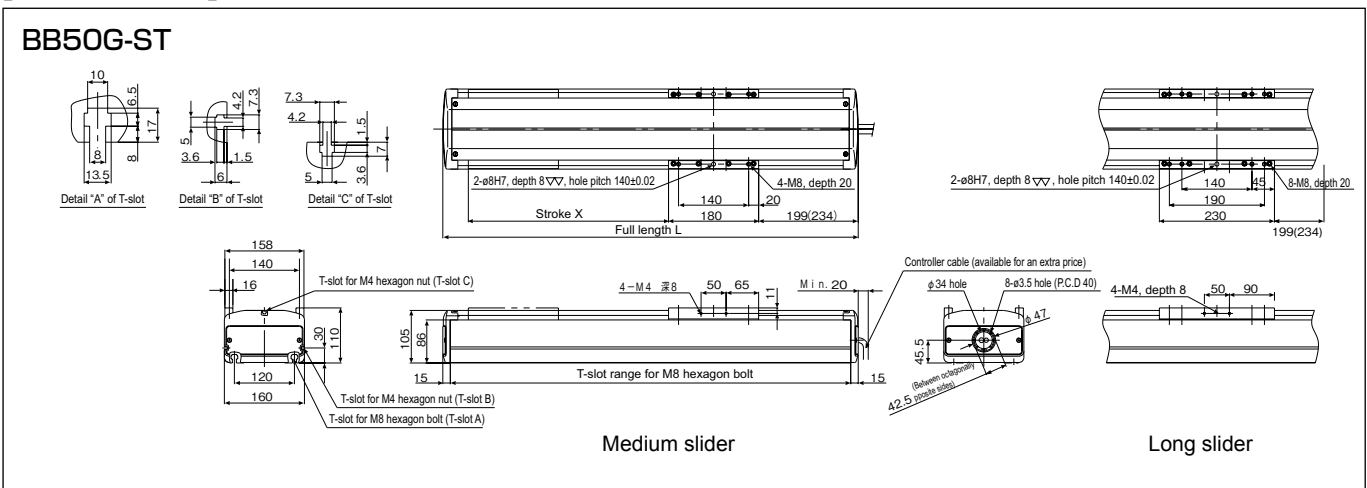

Medium slider

Stroke (mm)	200	300	400	500	600	700	800	900	1000	1100	1200	1300	1400	1500
Full length L (mm)	630(665)	730(765)	830(865)	930(965)	1030(1065)	1130(1165)	1230(1265)	1330(1365)	1430(1465)	1530(1565)	1630(1665)	1730(1765)	1830(1865)	1930(1965)
Weight (kg)	17.1(18.0)	19.0(19.9)	20.9(21.8)	22.8(23.7)	24.7(25.6)	26.6(27.5)	28.5(29.4)	30.4(31.3)	32.3(33.2)	34.2(35.1)	36.1(37.0)	38.0(38.9)	39.9(40.8)	41.8(42.7)

\* Values in parentheses are for the axis with brake.

Long slider

Stroke (mm)	250	350	450	550	650	750	850	950	1050	1150	1250	1350	1450
Full length L (mm)	730(765)	830(865)	930(965)	1030(1065)	1130(1165)	1230(1265)	1330(1365)	1430(1465)	1530(1565)	1630(1665)	1730(1765)	1830(1865)	1930(1965)
Weight (kg)	19.6(20.5)	21.5(22.4)	23.4(24.3)	25.3(26.2)	27.2(28.1)	29.1(30.0)	31.0(31.9)	32.9(33.8)	34.8(35.7)	36.7(37.6)	38.6(39.5)	40.5(41.4)	42.4(43.3)

\* Values in parentheses are for the axis with brake.



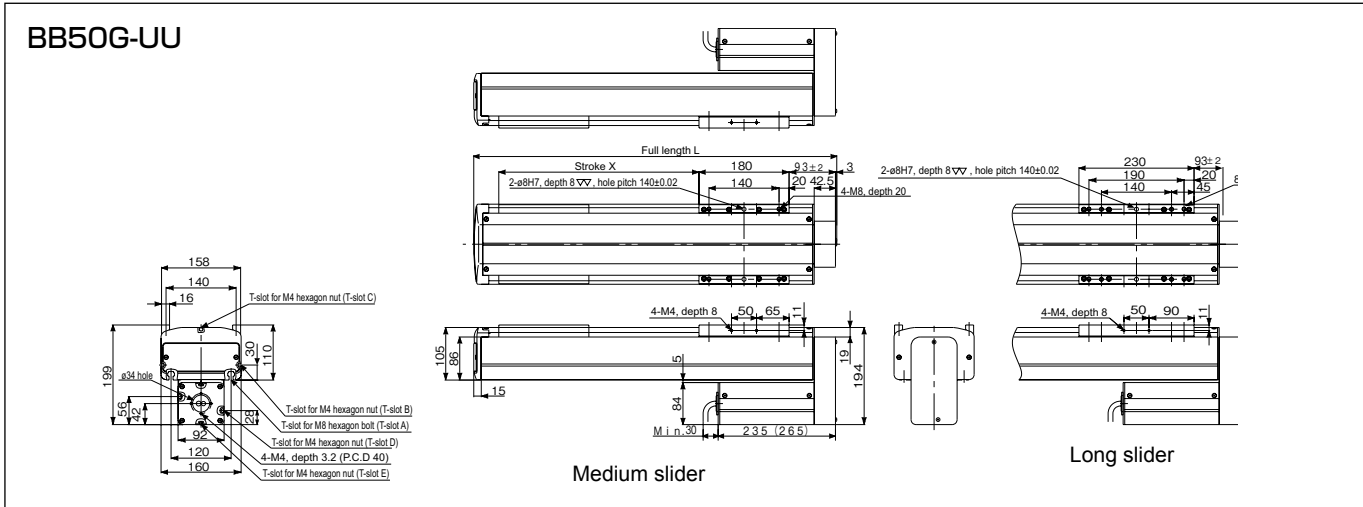
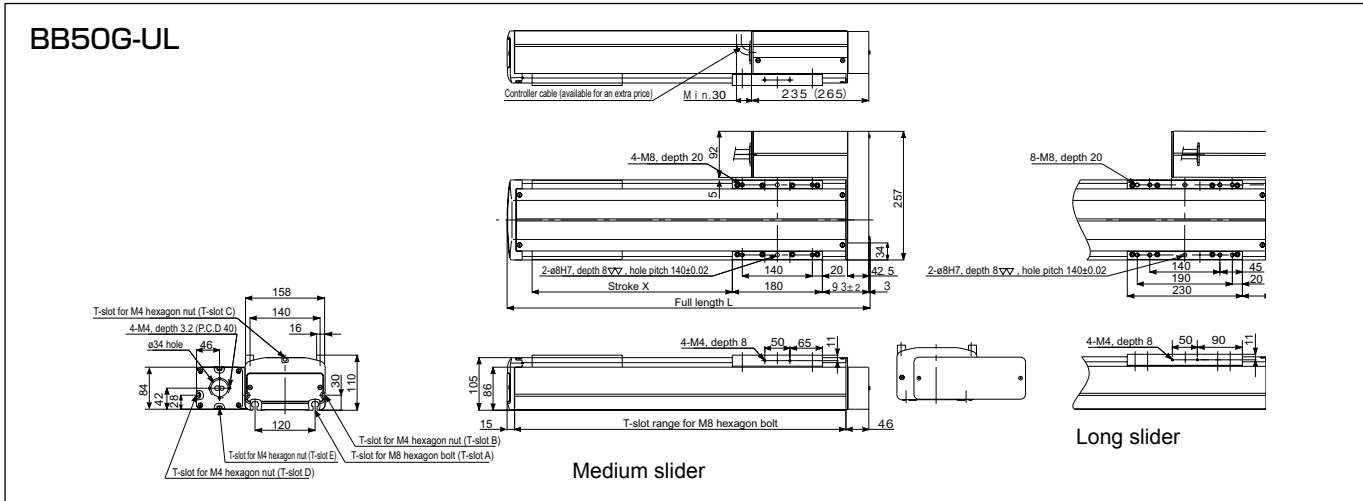
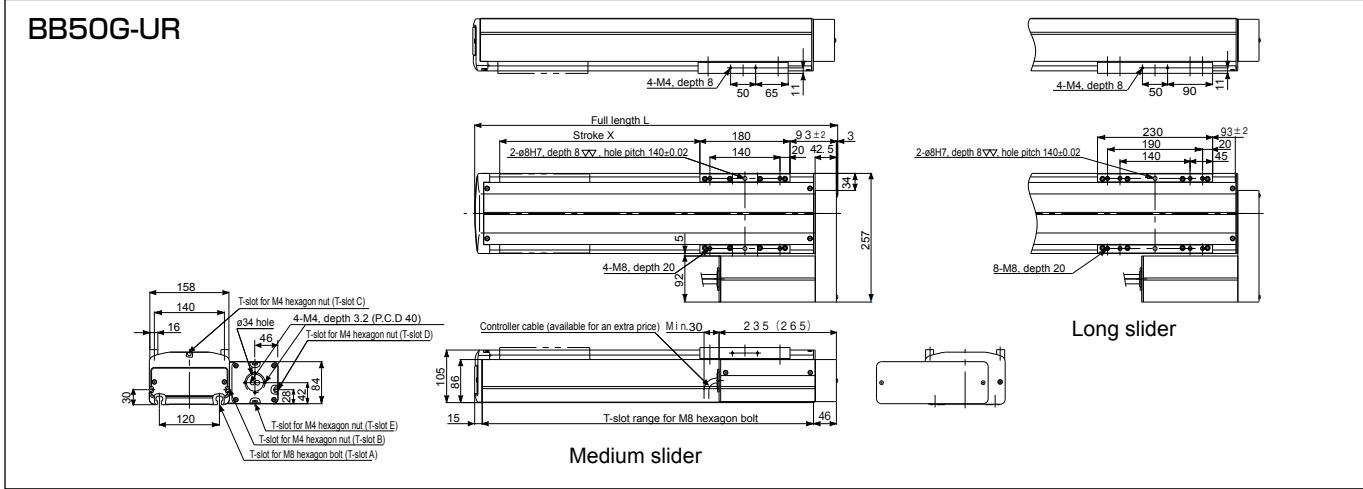

Common to BB50G-UR, UL and UU.

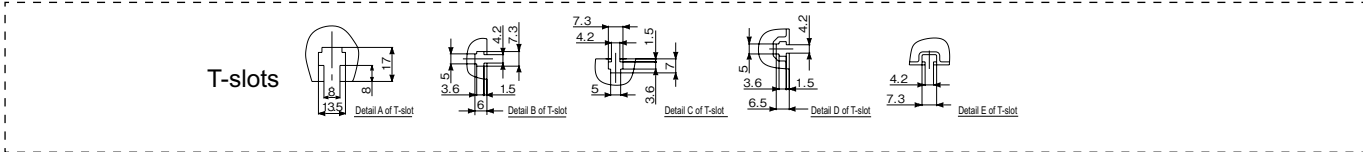

Medium slider Common to BB50G-UR, UL and UU.

Stroke (mm)	200	300	400	500	600	700	800	900	1000	1100	1200	1300	1400	1500
Full length L (mm)	526	626	726	826	926	1026	1126	1226	1326	1426	1526	1626	1726	1826
Weight (kg)	12.5(13.1)	14.4(15.0)	16.3(16.9)	18.2(18.8)	20.1(20.7)	22.0(22.6)	23.9(24.5)	25.8(26.4)	27.7(28.3)	29.6(30.2)	31.5(32.1)	33.4(34.0)	35.3(35.9)	37.2(37.8)

\* Values in parentheses are for the axis with brake.

Long slider Common to BB50G-UR, UL and UU.

Stroke (mm)	250	350	450	550	650	750	850	950	1050	1150	1250	1350	1450
Full length L (mm)	626	726	826	926	1026	1126	1226	1326	1426	1526	1626	1726	1826
Weight (kg)	15.0(15.6)	16.9(17.5)	18.8(19.4)	20.7(21.1)	22.6(23.2)	24.5(25.1)	26.4(27.0)	28.3(28.9)	30.2(30.8)	32.1(32.7)	34.0(34.6)	35.9(36.5)	37.8(38.4)

\* Values in parentheses are for the axis with brake.

[Set designation]  
Long stroke axis

**BA2 – 50F – LT – M 20 N – R0 – 1 3**

Type of slider M: Medium slider L: Long slider	Lead 20 : 20mm	Brake N : Without brake	Stroke See "Type designation" under "Stroke" of the specifications.	Controller 0 : None 1 : CA20 - M10 2 : CA10 - M00B 3 : CA10 - M01B	Cable length 3 : 3m 9 : 9m 5 : 5m B : 11m 7 : 7m D : 13m
--	-------------------	----------------------------	--	--	---

[Specifications]

Ordered product: Confirm the delivery from us at every order entry.

Motor	200 W AC servo motor (absolute)															
Drive system	Ball screw (nut rotation type), thread outer diameter 20 mm															
Stroke (mm) (in increments of 100 mm)	Medium slider	1100	1200	1300	1400	1500	1600	1700	1800	1900	2000	2100	2200	2300	2400	2500
	Type designation	B0	C0	D0	E0	F0	G0	H0	J0	K0	L0	M0	N0	P0	Q0	R0
	Long slider	1150	1250	1350	1450	1550	1650	1750	1850	1950	2050	2150	2250	2350	2450	
	Type designation	B5	C5	D5	E5	F5	G5	H5	J5	K5	L5	M5	N5	P5	Q5	
Maximum speed (mm/s)	Lead 20 mm	1000														
Maximum Payload (kg) Acceleration/deceleration time: 0.6 sec.	Horizontal transfer: 60															
Positioning repeatability (mm)	±0.05															
Resolution (mm)	0.01															
Allowable static load moment (N·m)	Medium slider MR: 2080, MP: 2160, MY: 1820 Long slider MR: 2080, MP: 3150, MY: 2640															
Master controller	Select from CA20-M10, CA10-M00B and CA10-M01B.															

- Notes:
- \* The maximum Payload signifies a load exerted on top of the slider. Also refer to the dynamic load moment given in pages 220 to 227.
  - \* For the 200 W type, when master power voltage is 110 V to 120 V or 220 V to 240 V with Payload larger than 50 kg, a regeneration discharge unit (ABSU-2000) is required.
  - \* The acceleration/deceleration time represents the time until the axis reaches a programmed speed.

Ball-screw driven

[Set designation]

**BB50F – LT – M 20 N – R0**

Type of slider M: Medium slider L: Long slider	Lead 20 : 20mm	Brake N : Without brake	Stroke See "Type designation" under "Stroke" of the specifications.
--	-------------------	----------------------------	--

**BB50F-LT**

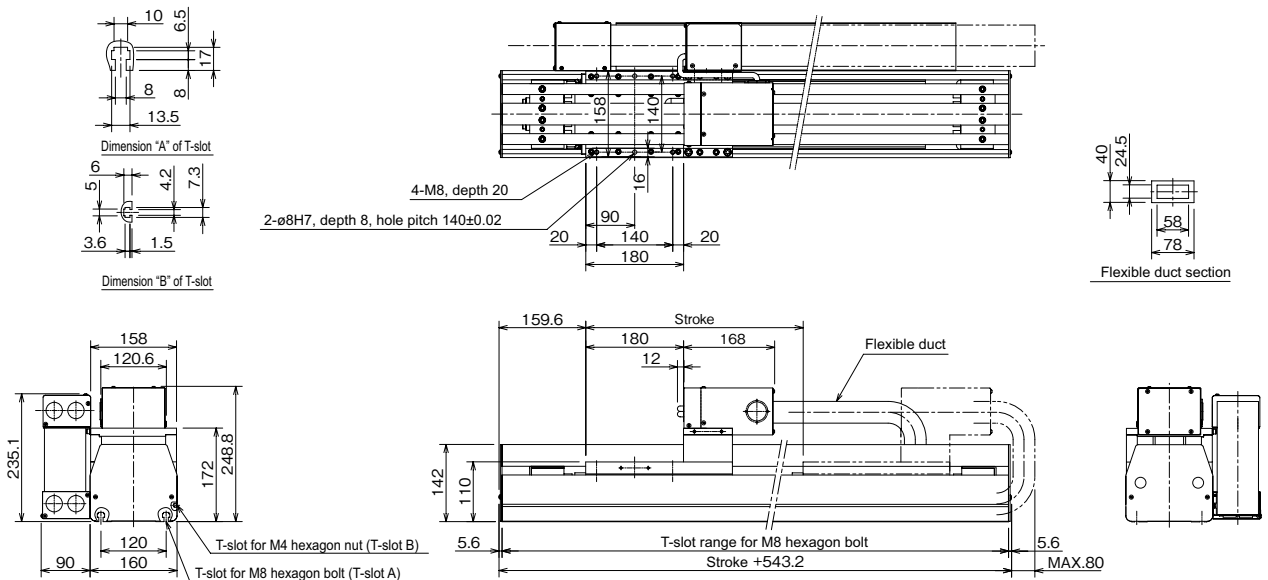

[Set designation]  
Long stroke axis

**BA2 – 50G – LT – M 20 N – RO – 1 3**

Type of slider M: Medium slider L: Long slider	Lead 20 : 20mm	Brake N : Without brake	Stroke See "Type designation" under "Stroke" of the specifications.	Controller 0 : None 1 : CA20 - M10 2 : CA10 - M00B 3 : CA10 - M01B	Cable length 3 : 3m 9 : 9m 5 : 5m B : 11m 7 : 7m D : 13m
--	-------------------	----------------------------	--	--	---

[Specifications]

Ordered product: Confirm the delivery from us at every order entry.

Motor	400 W AC servo motor (absolute)															
Drive system	Ball screw (nut rotation type), thread outer diameter 20 mm															
Stroke (mm) (in increments of 100 mm)	Medium slider	1100	1200	1300	1400	1500	1600	1700	1800	1900	2000	2100	2200	2300	2400	2500
	Type designation	B0	C0	D0	E0	F0	G0	H0	J0	K0	L0	M0	N0	P0	Q0	R0
	Long slider	1150	1250	1350	1450	1550	1650	1750	1850	1950	2050	2150	2250	2350	2450	
	Type designation	B5	C5	D5	E5	F5	G5	H5	J5	K5	L5	M5	N5	P5	Q5	
Maximum speed (mm/s)	Lead 20 mm	1000														
Maximum Payload (kg) Acceleration/deceleration time: 0.3 sec.	Horizontal transfer: 100															
Positioning repeatability (mm)	±0.05															
Resolution (mm)	0.01															
Allowable static load moment (N-m)	Medium slider MR: 2080, MP: 2160, MY: 1820 Long slider MR: 2080, MP: 3150, MY: 2640															
Master controller	Select from CA20-M40, CA10-M00B and CA10 - M01B.															

- Notes: \* The maximum Payload signifies a load exerted on top of the slider. Also refer to the dynamic load moment given in pages 220 to 227.  
 \* For the 400 W type, a regeneration discharge unit (ABSU-4000) is required, irrespective of Payload.  
 \* The acceleration/deceleration time represents the time until the axis reaches a programmed speed.

[Axis designation]

**BB50G – LT – M 20 N – RO**

Type of slider M: Medium slider L: Long slider	Lead 20 : 20mm	Brake N : Without brake	Stroke See "Type designation" under "Stroke" of the specifications.
--	-------------------	----------------------------	--

Ball-screw driven

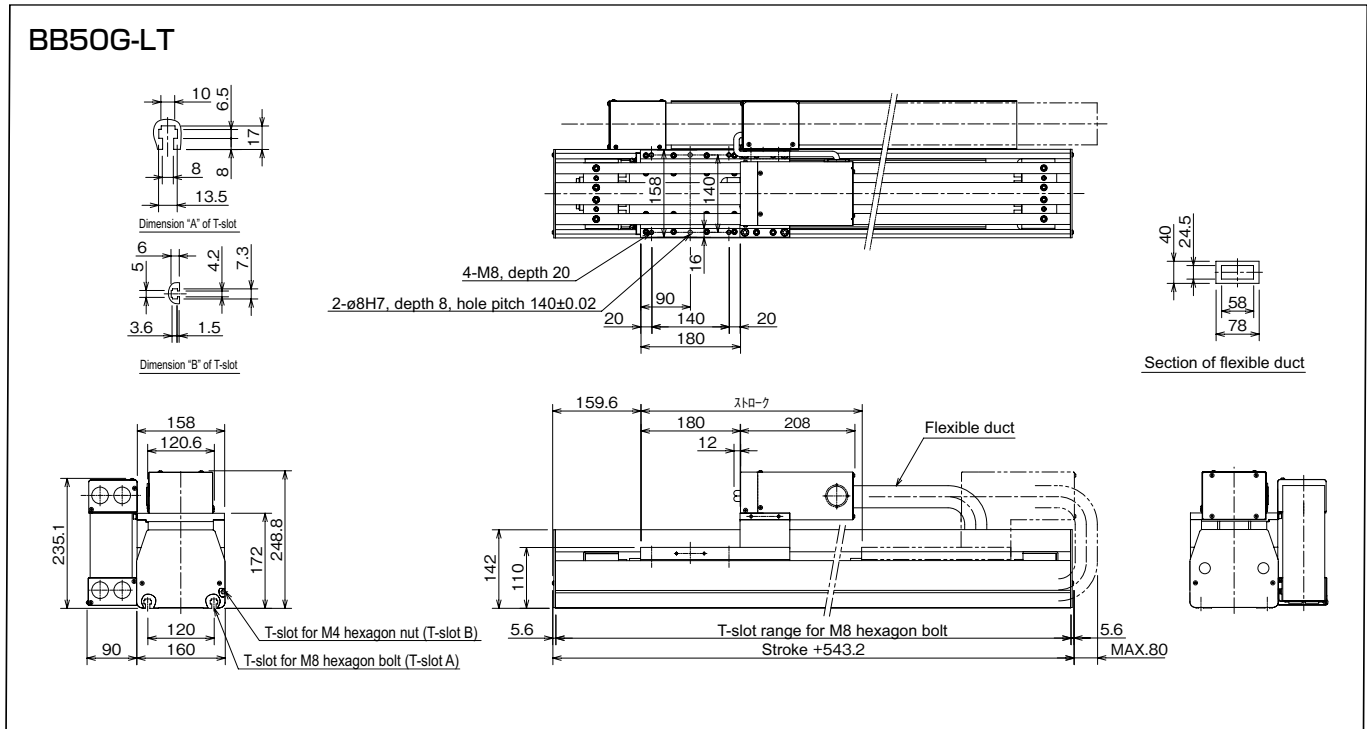

[Set designation]

**BA2 - 10E - BT - M 21 N - 40 - 1 3**

Motor set direction BT: Facing up BR: Facing right BL: Facing left BU: Facing down	Type of slider S: Short slider M: Medium slider	Lead 21 : 21mm	Brake N : Without brake	Stroke See "Type designation" under "Stroke" of the specifications.	Controller 0 : None 1 : CA20 - M10 2 : CA10 - M00B 3 : CA10 - M01B	Cable length 3 : 3m 9 : 9m 5 : 5m B : 11m 7 : 7m D : 13m
--	---	-------------------	----------------------------	--	--	---

[Specifications]

Motor	100 W AC servo motor (absolute)										
Drive system	Timing belt										
Lead, converted into ball screw (mm)	21										
Stroke (mm) (in increments of 100 mm)	Short slider	150 ~ 950	1050	1150	1250	1350	1450	1550	1650	1750	1850
	Type designation	15 ~ 95	A 5	B 5	C 5	D 5	E 5	F 5	G 5	H 5	J 5
	Medium slider	100 ~ 900	1000	1100	1200	1300	1400	1500	1600	1700	1800
	Type designation	10 ~ 90	A 0	B 0	C 0	D 0	E 0	F 0	G 0	H 0	J 0
Maximum speed (mm/s)	1000										
Maximum Payload (kg) Acceleration/deceleration time: 0.3 sec. or over	Horizontal transfer: 15										
Positioning repeatability (mm)	±0. 05										
Resolution (mm)	0. 01										
Allowable static load moment (N·m)	Short slider MR: 49, MP: 14, MY: 13 Medium slider MR: 59, MP: 59, MY: 54										
Master controller	Select from CA20-M10, CA10-M00B and CA10-M01B.										

Notes: \* The maximum Payload signifies a load exerted on top of the slider. Also refer to the dynamic load moment given in pages 220 to 227.  
\* The acceleration/deceleration time represents the time until the axis reaches a programmed speed.

Timing Belt Driven

[Axis designation]

**BB10E - BT - M 21 N - 40**

Motor set direction BT: Facing up BR: Facing right BL: Facing left BU: Facing down	Type of slider S: Short slider M: Medium slider	Lead 21 : 21mm	Brake N : Without brake	Stroke See "Type designation" under "Stroke" of the specifications.
--	---	-------------------	----------------------------	--

[Dimensions]

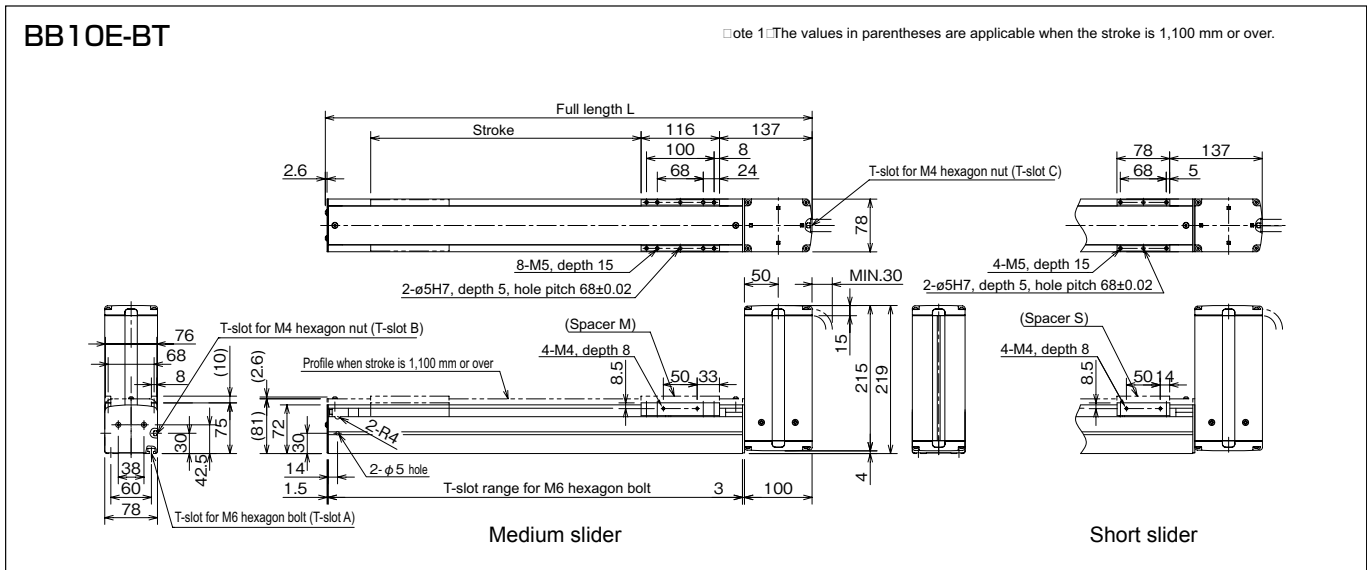

BB10E-BR

Note 1: The values in parentheses are applicable when the stroke is 1,100 mm or over.

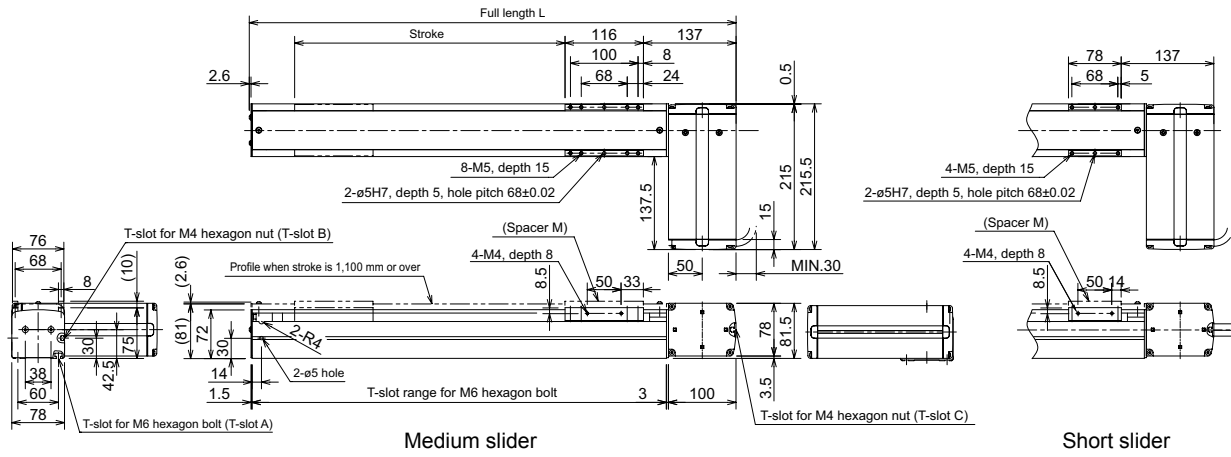

BB10E-BL

Note 1: The values in parentheses are applicable when the stroke is 1,100 mm or over.

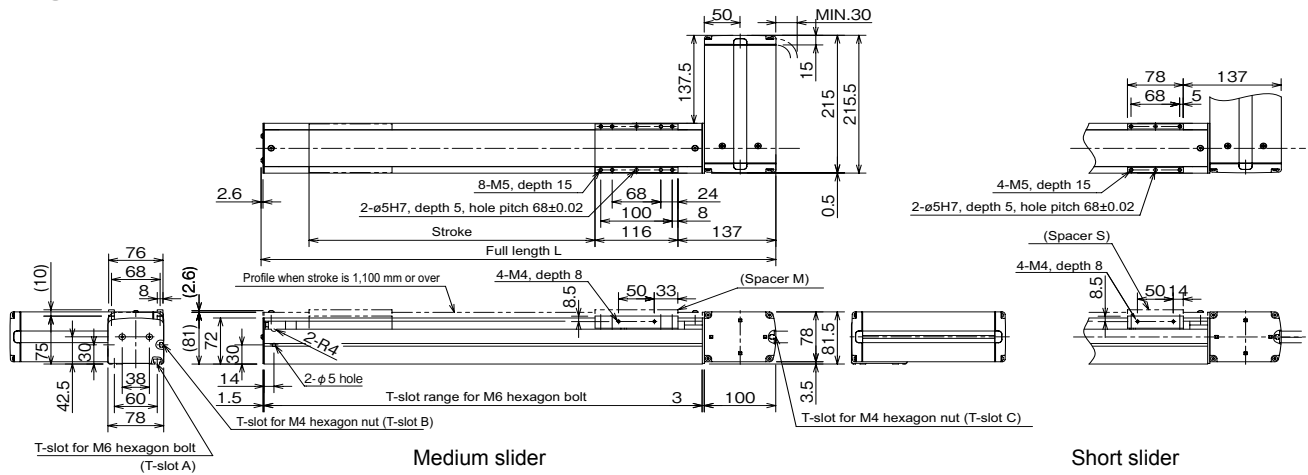

BB10E-BU

Note 1: The values in parentheses are applicable when the stroke is 1,100 mm or over.

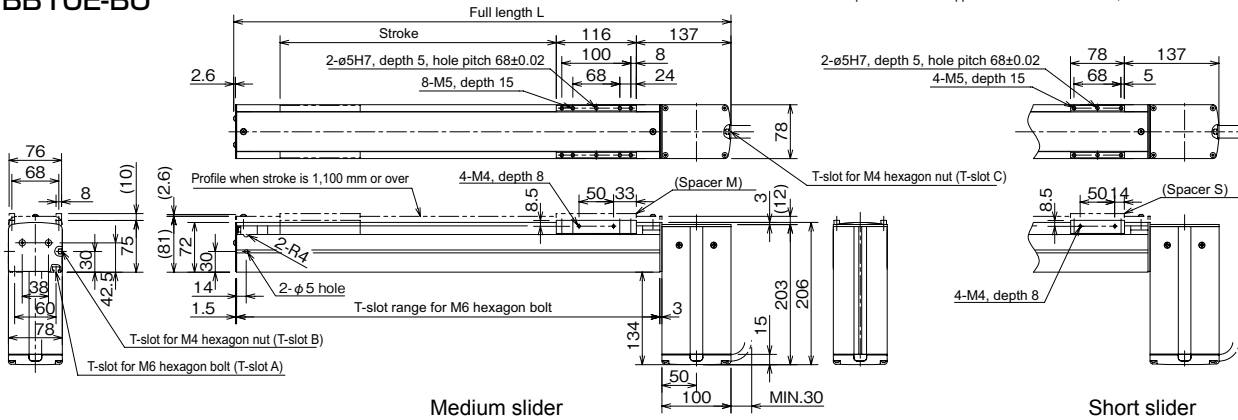

Common to BB10E-BT, BR, BL and BU.

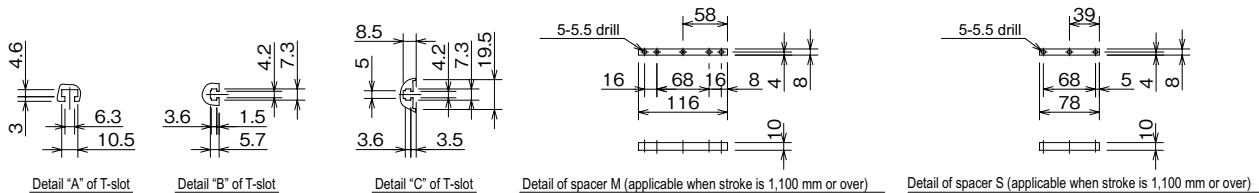

Medium slider Common to BB10E-BT, BR, BL and BU.

Stroke (mm)	100	200	300	400	500	600	700	800	900	1000	1100	1200	1300	1400	1500	1600	1700	1800
Full length L (mm)	420.1	520.1	620.1	720.1	820.1	920.1	1020.1	1120.1	1220.1	1320.1	1420.1	1520.1	1620.1	1720.1	1820.1	1920.1	2020.1	2120.1
Weight (kg)	5.0	5.6	6.2	6.8	7.4	8.0	8.6	9.2	9.8	10.4	11.0	11.6	12.2	12.8	13.4	14.0	14.6	15.2

Short slider Common to BB10E-BT, BR, BL and BU.

Stroke (mm)	150	250	350	450	550	650	750	850	950	1050	1150	1250	1350	1450	1550	1650	1750	1850
Full length L (mm)	420.1	520.1	620.1	720.1	820.1	920.1	1020.1	1120.1	1220.1	1320.1	1420.1	1520.1	1620.1	1720.1	1820.1	1920.1	2020.1	2120.1
Weight (kg)	4.7	5.3	5.9	6.5	7.1	7.7	8.3	8.9	9.5	10.1	10.7	11.3	11.9	12.5	13.1	13.7	14.3	14.9

[Set designation]

**BA2 - 10F - BT - M 21 N - 40 - 1 3**

Motor set direction	Type of slider	Lead	Brake	Stroke	Controller	Cable length
BT: Facing up BR: Facing right BL: Facing left BU: Facing down	S: Short slider M: Medium slider	21: 21mm 42: 42mm	N: Without brake	See "Type designation" under "Stroke" of the specifications.	0: None 1: CA20 - M10 2: CA10 - M00B 3: CA10 - M01B	3: 3m 9: 9m 5: 5m B: 11m 7: 7m D: 13m

[Specifications]

Motor	200 W AC servo motor (absolute)										
Drive system	Timing belt										
Lead, converted into ball screw (mm)	21, 42										
Stroke (mm) (in increments of 100 mm)	Short slider	150 ~ 950	1050	1150	1250	1350	1450	1550	1650	1750	1850
	Type designation	15 ~ 95	A 5	B 5	C 5	D 5	E 5	F 5	G 5	H 5	J 5
	Medium slider	100 ~ 900	1000	1100	1200	1300	1400	1500	1600	1700	1800
	Type designation	10 ~ 90	A 0	B 0	C 0	D 0	E 0	F 0	G 0	H 0	J 0
Maximum speed (mm/s)	Lead 21	1000									
	Lead 42	2000									
Maximum Payload (kg)	Lead 21	Horizontal transfer: 20, acceleration/deceleration time: 0.3 sec. or ove									
	Lead 42	Horizontal transfer: 10, acceleration/deceleration time: 0.5 sec. or over									
Positioning repeatability (mm)	±0.05										
Resolution (mm)	0.01										
Allowable static load moment (N·m)	Short slider MR: 49, MP: 14, MY: 13 Medium slider MR: 59, MP: 59, MY: 54										
Master controller	Select from CA20-M10, CA10-M00B and CA10-M01B.										

Notes: \* The maximum Payload signifies a load exerted on top of the slider. Also refer to the dynamic load moment given in pages 220 to 227.  
\* The acceleration/deceleration time represents the time until the axis reaches a programmed speed.

[Axis designation]

**BB10F - BT - M 21 N - 40**

Motor set direction	Type of slider	Lead	Brake	Stroke
BT: Facing up BR: Facing right BL: Facing left BU: Facing down	S: Short slider M: Medium slider	21: 21mm 42: 42mm	N: Without brake	See "Type designation" under "Stroke" of the specifications.

Timing Belt Driven

[Dimensions]

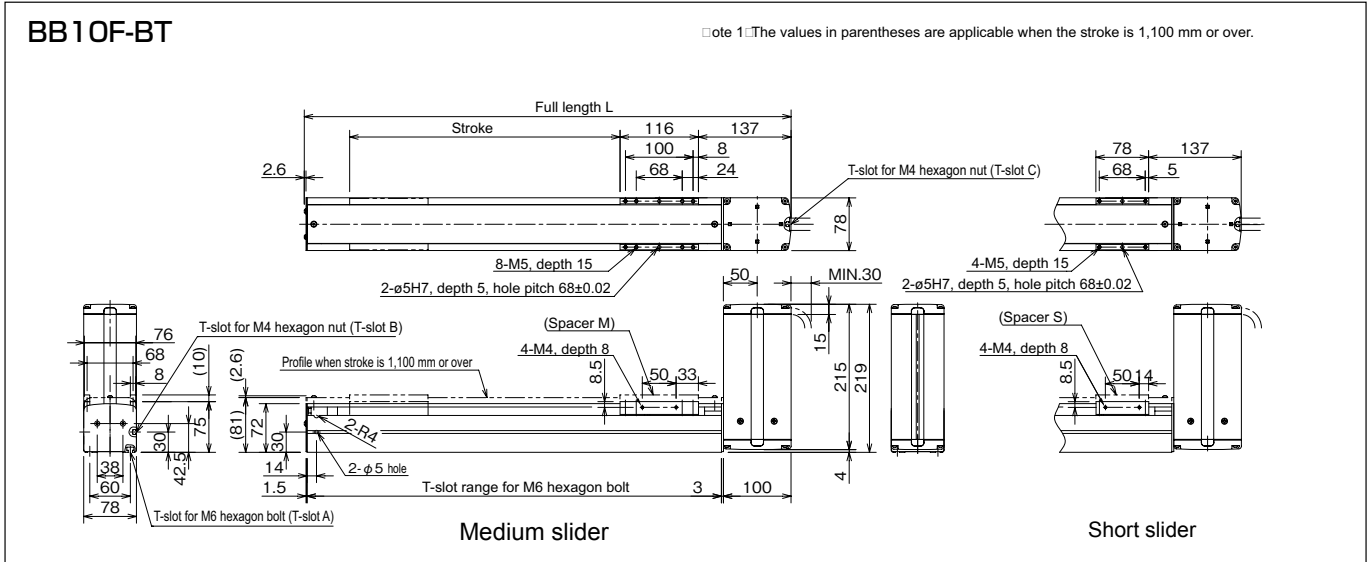

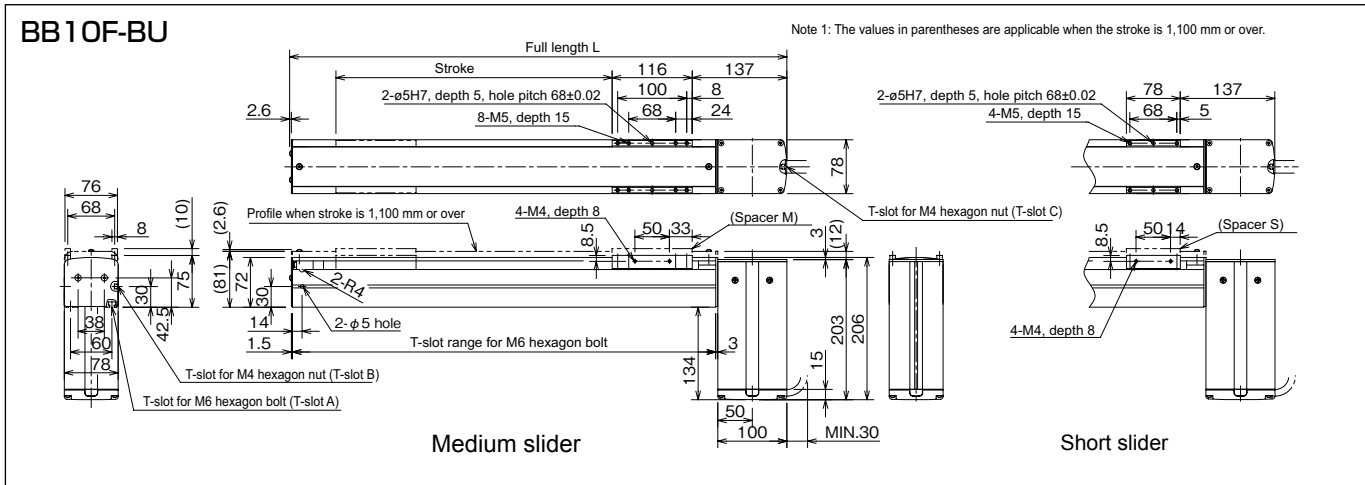
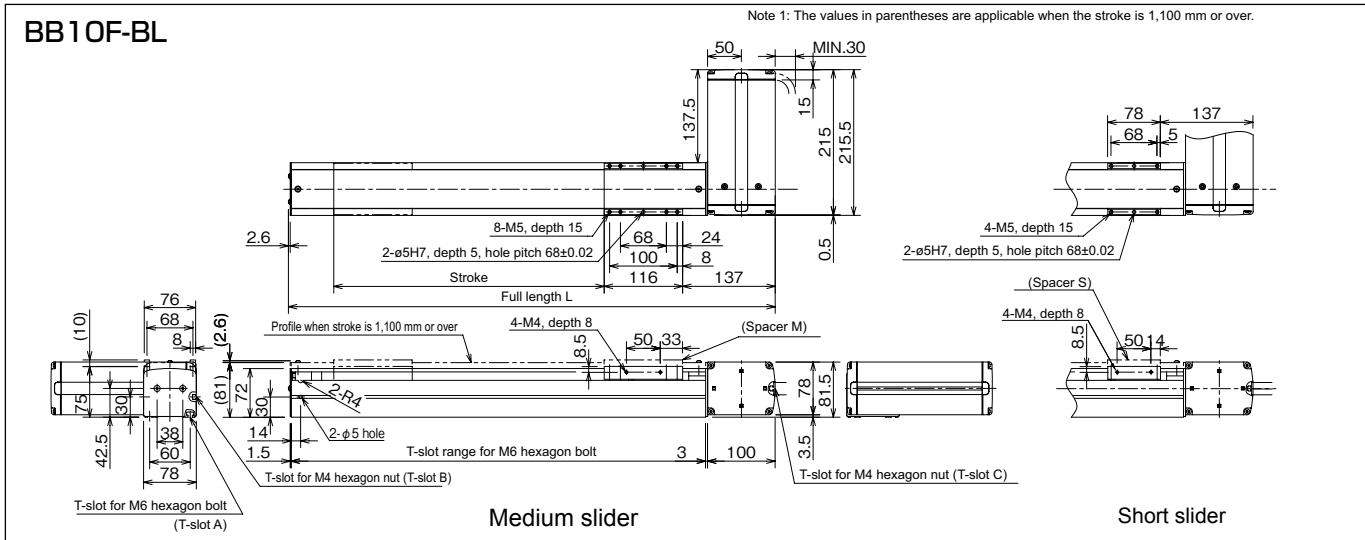
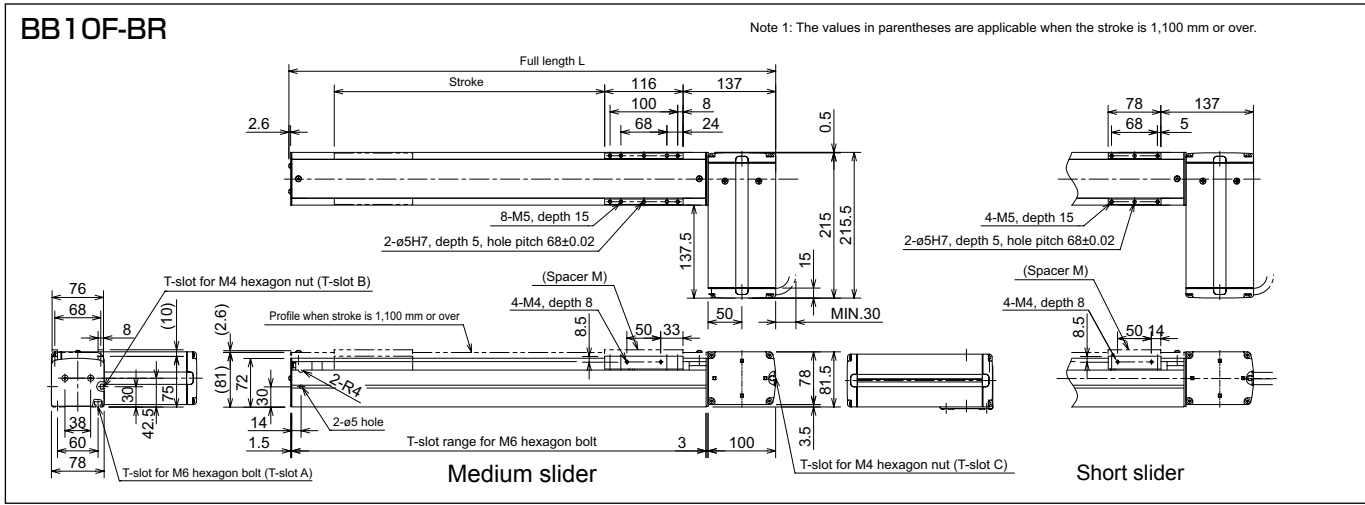

Common to BB10F-BT, BR, BL and BU.

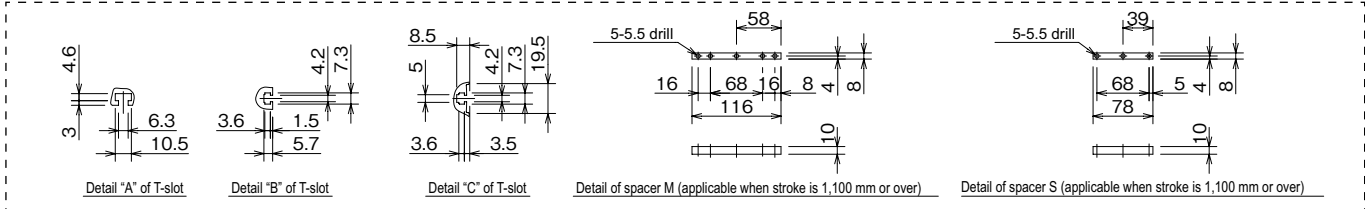

Medium slider Common to BB10F-BT, BR, BL and BU.

Stroke (mm)	100	200	300	400	500	600	700	800	900	1000	1100	1200	1300	1400	1500	1600	1700	1800
Full length L (mm)	420.1	520.1	620.1	720.1	820.1	920.1	1020.1	1120.1	1220.1	1320.1	1420.1	1520.1	1620.1	1720.1	1820.1	1920.1	2020.1	2120.1
Weight (kg)	5.8	6.4	7.0	7.6	8.2	8.8	9.4	10.0	10.6	11.2	11.8	12.4	13.0	13.6	14.2	14.8	15.4	16.0

Short slider Common to BB10F-BT, BR, BL and BU.

Stroke (mm)	150	250	350	450	550	650	750	850	950	1050	1150	1250	1350	1450	1550	1650	1750	1850
Full length L (mm)	420.1	520.1	620.1	720.1	820.1	920.1	1020.1	1120.1	1220.1	1320.1	1420.1	1520.1	1620.1	1720.1	1820.1	1920.1	2020.1	2120.1
Weight (kg)	5.5	6.1	6.7	7.3	7.9	8.5	9.1	9.7	10.3	10.9	11.5	12.1	12.7	13.3	13.9	14.5	15.1	15.7

[Set designation]

**BA2 – 30E – BT – M 21 N – 40 – 1 3**

Motor set direction BT: Facing up BR: Facing right BL: Facing left BU: Facing down	Type of slider M: Medium slider L: Long slider	Lead 21 : 21mm	Brake N : Without brake	Stroke See "Type designation" under "Stroke" of the specifications.	Controller 0 : None 1 : CA20 - M10 2 : CA10 - M00B 3 : CA10 - M01B	Cable length 3 : 3m 9 : 9m 5 : 5m B : 11m 7 : 7m D : 13m
--	--	-------------------	----------------------------	--	--	---

[Specifications]

Motor	100 W AC servo motor (absolute)																	
Drive system	Timing belt																	
Lead, converted into ball screw (mm)	21																	
Stroke (mm) (in increments of 100 mm)	Medium slider	100 ~ 900	1000	1100	1200	1300	1400	1500	1600	1700	1800	1900	2000	2100	2200	2300	2400	2500
	Type designation	10 ~ 90	A 0	B 0	C 0	D 0	E 0	F 0	G 0	H 0	J 0	K 0	L 0	M 0	N 0	P 0	Q 0	R 0
	Long slider	150 ~ 950	1050	1150	1250	1350	1450	1550	1650	1750	1850	1950	2050	2150	2250	2350	2450	
	Type designation	15 ~ 95	A 5	B 5	C 5	D 5	E 5	F 5	G 5	H 5	J 5	K 5	L 5	M 5	N 5	P 5	Q 5	
Maximum speed (mm/s)	1000																	
Maximum Payload (kg) <small>Acceleration/deceleration time: 0.3 sec. or over</small>	Horizontal transfer: 15																	
Positioning repeatability (mm)	±0.05																	
Resolution (mm)	0.01																	
Allowable static load moment (N·m)	Medium slider MR: 510, MP: 430, MY: 370 Long slider MR: 510, MP: 750, MY: 650																	
Master controller	Select from CA20-M10, CA10-M00B and CA10-M01B.																	

Notes: \* The maximum Payload signifies a load exerted on top of the slider. Also refer to the dynamic load moment given in pages 220 to 227.  
\* The acceleration/deceleration time represents the time until the axis reaches a programmed speed.

Timing Belt Driven

[Axis designation]

**BB30E – BT – M 21 N – 40**

Motor set direction BT: Facing up BR: Facing right BL: Facing left BU: Facing down	Type of slider M: Medium slider L: Long slider	Lead 21 : 21mm	Brake N : Without brake	Stroke See "Type designation" under "Stroke" of the specifications.
--	--	-------------------	----------------------------	--

[Dimensions]

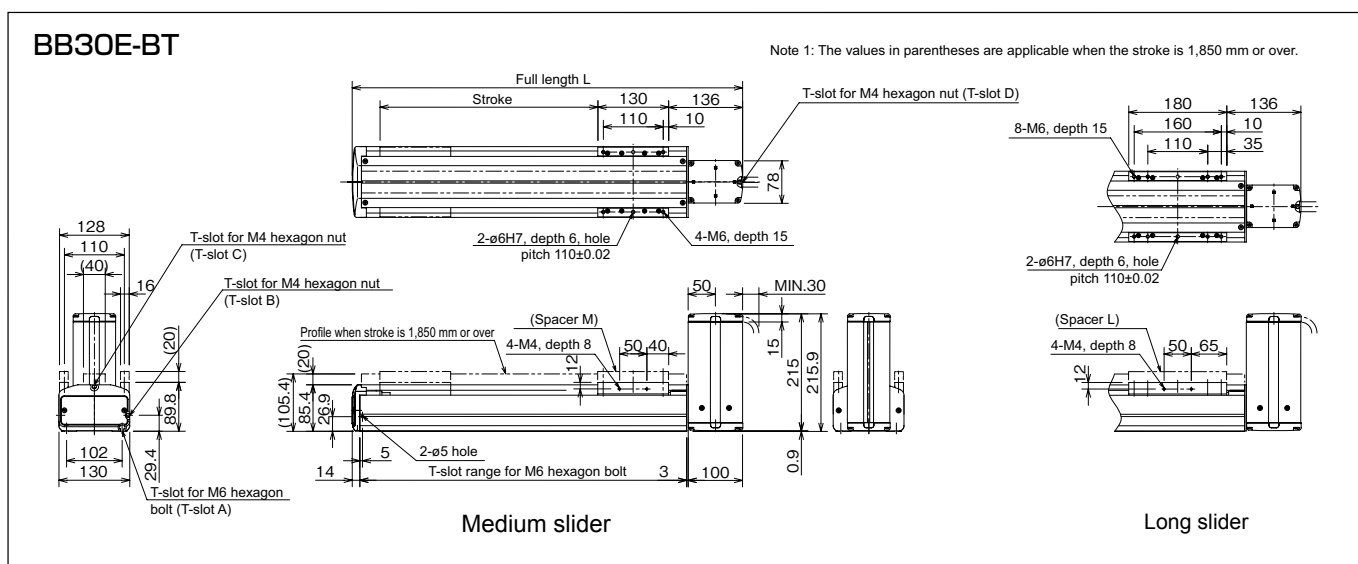



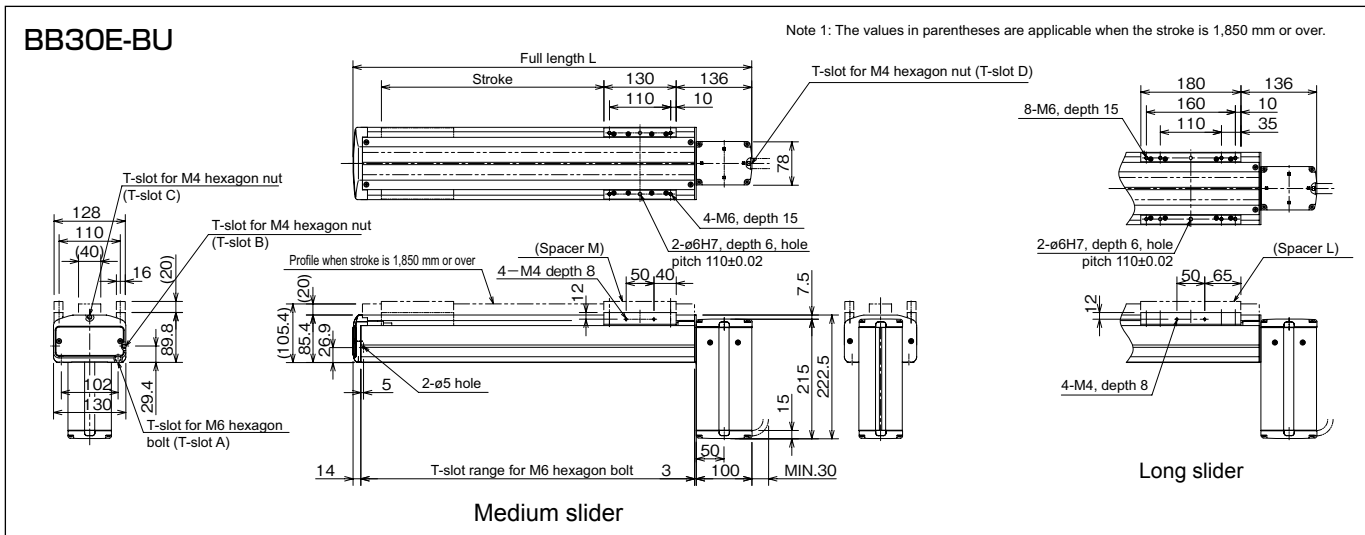
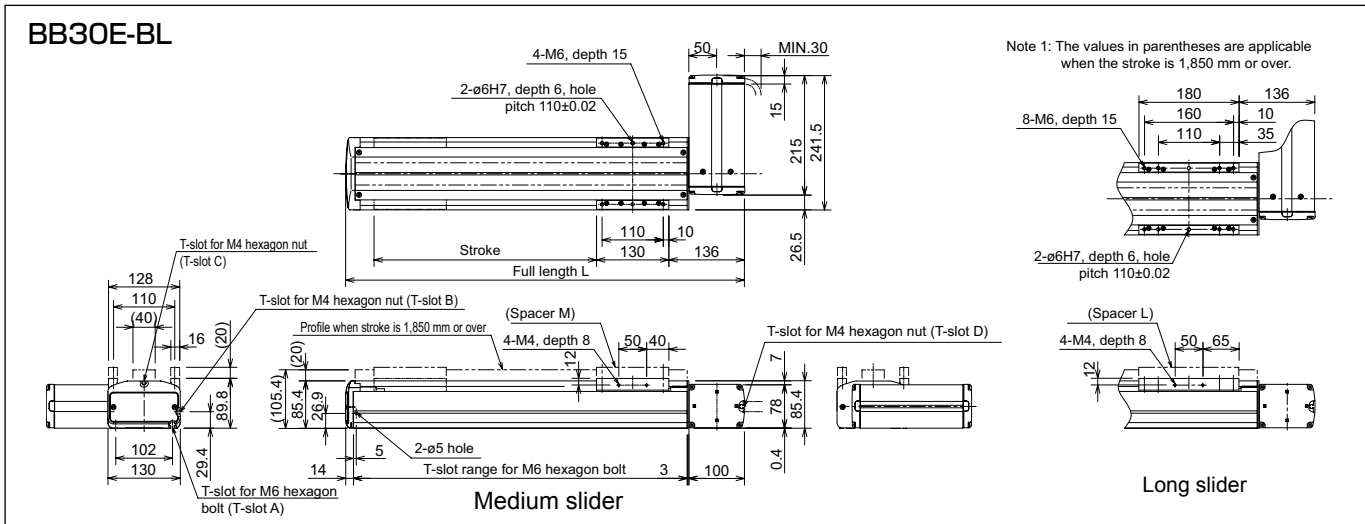
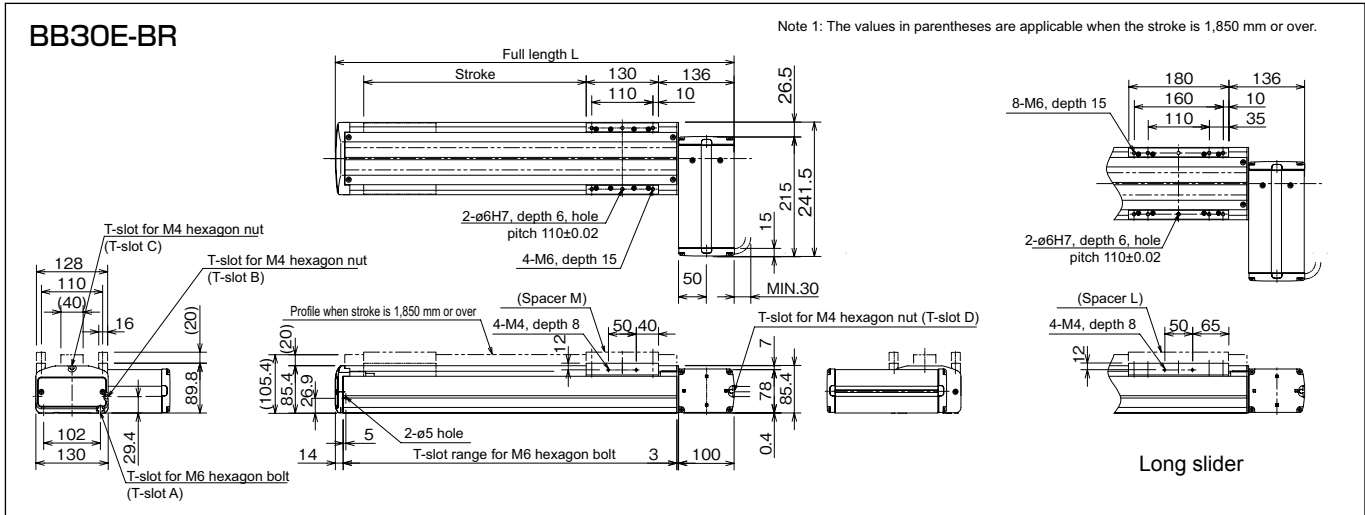

Common to BB30E-BT, BR, BL and BU.

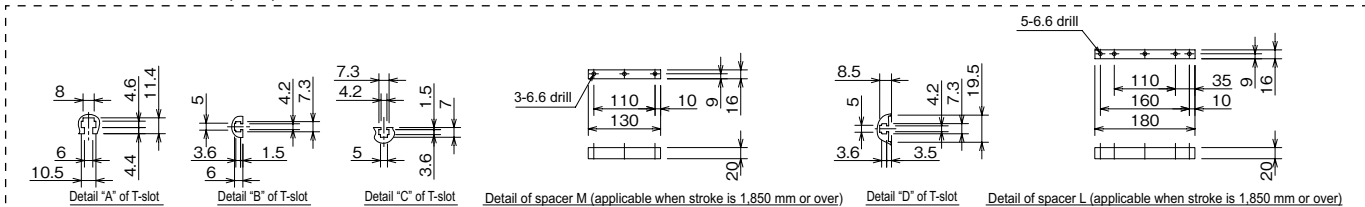

Medium slider Common to BB30E-BT, BR, BL and BU.

Stroke (mm)	100	200	300	400	500	600	700	800	900	1000	1100	1200	1300	1400	1500	1600	1700	1800	1900	2000	2100	2200	2300	2400	2500
Full length L (mm)	417	517	617	717	817	917	1017	1117	1217	1317	1417	1517	1617	1717	1817	1917	2017	2117	2217	2317	2417	2517	2617	2717	2817
Weight (kg)	7.9	9.0	10.1	11.2	12.3	13.4	14.5	15.6	16.7	17.8	18.9	20.0	21.1	22.2	23.3	24.4	25.5	26.6	27.7	28.8	29.9	31.0	32.1	33.2	34.3

Short slider Common to BB30E-BT, BR, BL and BU.

Stroke (mm)	150	250	350	450	550	650	750	850	950	1050	1150	1250	1350	1450	1550	1650	1750	1850	1950	2050	2150	2250	2350	2450
Full length L (mm)	517	617	717	817	917	1017	1117	1217	1317	1417	1517	1617	1717	1817	1917	2017	2117	2217	2317	2417	2517	2617	2717	2817
Weight (kg)	9.3	10.4	11.5	12.6	13.7	14.8	15.9	17.0	18.1	19.2	20.3	21.4	22.5	23.6	24.7	25.8	26.9	28.0	29.1	30.2	31.3	32.4	33.5	34.6

[Set designation]

**BA2 - 30F - BT - M 21 N - 40 - 1 3**

<b>Motor set direction</b> BT: Facing up BR: Facing right BL: Facing left BU: Facing down	<b>Type of slider</b> M: Medium slider L: Long slider	<b>Lead</b> 21 : 21mm 42 : 42mm	<b>Brake</b> N : Without brake	<b>Stroke</b> See "Type designation" under "Stroke" of the specifications.	<b>Controller</b> 0 : None 1 : CA20 - M10 2 : CA10 - M00B 3 : CA10 - M01B	<b>Cable length</b> 3 : 3m 9 : 9m 5 : 5m B : 11m 7 : 7m D : 13m
---	---	---------------------------------------	-----------------------------------	---	---	--

[Specifications]

Motor	200 W AC servo motor (absolute)																	
Drive system	Timing belt																	
Lead, converted into ball screw (mm)	21、42																	
Stroke (mm) (in increments of 100 mm)	Medium slider	100 ~ 900	1000	1100	1200	1300	1400	1500	1600	1700	1800	1900	2000	2100	2200	2300	2400	2500
	Type designation	10 ~ 90	A 0	B 0	C 0	D 0	E 0	F 0	G 0	H 0	J 0	K 0	L 0	M 0	N 0	P 0	Q 0	R 0
	Long slider	150 ~ 950	1050	1150	1250	1350	1450	1550	1650	1750	1850	1950	2050	2150	2250	2350	2450	
	Type designation	15 ~ 95	A 5	B 5	C 5	D 5	E 5	F 5	G 5	H 5	J 5	K 5	L 5	M 5	N 5	P 5	Q 5	
Maximum speed (mm/s)	Lead 21	1000																
	Lead 42	2000																
Maximum Payload (kg)	Lead 21	Horizontal transfer: 40, acceleration/deceleration time: 0.3 sec. or over																
	Lead 42	Horizontal transfer: 20, acceleration/deceleration time: 0.5 sec. or over																
Positioning repeatability (mm)	±0.05																	
Resolution (mm)	0.01																	
Allowable static load moment (N·m)	Medium slider MR: 510, MP: 430, MY: 370 Long slider MR: 510, MP: 750, MY: 650																	
Master controller	Select from CA20-M10, CA10-M00B and CA10-M01.																	

Notes: \* The maximum Payload signifies a load exerted on top of the slider. Also refer to the dynamic load moment given in pages 220 to 227.  
\* The acceleration/deceleration time represents the time until the axis reaches a programmed speed.

Timing Belt Driven

[Axis designation]

**BB30F - BT - M 21 N - 40**

<b>Motor set direction</b> BT: Facing up BR: Facing right BL: Facing left BU: Facing down	<b>Type of slider</b> M: Medium slider L: Long slider	<b>Lead</b> 21 : 21mm 42 : 42mm	<b>Brake</b> N : Without brake	<b>Stroke</b> See "Type designation" under "Stroke" of the specifications.
---	---	---------------------------------------	-----------------------------------	---

[Dimensions]

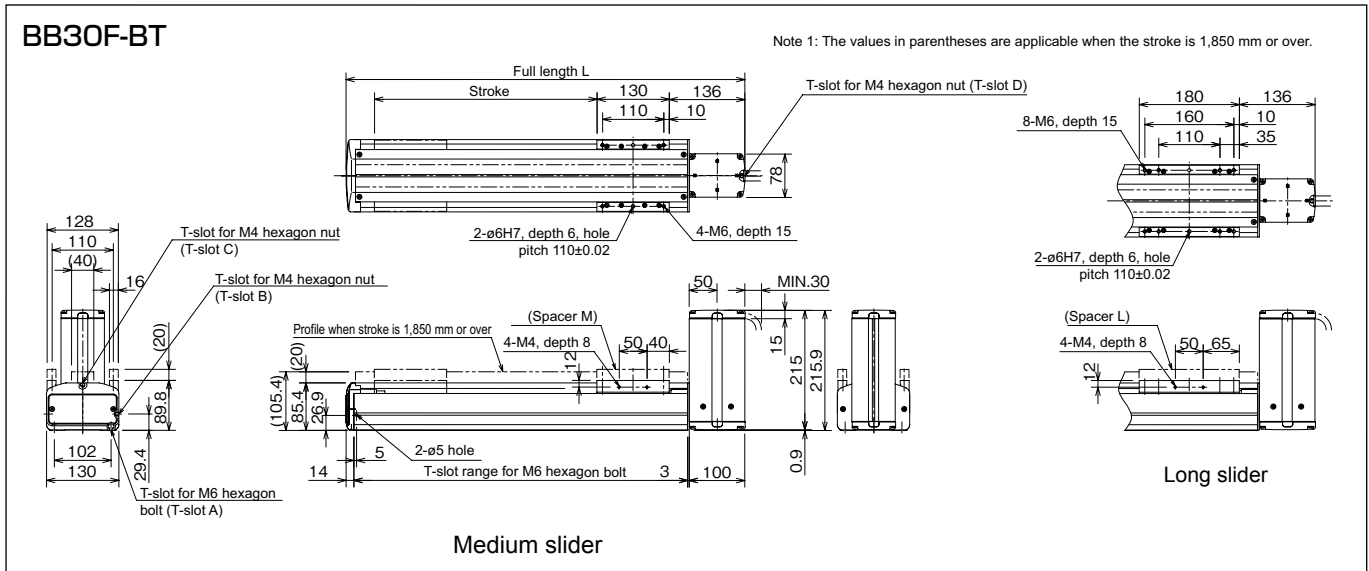

BB30F-BR

Note 1: The values in parentheses are applicable when the stroke is 1,850 mm or over.

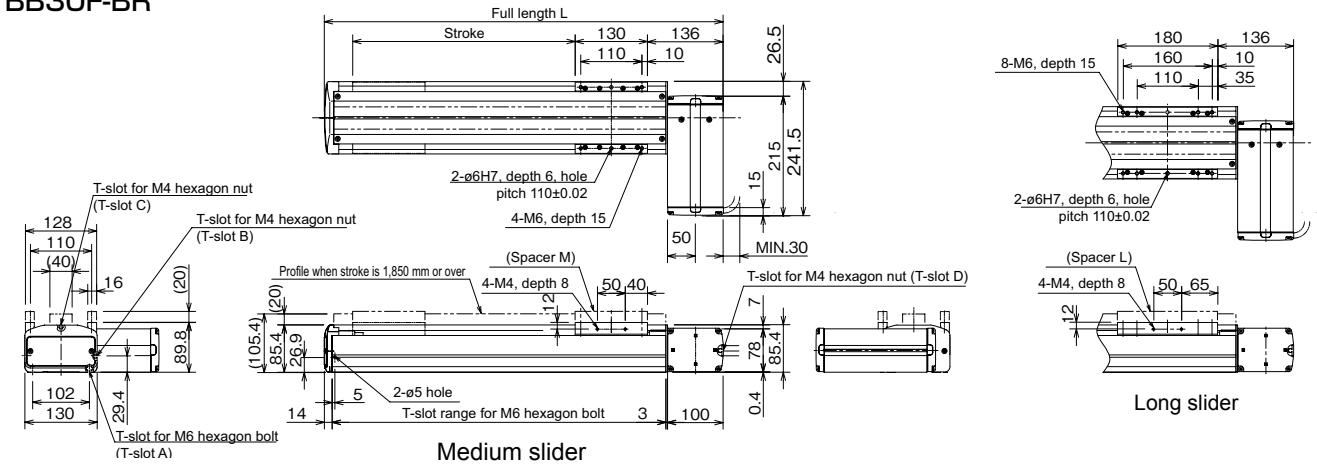

BB30F-BL

Note 1: The values in parentheses are applicable when the stroke is 1,850 mm or over.

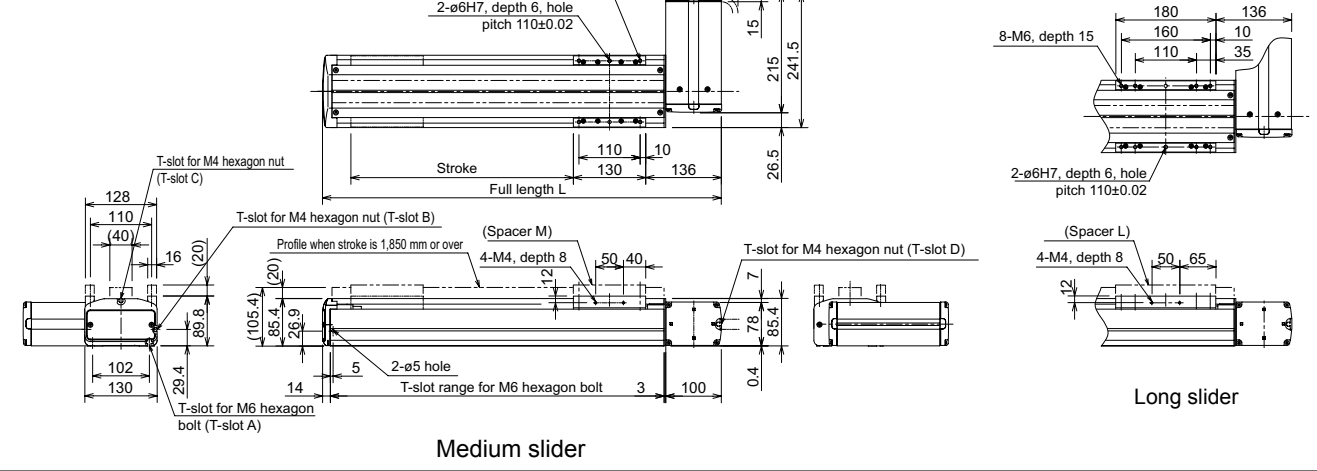

BB30F-BU

Note 1: The values in parentheses are applicable when the stroke is 1,850 mm or over.

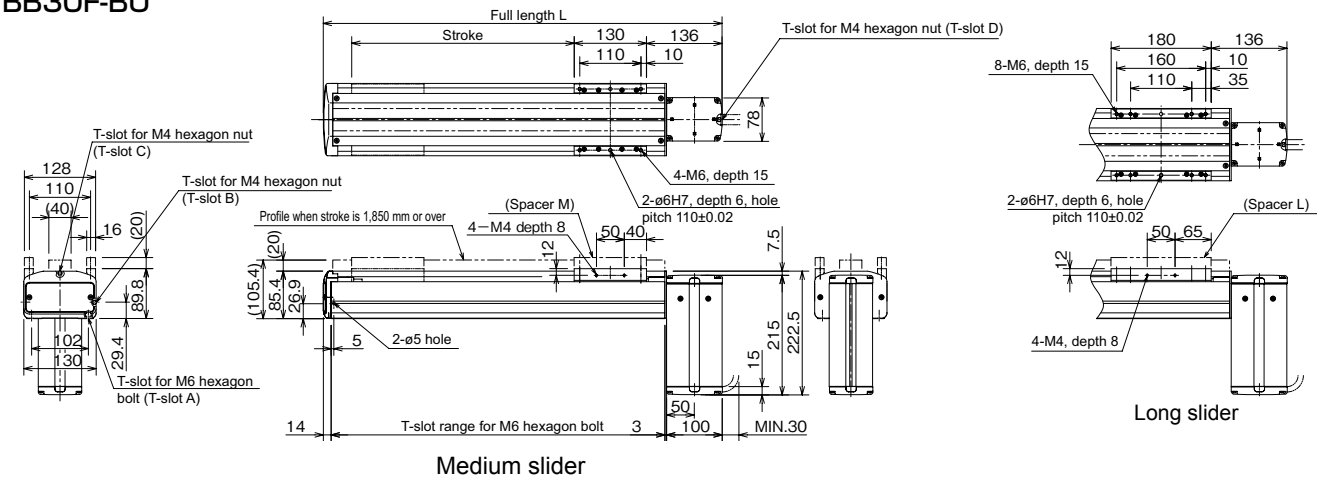

Common to BB30F-BT, BR, BL and BU.

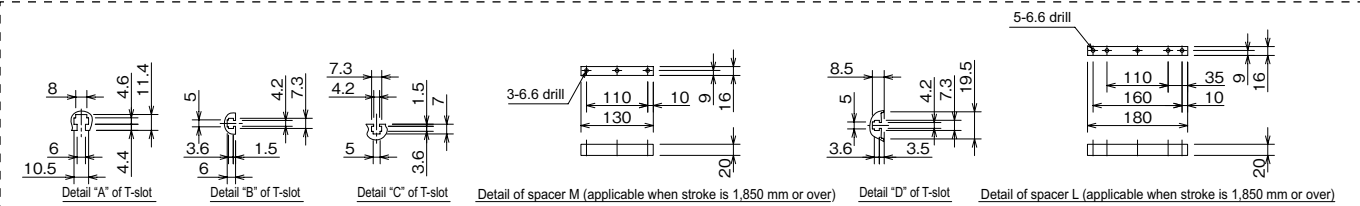

Medium slider Common to BB30F-BT, BR, BL and BU.

Stroke (mm)	100	200	300	400	500	600	700	800	900	1000	1100	1200	1300	1400	1500	1600	1700	1800	1900	2000	2100	2200	2300	2400	2500
Full length L (mm)	417	517	617	717	817	917	1017	1117	1217	1317	1417	1517	1617	1717	1817	1917	2017	2117	2217	2317	2417	2517	2617	2717	2817
Weight (kg)	8.7	9.8	10.9	12.0	13.1	14.2	15.3	16.4	17.5	18.6	19.7	20.8	21.9	23.0	24.1	25.2	26.3	27.4	28.5	29.6	30.7	31.8	32.9	34.0	35.1

Long slider Common to BB30F-BT, BR, BL and BU.

Stroke (mm)	150	250	350	450	550	650	750	850	950	1050	1150	1250	1350	1450	1550	1650	1750	1850	1950	2050	2150	2250	2350	2450
Full length L (mm)	517	617	717	817	917	1017	1117	1217	1317	1417	1517	1617	1717	1817	1917	2017	2117	2217	2317	2417	2517	2617	2717	2817
Weight (kg)	10.1	11.2	12.3	13.4	14.5	15.6	16.7	17.8	18.9	20.0	21.1	22.2	23.3	24.4	25.5	26.6	27.7	28.8	29.9	31.0	32.1	33.2	34.3	35.4

[Set designation]

**BA2 – 50F – BT – M 21 N – 40 – 1 3**

<b>Motor set direction</b> BT: Facing up BR: Facing right BL: Facing left BU: Facing down	<b>Type of slider</b> M: Medium slider L: Long slider	<b>Lead</b> 21 : 21mm	<b>Brake</b> N : Without brake	<b>Stroke</b> See "Type designation" under "Stroke" of the specifications.	<b>Controller</b> 0 : None 1 : CA20 - M10 2 : CA10 - M00B 3 : CA10 - M01B	<b>Cable length</b> 3 : 3m 9 : 9m 5 : 5m B : 11m 7 : 7m D : 13m
---	---	--------------------------	-----------------------------------	---	---	--

[Specifications]

Motor	200 W AC servo motor (absolute)																	
Drive system	Timing belt																	
Lead, converted into ball screw (mm)	21																	
Stroke (mm) (in increments of 100 mm)	Medium slider	200 ~ 900	1000	1100	1200	1300	1400	1500	1600	1700	1800	1900	2000	2100	2200	2300	2400	2500
	Type designation	20 ~ 90	A 0	B 0	C 0	D 0	E 0	F 0	G 0	H 0	J 0	K 0	L 0	M 0	N 0	P 0	Q 0	R 0
	Long slider	250 ~ 950	1050	1150	1250	1350	1450	1550	1650	1750	1850	1950	2050	2150	2250	2350	2450	
	Type designation	25 ~ 95	A 5	B 5	C 5	D 5	E 5	F 5	G 5	H 5	J 5	K 5	L 5	M 5	N 5	P 5	Q 5	
Maximum speed (mm/s)	1000																	
Maximum Payload (kg) <small>Acceleration/deceleration time: 0.3 sec. or over</small>	Horizontal transfer: 40																	
Positioning repeatability (mm)	±0.05																	
Resolution (mm)	0.01																	
Allowable static load moment (N·m)	Medium slider MR: 2080, MP: 2160, MY: 1820 Long slider MR: 2080, MP: 3150, MY: 2640																	
Master controller	Select from CA20-M10, CA10-M00B and CA10-M01B.																	

Notes: \* The maximum Payload signifies a load exerted on top of the slider. Also refer to the dynamic load moment given in pages 220 to 227.  
\* The acceleration/deceleration time represents the time until the axis reaches a programmed speed.

Timing Belt Driven

[Axis designation]

**BB50F – BT – M 21 N – 40**

<b>Motor set direction</b> BT: Facing up BR: Facing right BL: Facing left BU: Facing down	<b>Type of slider</b> M: Medium slider L: Long slider	<b>Lead</b> 21 : 21mm	<b>Brake</b> N : Without brake	<b>Stroke</b> See "Type designation" under "Stroke" of the specifications.
---	---	--------------------------	-----------------------------------	---

[Dimensions]

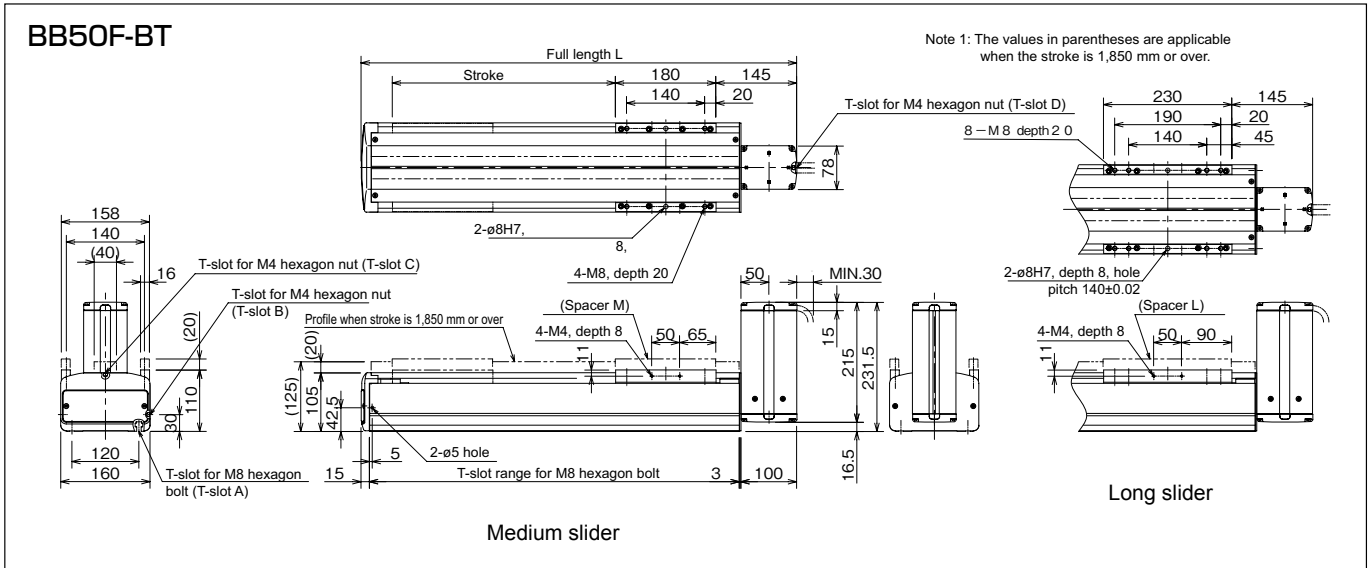

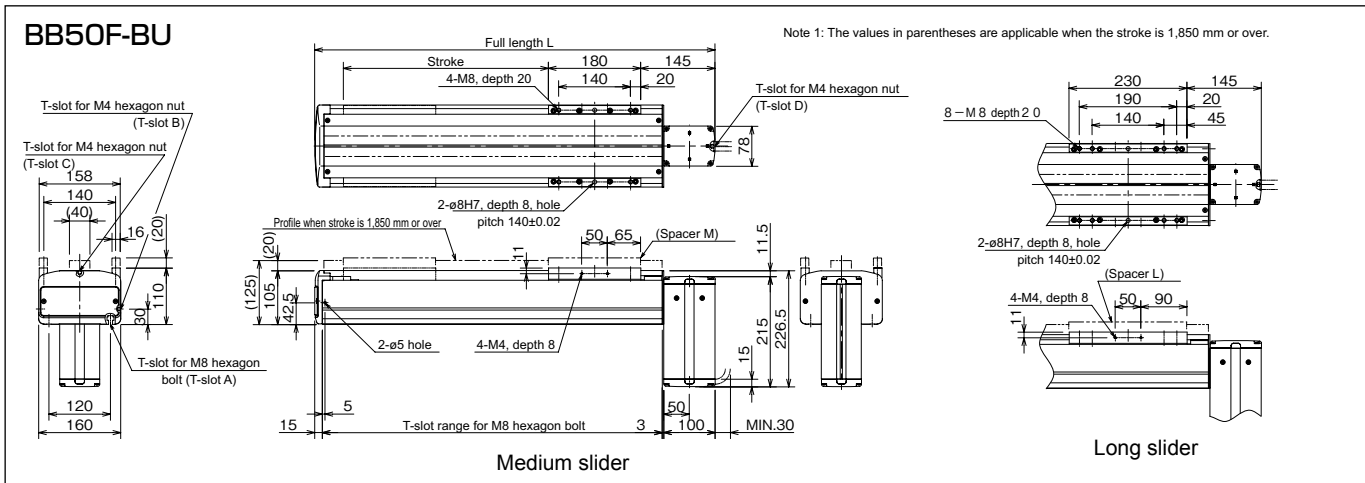
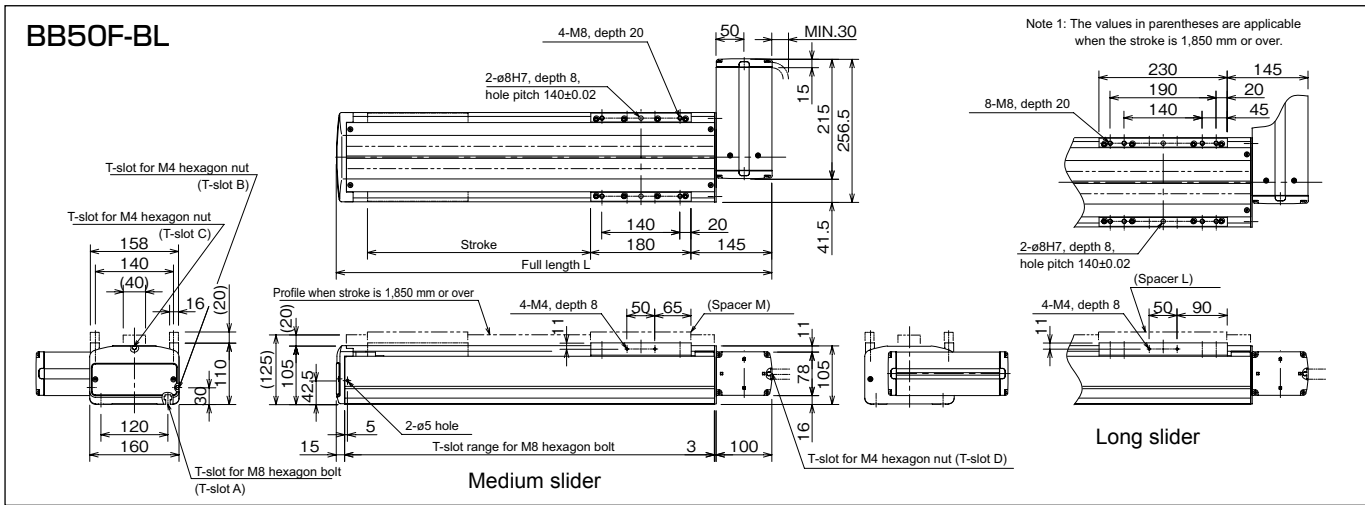
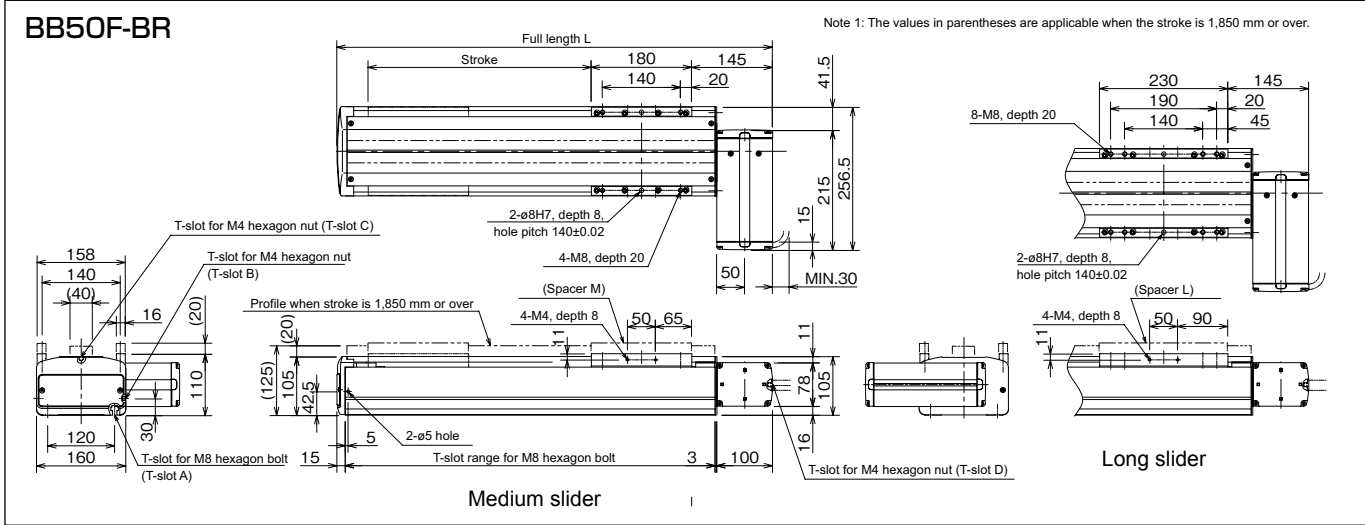

Common to BB50F-BT, BR, BL and BU.

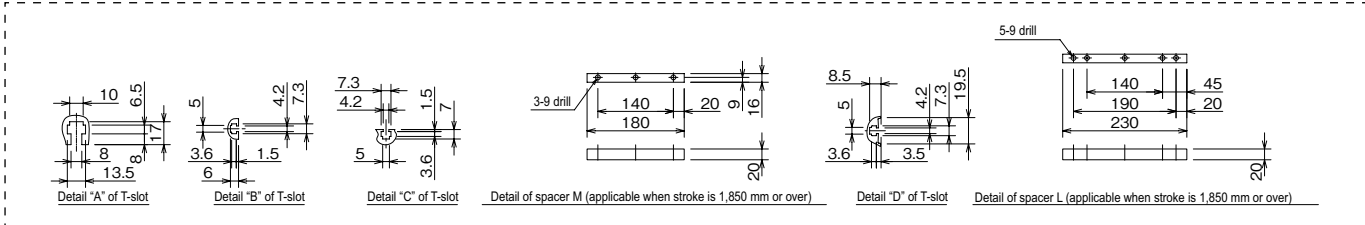

Medium slider Common to BB50F-BT, BR, BL and BU.

Stroke (mm)	200	300	400	500	600	700	800	900	1000	1100	1200	1300	1400	1500	1600	1700	1800	1900	2000	2100	2200	2300	2400	2500
Full length L (mm)	581	681	781	881	981	1081	1181	1281	1381	1481	1581	1681	1781	1881	1981	2081	2181	2281	2381	2481	2581	2681	2781	2881
Weight (kg)	12.9	14.6	16.3	18.0	19.7	21.4	23.1	24.8	26.5	28.2	29.9	31.6	33.3	35.0	36.7	38.4	40.1	41.8	43.5	45.2	46.9	48.6	50.3	52.0

Long slider Common to BB50F-BT, BR, BL and BU.

Stroke (mm)	250	350	450	550	650	750	850	950	1050	1150	1250	1350	1450	1550	1650	1750	1850	1950	2050	2150	2250	2350	2450
Full length L (mm)	681	781	881	981	1081	1181	1281	1381	1481	1581	1681	1781	1881	1981	2081	2181	2281	2381	2481	2581	2681	2781	2881
Weight (kg)	15.2	16.9	18.6	20.3	22.0	23.7	25.4	27.1	28.8	30.5	32.2	33.9	35.6	37.3	39.0	40.7	42.4	44.1	45.8	47.5	49.2	50.9	52.6

[Set designation]

**BA2 – 50G – BT – M 42 N – 40 – 1 3**

<b>Motor set direction</b> BT: Facing up BR: Facing right BL: Facing left BU: Facing down	<b>Type of slider</b> M: Medium slider L: Long slider	<b>Lead</b> 42 : 42mm	<b>Brake</b> N : Without brake	<b>Stroke</b> See "Type designation" under "Stroke" of the specifications.	<b>Controller</b> 0 : None 1 : CA20 - M40 2 : CA10 - M00B 3 : CA10 - M01B	<b>Cable length</b> 3 : 3m 9 : 9m 5 : 5m B : 11m 7 : 7m D : 13m
---	---	--------------------------	-----------------------------------	---	---	--

[Specifications]

Motor	400 W AC servo motor (absolute)																	
Drive system	Timing belt																	
Lead, converted into ball screw (mm)	42																	
Stroke (mm) (in increments of 100 mm)	Medium slider	200 ~ 900	1000	1100	1200	1300	1400	1500	1600	1700	1800	1900	2000	2100	2200	2300	2400	2500
	Type designation	20 ~ 90	A 0	B 0	C 0	D 0	E 0	F 0	G 0	H 0	J 0	K 0	L 0	M 0	N 0	P 0	Q 0	R 0
	Long slider	250 ~ 950	1050	1150	1250	1350	1450	1550	1650	1750	1850	1950	2050	2150	2250	2350	2450	
	Type designation	25 ~ 95	A 5	B 5	C 5	D 5	E 5	F 5	G 5	H 5	J 5	K 5	L 5	M 5	N 5	P 5	Q 5	
Maximum speed (mm/s)	2000																	
Maximum Payload (kg) <small>Acceleration/deceleration time: 0.5 sec. or over</small>	Horizontal transfer: 20																	
Positioning repeatability (mm)	±0.05																	
Resolution (mm)	0.01																	
Allowable static load moment (N·m)	Medium slider MR: 2080, MP: 2160, MY: 1820 Long slider MR: 2080, MP: 3150, MY: 2640																	
Master controller	Select from CA20-M40, CA10-M00B and CA10-M01B.																	

Notes: \* The maximum Payload signifies a load exerted on top of the slider. Also refer to the dynamic load moment given in pages 220 to 227.

\* The acceleration/deceleration time represents the time until the axis reaches a programmed speed.

Timing Belt Driven

[Axis designation]

**BB50G – BT – M 42 N – 40**

<b>Motor set direction</b> BT: Facing up BR: Facing right BL: Facing left BU: Facing down	<b>Type of slider</b> M: Medium slider L: Long slider	<b>Lead</b> 42 : 42mm	<b>Brake</b> N : Without brake	<b>Stroke</b> See "Type designation" under "Stroke" of the specifications.
---	---	--------------------------	-----------------------------------	---

[Dimensions]

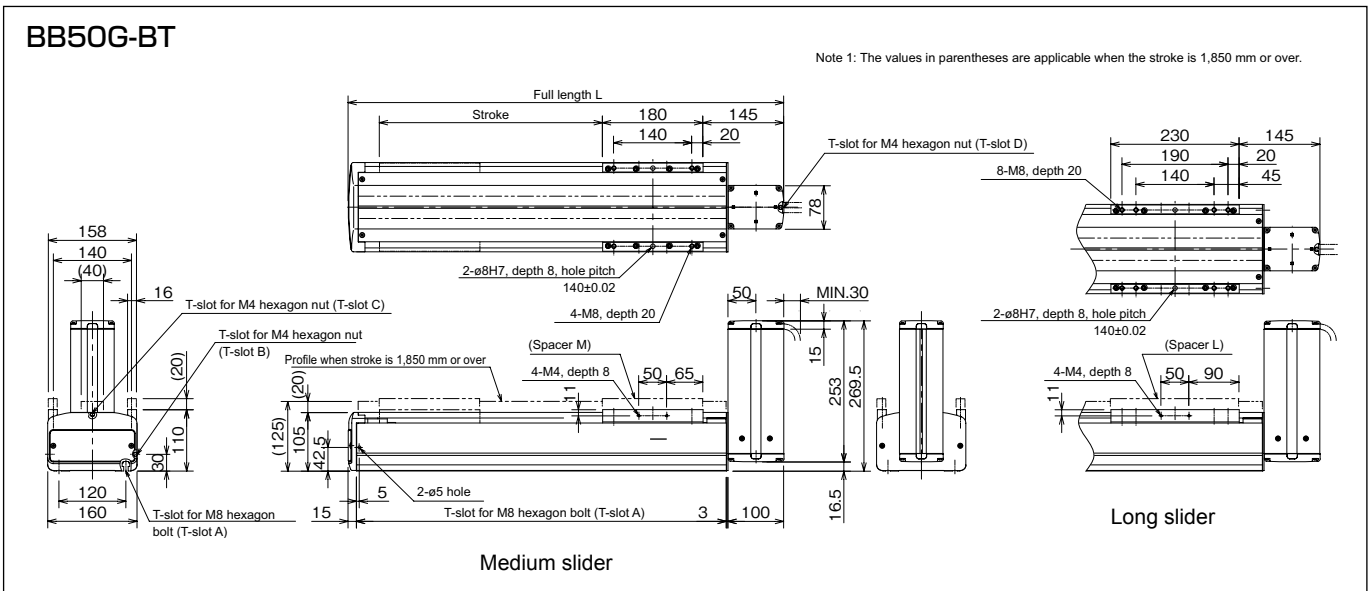

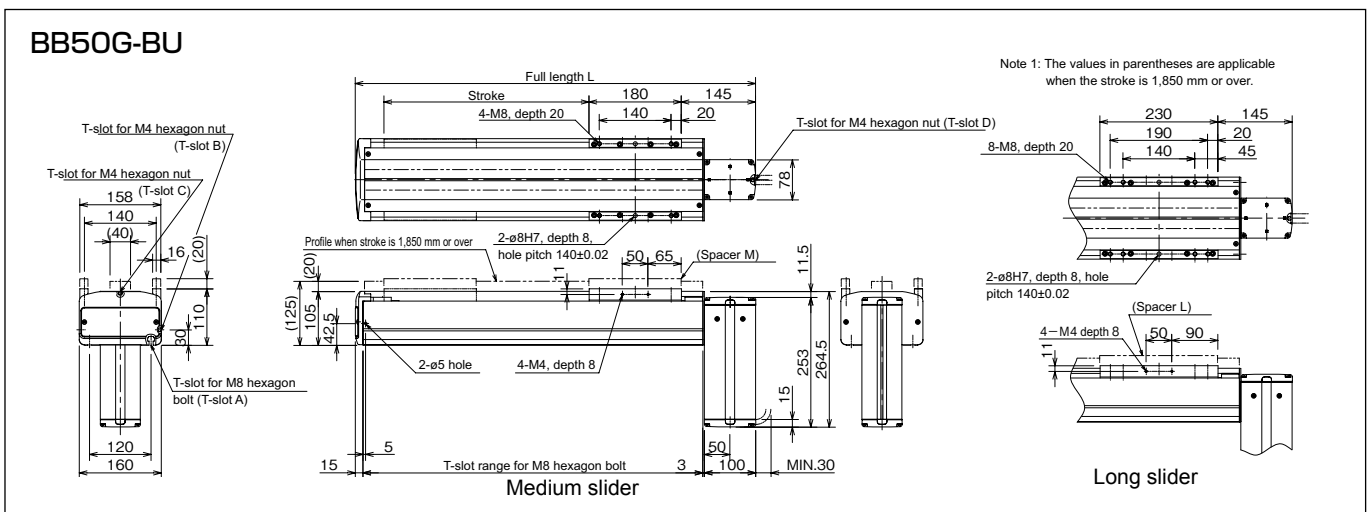
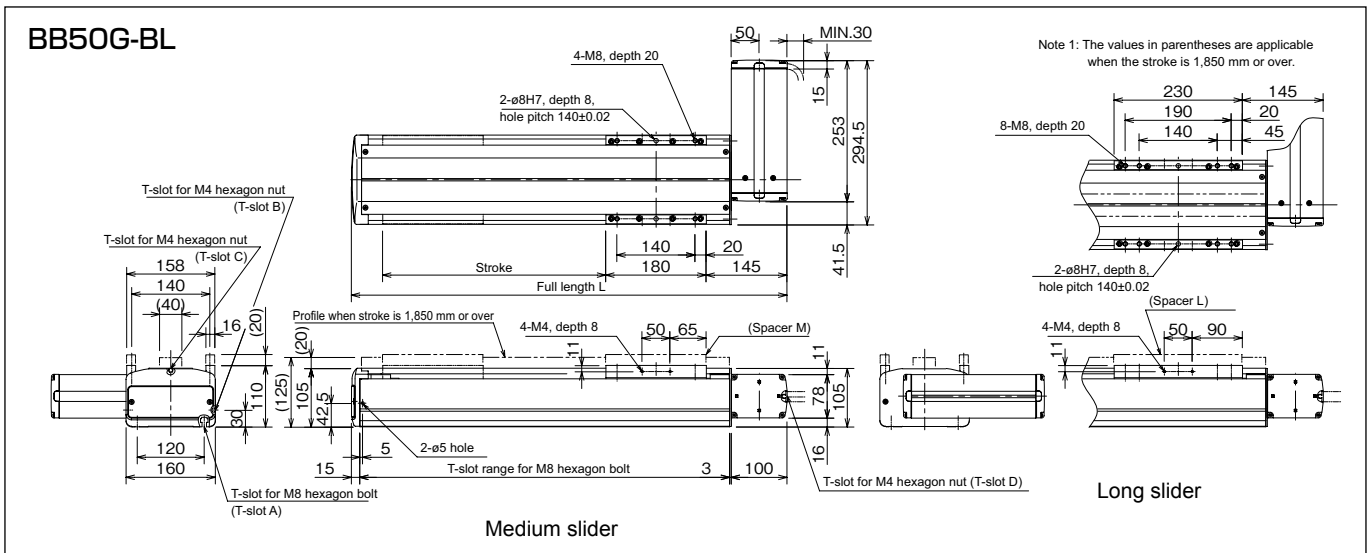
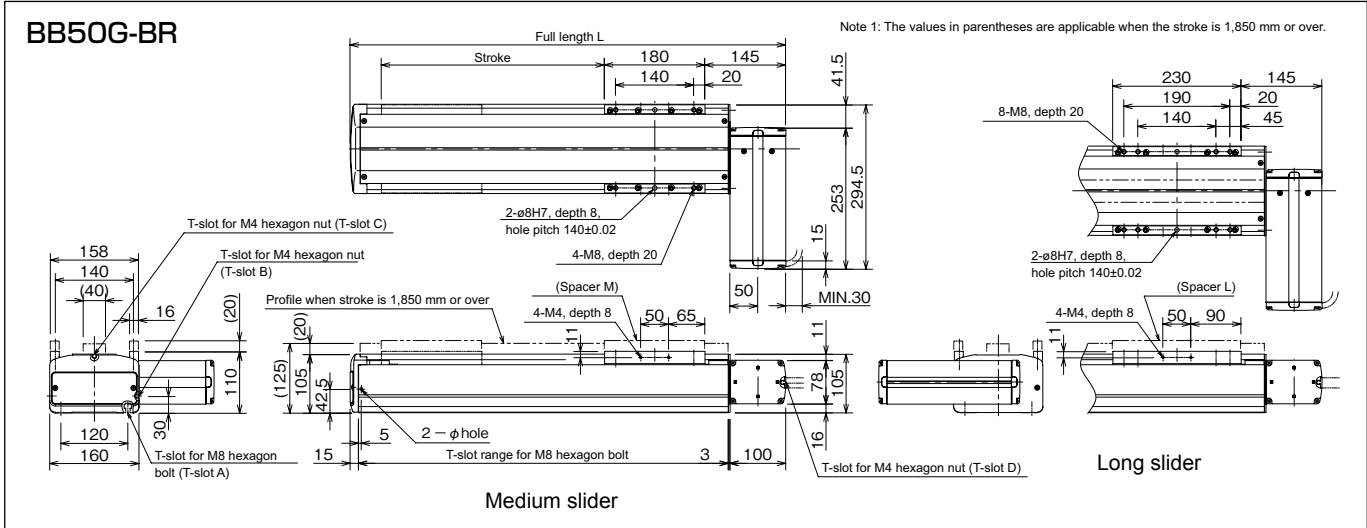

Common to BB50G-BT, BR, BL and BU.

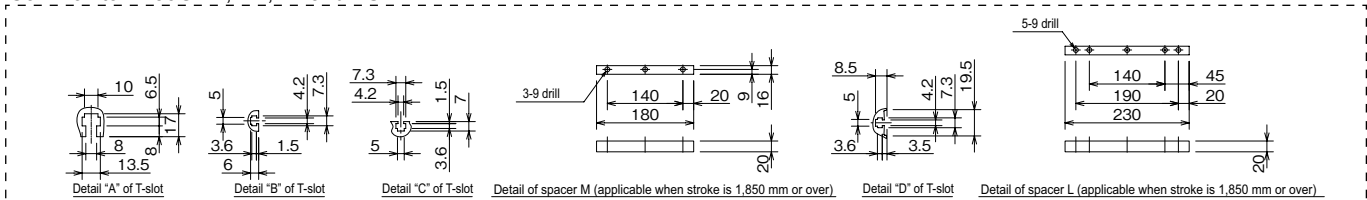

Medium slider

Common to BB50G-BT, BR, BL and BU.

Stroke (mm)	200	300	400	500	600	700	800	900	1000	1100	1200	1300	1400	1500	1600	1700	1800	1900	2000	2100	2200	2300	2400	2500
Full length L (mm)	581	681	781	881	981	1081	1181	1281	1381	1481	1581	1681	1781	1881	1981	2081	2181	2281	2381	2481	2581	2681	2781	2881
Weight (kg)	13.5	15.2	16.9	18.6	20.3	22.0	23.7	25.4	27.1	28.8	30.5	32.2	33.9	35.6	37.3	39.0	40.7	42.4	44.1	45.8	47.5	49.2	50.9	52.6

Long slider

Common to BB50G-BT, BR, BL and BU.

Stroke (mm)	250	350	450	550	650	750	850	950	1050	1150	1250	1350	1450	1550	1650	1750	1850	1950	2050	2150	2250	2350	2450
Full length L (mm)	681	781	881	981	1081	1181	1281	1381	1481	1581	1681	1781	1881	1981	2081	2181	2281	2381	2481	2581	2681	2781	2881
Weight (kg)	15.8	17.5	19.2	20.9	22.6	24.3	26.0	27.7	29.4	31.1	32.8	34.5	36.2	37.9	39.6	41.3	43.0	44.7	46.4	48.1	49.8	51.5	53.2

[Set designation]

**BA2 – 00D – RH – A 00N – 36 – 1 3**

<b>Drive system</b> RH: Harmonic	<b>Mounting</b> A: L-shaped bracket F: Flange type	<b>Range of rotation</b> 360°	<b>Controller</b> 0 : None 1 : CA20 - M10 2 : CA10 - M00B 3 : CA10 - M01B	<b>Cable length</b> 3 : 3m 9 : 9m 5 : 5m B : 11m 7 : 7m D : 13m
-------------------------------------	--	----------------------------------	---	--

[Specifications]

Motor	50 W AC servo motor (absolute)	
Drive system	Harmonic drive	
Reduction ratio (deg.)	1/50	
Range of rotation (deg.)	360	
Maximum speed (deg. /s)	360	
Maximum Payload (kg)	5	
Acceleration/deceleration time: 0.3 sec. or over		
Rated output torque (N·m)	2.5	
Allowable load inertia (kg·m <sup>2</sup> )	0.0485	
Allowable thrust load on axis (N)	49	
Allowable radial load on axis (N)	98	
Allowable load moment on axis (N·m)	0.65	
Positioning repeatability (deg.)	±0.025	
Resolution (deg.)	0.01	
Mass of axis (kg)	L-shaped bracket	2.0
	Flange type	1.8
Master controller	Select from CA20-M10, CA10-M00B and CA10-M01B.	

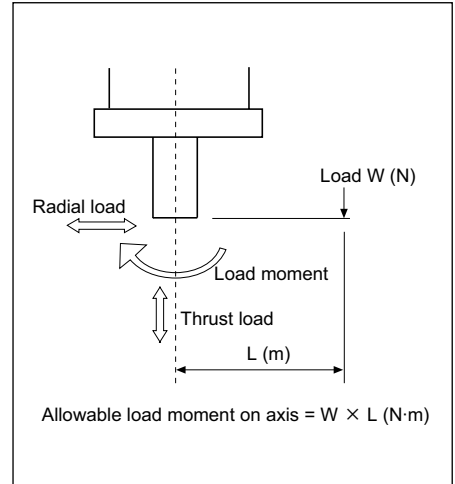

Notes: \* The maximum Payload signifies a load measured when only thrust load is exerted on the vertically installed axis.  
\* The acceleration/deceleration time represents the time until the axis reaches a programmed speed.

R-Axis

[Axis designation]

**BB00D – RH – A**

<b>Drive system</b> RH: Harmonic	<b>Mounting</b> A: L-shaped bracket F: Flange type
-------------------------------------	--

[Dimensions]

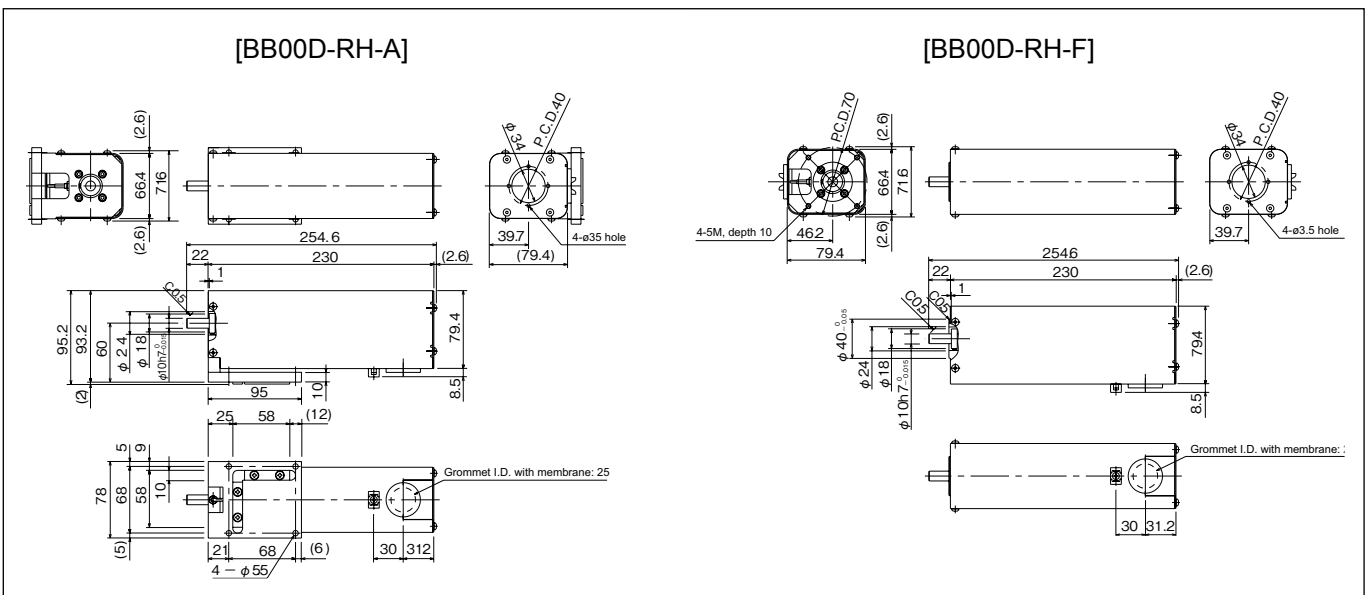



[Set designation]

**BA2 – OOD – RP – A OON – 36 – 1 3**

Drive system RP: Planet gear	Mounting A: L-shaped bracket F: Flange type	Range of rotation 360°	Controller 0 : None 1 : CA20 - M10 2 : CA10 - M00B 3 : CA10 - M01B	Cable length 3 : 3m 9 : 9m 5 : 5m B : 11m 7 : 7m D : 13m
---------------------------------	---	---------------------------	--	---

[Specifications]

Motor	50 W AC servo motor (absolute)	
Drive system	Planet gear	
Reduction ratio (deg.)	1/21	
Range of rotation (deg.)	360	
Maximum speed (deg. /s)	857	
Maximum Payload (kg)	10	
Acceleration/deceleration time: 0.3 sec. or over		
Rated output torque (N·m)	3.9	
Allowable load inertia (kg·m <sup>2</sup> )	0.0125	
Allowable thrust load on axis (N)	98	
Allowable radial load on axis (N)	196	
Allowable load moment on axis (N·m)	1.3	
Positioning repeatability (deg.)	±0.125	
Resolution (deg.)	0.01	
Mass of axis (kg)	L-shaped bracket	2.4
	Flange type	2.2
Master controller	Select from CA20-M10, CA10-M00B and CA10-M01B.	

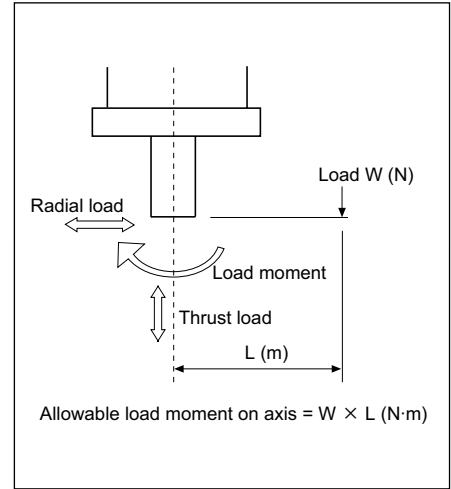

Notes: \* The maximum Payload signifies a load measured when only thrust load is exerted on the vertically installed axis.  
 \* The acceleration/deceleration time represents the time until the axis reaches a programmed speed.

R-Axis

[Axis designation]

**BBOOD – RP – A**

Drive system RP: Planet gear	Mounting A: L-shaped bracket F: Flange type
---------------------------------	---

[Dimensions]

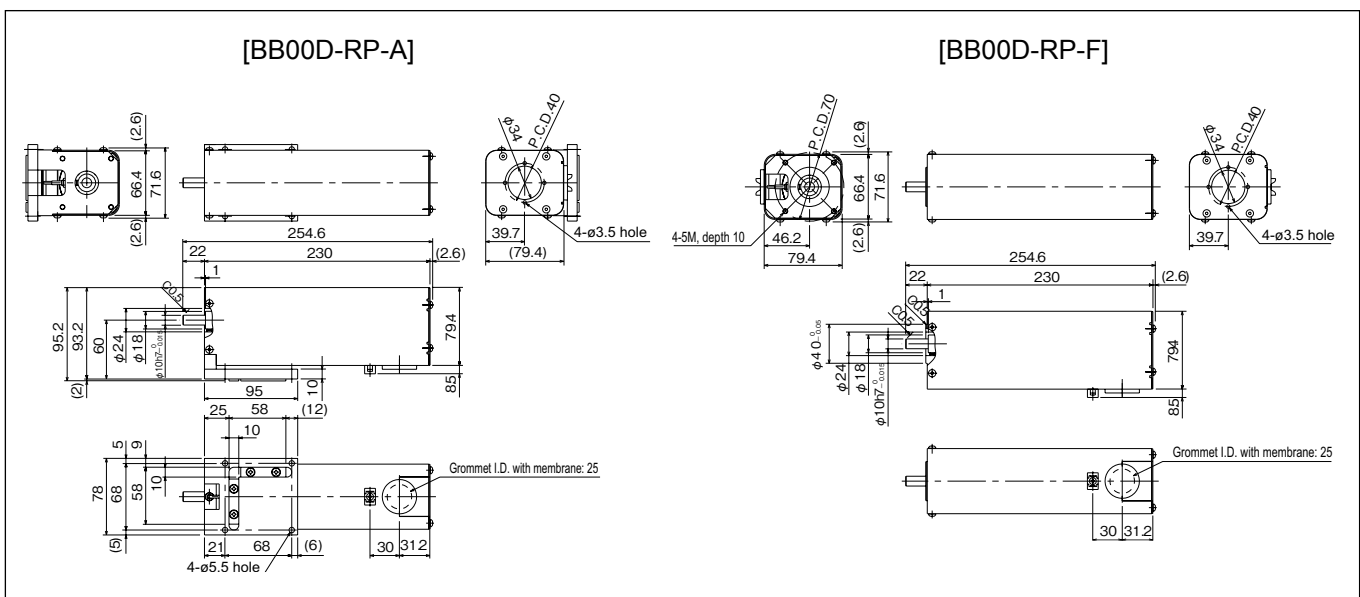



# Orthogonal Axes Specifications

## 2-Axis Specifications

### X-Y Combination

Ball screw type ..... 50

Timing belt type ..... 72

### X-Z Combination

Ball screw type ..... 79

Timing belt type ..... 91

### Y-Z Combination

Ball screw type ..... 97

Timing belt type ..... 109

### Z-Y Combination

Ball screw type ..... 115

Timing belt type ..... 125

## 3-Axis Specifications

### X-Y-Z Combination

Ball screw type ..... 131

Timing belt type ..... 155

## 4-Axis Specifications

### X-Y-Z-R Combination

Harmonic drive type ..... 163

Planet gear type ..... 167

[Set designation]

**BA2 – K7 – A2A R A – 40 40 00 – 00 1 3**

Combined operation	Axis 1 stroke	Axis 2 stroke	Controller	Cable length
R: Right-handed	05 : 50mm	05 : 50mm	0: None	3 : 3m 9 : 9m
L: Left-handed	60 : 600mm	40 : 400mm	1: CA20-M10	5 : 5m B : 11m
			2: CA10-M00B	7 : 7m D : 13m
			3: CA10-M01B	

**Ball screw type**

X-axis: Ball screw driven  
Motor straight

Y-axis: Ball screw driven  
Motor straight

[Specifications]

	X-axis	Y-axis
Type of axis	BB07D-ST-M12N- □□	BB05D-ST-M12N- □□
Stroke (in increments of 50 mm)	50 ~ 600mm	50 ~ 400mm
Maximum speed	800 mm/s (Note 1)	800mm/s
Positioning repeatability (mm)	±0.02mm	
Lead of ball screw	12mm	12mm
Motor output	50W	50W
Resolution	0.01mm	

Note 1: When the stroke is as given below, the maximum speed differs.

	Stroke (mm)	Maximum speed (mm/s)
X-axis	450 ~ 500	600
	550 ~ 600	400

Acceleration/deceleration time when the maximum speed is set: 0.3 sec. or over

Maximum Payload (kg)	Y-axis stroke							
	50mm	100mm	150mm	200mm	250mm	300mm	350mm	400mm
	5.0	5.0	4.0	4.0	2.0	2.0	1.0	1.0

**R: Right-handed**

Stroke X (BA07)	50	100	150	200	250	300	350	400	450	500	550	600
No. of holes B	4	4	6	6	8	8	10	10	12	12	14	14
Hole-to-hole pitch C	1	1	2	2	3	3	4	4	5	5	6	6

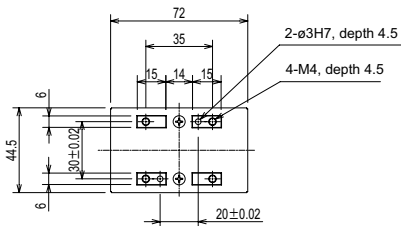

Y-axis slider unit

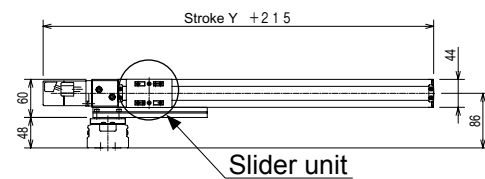

Slider unit

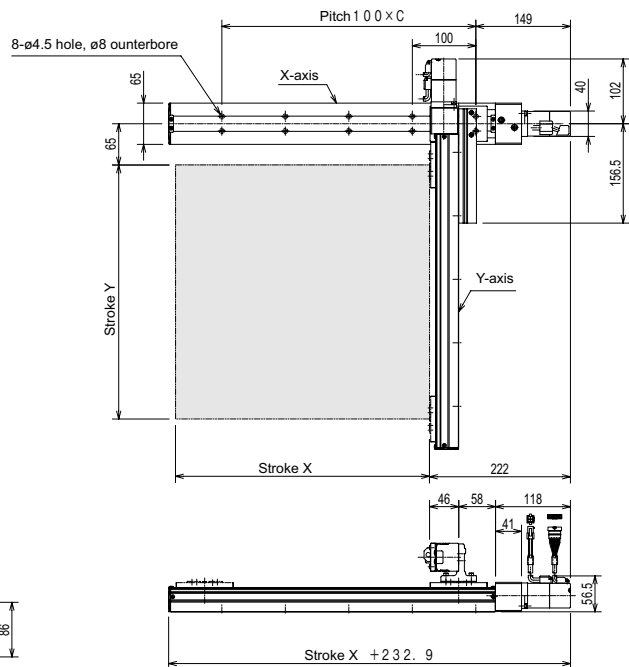

**L: Left-handed**

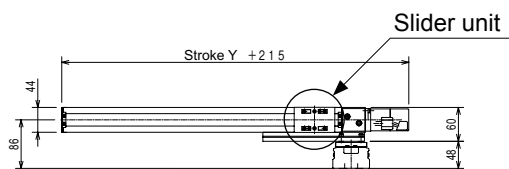
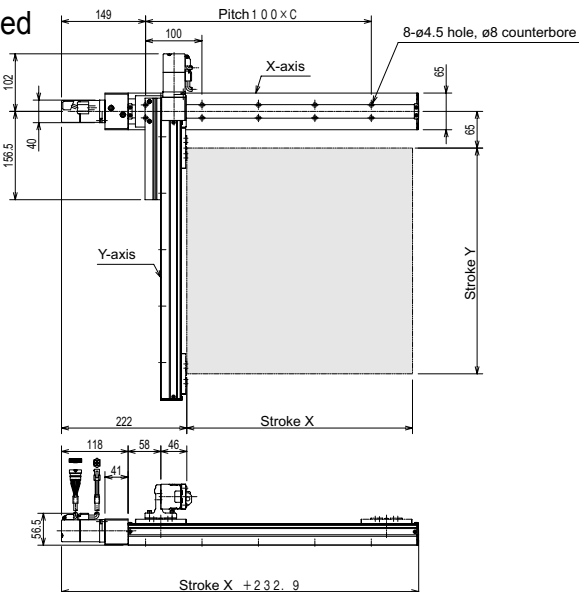

Slider unit

[Set designation]

**BA2 – A1 – A2C R A – 45 40 00 – OF 1 3**

Combined operation	Axis 1 stroke	Axis 2 stroke	Controller	Cable length	
R: Right-handed	15 : 150mm	05 : 50mm	0: None	3 : 3m	9 : 9m
L: Left-handed	95 : 950mm A5 : 1050mm	40 : 400mm	1: CA20-M10 2: CA10-M00B 3: CA10-M01B	5 : 5m	B : 11m D : 13m

**Ball screw type**

- X-axis: Ball screw driven  
Motor straight
- Y-axis: Ball screw driven  
Motor straight

[Specifications]

	X-axis	Y-axis
Type of axis	BB10E-ST-S20N-□5	BB07D-ST-M12N-□□
Stroke (in increments of 100 mm)	150 ~ 1050mm	50 ~ 400mm
Maximum speed	1,200 mm/s (Note 1)	800mm/s
Positioning repeatability (mm)	±0.01mm	±0.02mm
Lead of ball screw	20mm	12mm
Motor output	100W	50W
Resolution	0.01mm	

Acceleration/deceleration time when the maximum speed is set: 0.36 sec. or over

Note 1: When the stroke is as given below, the maximum speed differs.

	Stroke (mm)	Maximum speed (mm/s)
X-axis	750	1000
	850	800
	950 ~ 1050	600

Maximum Payload (kg)	Y-axis stroke							
	50mm	100mm	150mm	200mm	250mm	300mm	350mm	400mm
	11.0	11.0	7.0	7.0	3.5	3.5	1.0	1.0

R: Right-handed

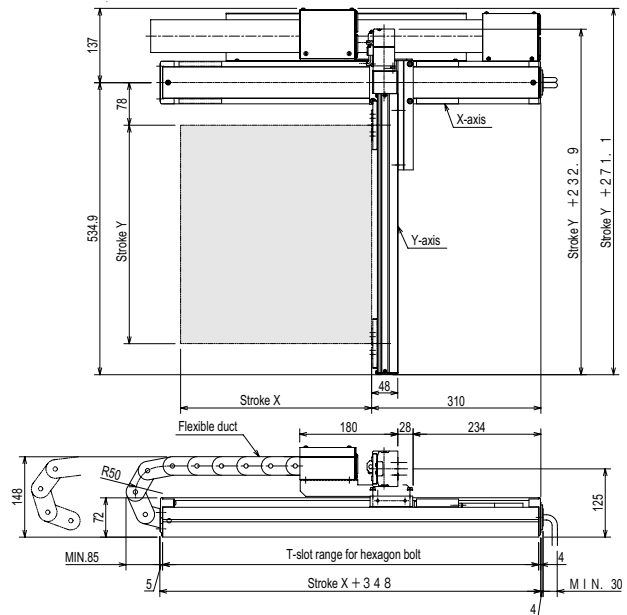
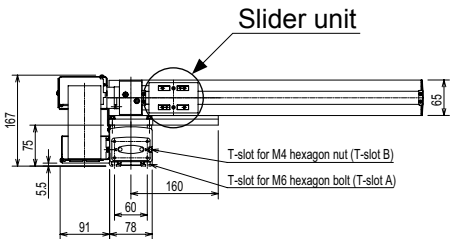
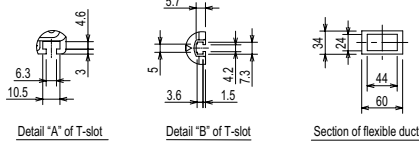

L: Left-handed

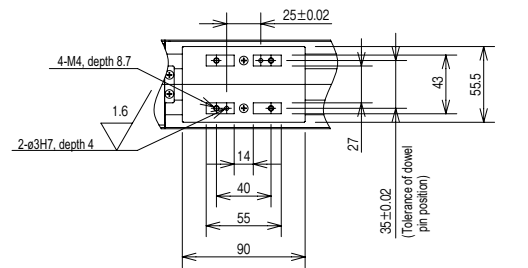
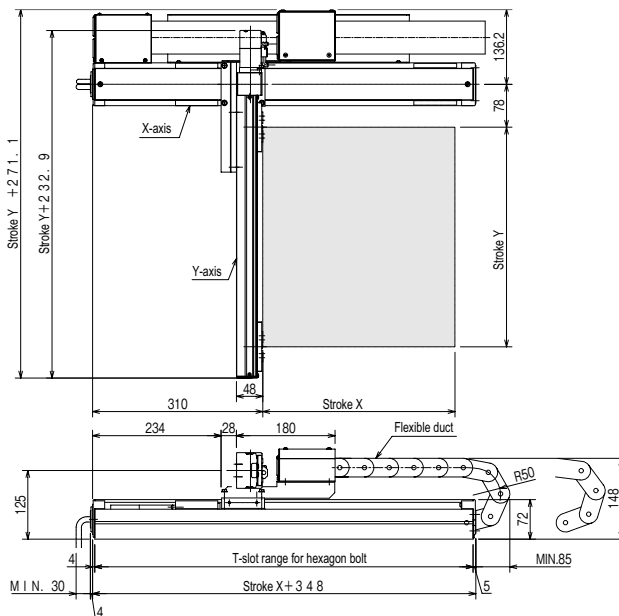

Y-axis slider unit

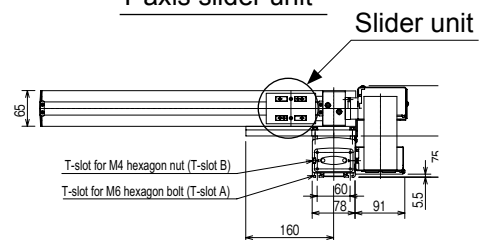

Slider unit

X-Y Flexible-duct Spec.

[Set designation]

**BA2 - A1 - A2A R A - 40 45 00 - OF 1 3**

Combined operation	Axis 1 stroke	Axis 2 stroke	Controller	Cable length
R: Right-handed	10 : 100mm	15 : 150mm	0: None	3 : 3m 9 : 9m
L: Left-handed	90 : 900mm A0 : 1000mm	65 : 650mm	1: CA20-M10 2: CA10-M00B 3: CA10-M01B	5 : 5m B : 11m 7 : 7m D : 13m

**Ball screw type**

X-axis: Ball screw driven  
Motor straight  
Y-axis: Ball screw driven  
Motor straight

[Specifications]

	X-axis	Y-axis
Type of axis	BB10E-ST-M20N- □ 0	BB10E-ST-S20N- □ 5
Stroke (in increments of 100 mm)	100 ~ 1000mm	150 ~ 650mm
Maximum speed	1,200 mm/s (Note 1)	1200mm/s
Positioning repeatability (mm)	±0.01mm	
Lead of ball screw	20mm	20mm
Motor output	100W	100W
Resolution	0.01mm	

Note 1: When the stroke is as given below, the maximum speed differs.

	Stroke (mm)	Maximum speed (mm/s)
X-axis	700	1000
	800	800
	900 ~ 1000	600

Acceleration/deceleration time when the maximum speed is set: 0.36 sec. or over

Maximum Payload (kg)	Y-axis stroke					
	150mm	250mm	350mm	450mm	550mm	650mm
	9.0	8.0	6.5	5.0	3.0	1.0

R: Right-handed

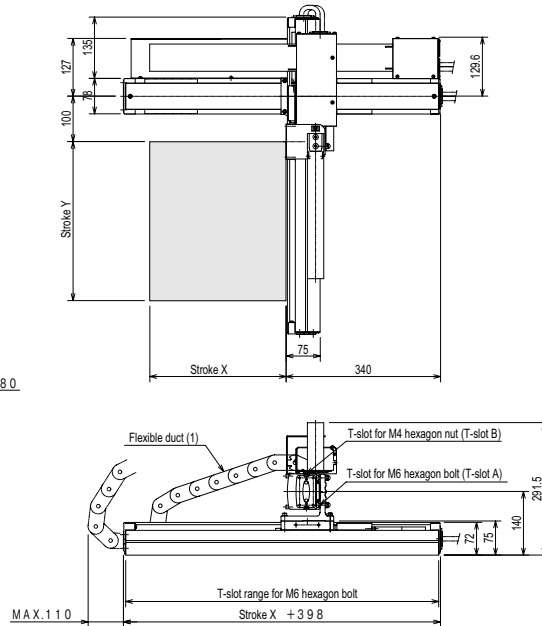
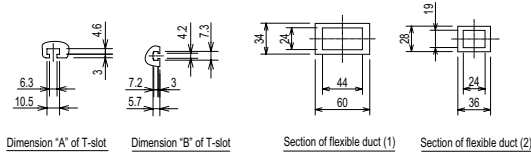

L: Left-handed

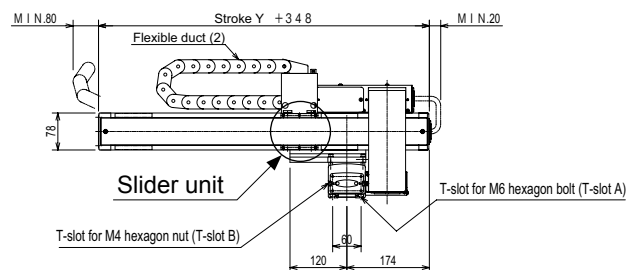
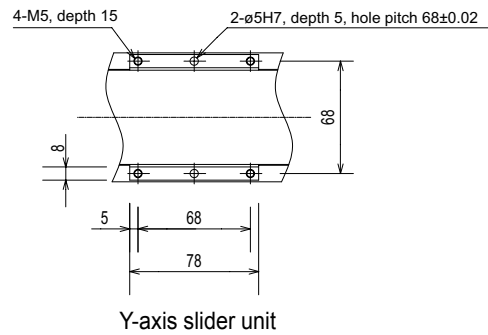
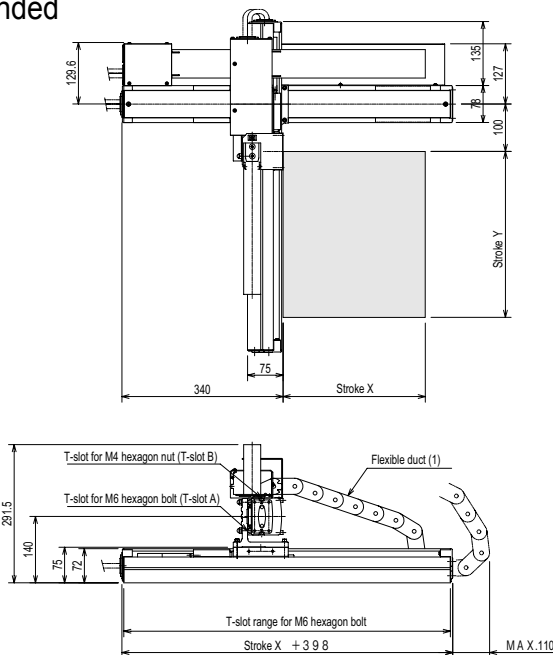

[Set designation]

**BA2 – A1 – A2A R A – 40 45 00 – OT 1 3**

Combined operation R: Right-handed L: Left-handed	Axis 1 stroke 10 : 100mm 90 : 900mm A0 : 1000mm	Axis 2 stroke 15 : 150mm 65 : 650mm	Controller 0: None 1: CA20-M10 2: CA10-M00B 3: CA10-M01B	Cable length 3 : 3m 9 : 9m 5 : 5m B : 11m 7 : 7m D : 13m
---	--	---	--	---

**Ball screw type**

X-axis: Ball screw driven  
Motor straight  
Y-axis: Ball screw driven  
Motor straight

[Specifications]

Type of axis	X-axis: BB10E-ST-M20N-□ 0	Y-axis: BB10E-ST-S20N-□ 5
Stroke (in increments of 100 mm)	100 ~ 1000mm	150 ~ 650mm
Maximum speed	1,200 mm/s (Note 1)	1200mm/s
Positioning repeatability (mm)	±0.01mm	
Lead of ball screw	20mm	20mm
Motor output	100W	100W
Resolution	0.01mm	

Note 1: When the stroke is as given below, the maximum speed differs.

	Stroke (mm)	Maximum speed (mm/s)
X-axis	700	1000
	800	800
	900 ~ 1000	600

Acceleration/deceleration time when the maximum speed is set: 0.36 sec. or over

Maximum Payload (kg)	Y-axis stroke					
	150mm	250mm	350mm	450mm	550mm	650mm
	9.0	8.0	6.5	5.0	3.0	1.0

R: Right-handed

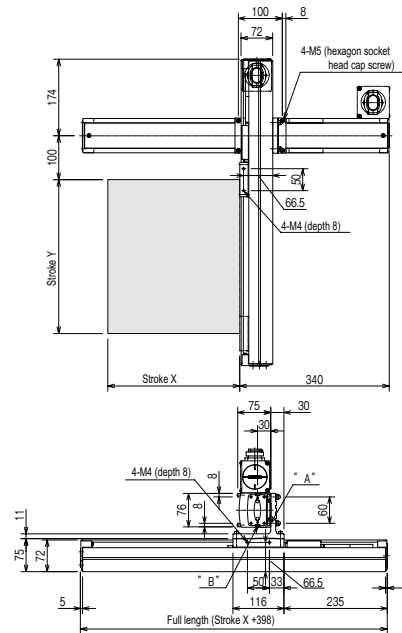
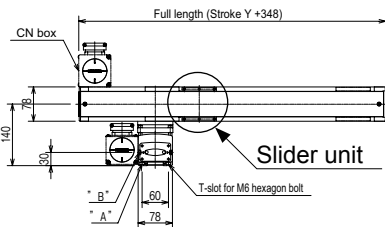
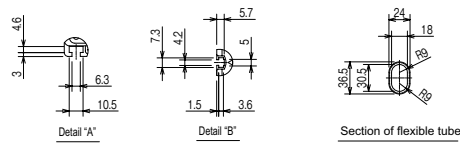

L: Left-handed

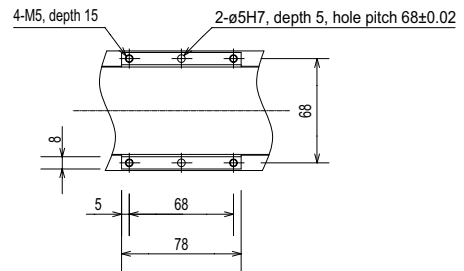
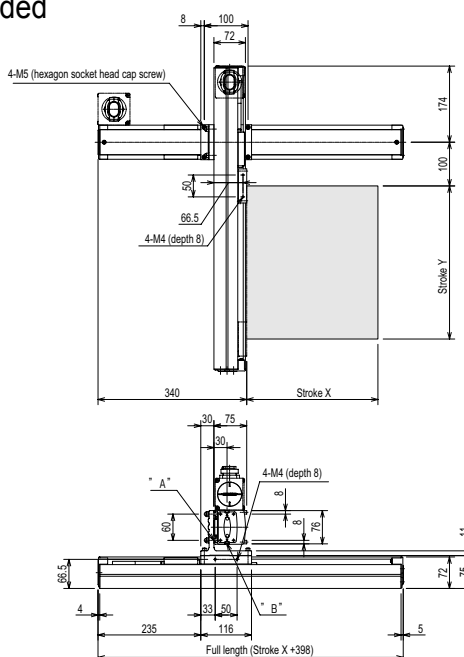

Y-axis slider unit

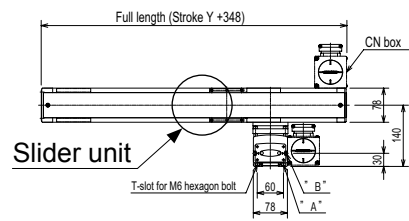

[Set designation]

**BA2 - A1 - A2A R E - 40 45 00 - OF 1 3**

**Ball screw type**

X-axis: Ball screw driven  
Side mounted motor

Y-axis: Ball screw driven  
Side mounted motor

Combined operation	Axis 1 stroke	Axis 2 stroke	Controller	Cable length
R: Right-handed	10 : 100mm	15 : 150mm	0: None	3 : 3m 9 : 9m
L: Left-handed	90 : 900mm	65 : 650mm	1: CA20-M10	5 : 5m B : 11m
	A0 : 1000mm		2: CA10-M00B	7 : 7m D : 13m
			3: CA10-M01B	

[Specifications]

	X-axis	Y-axis
Type of axis	BB10E-U □ -M20N- □ 0	BB10E-U □ -S20N- □ 5
Stroke (in increments of 100 mm)	100 ~ 1000mm	150 ~ 650mm
Maximum speed	1,200 mm/s (Note 1)	1200mm/s
Positioning repeatability (mm)	±0.01mm	
Lead of ball screw	20mm	20mm
Motor output	100W	100W
Resolution	0.01mm	

Note 1: When the stroke is as given below, the maximum speed differs.

	Stroke (mm)	Maximum speed (mm/s)
X-axis	700	1000
	800	800
	900 ~ 1000	600

Acceleration/deceleration time when the maximum speed is set: 0.36 sec. or over

Maximum Payload (kg)	Y-axis stroke					
	150mm	250mm	350mm	450mm	550mm	650mm
	9.0	8.0	6.5	5.0	3.0	1.0

R: Right-handed

Note: When the X-axis stroke is less than 300 mm, no flexible tray is necessary.

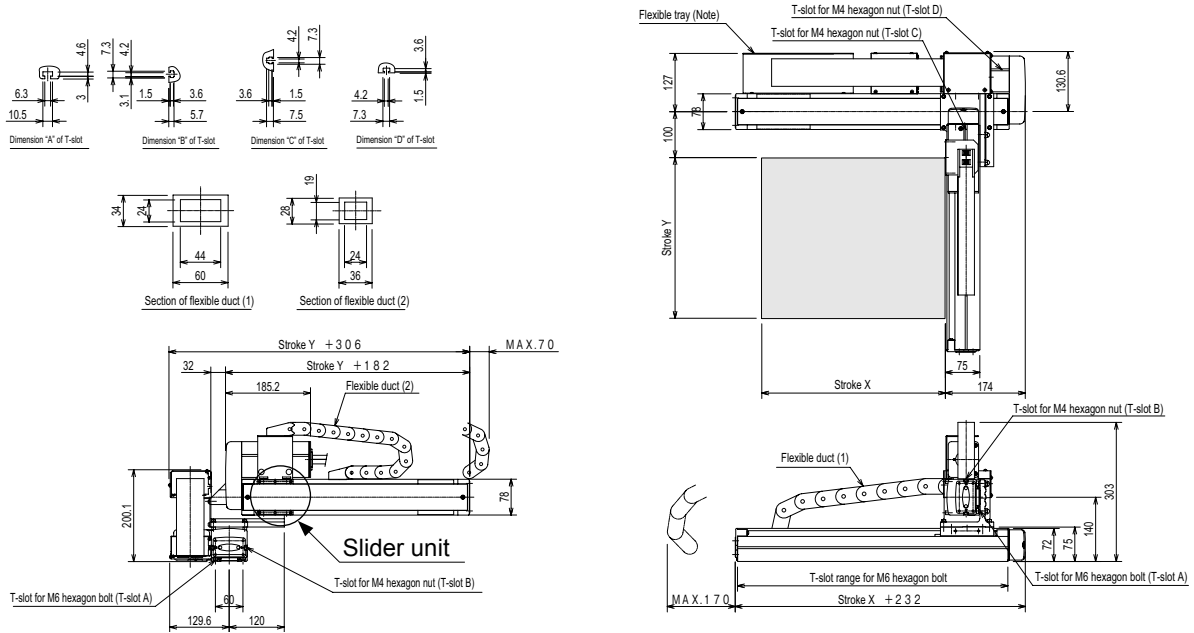

L: Left-handed

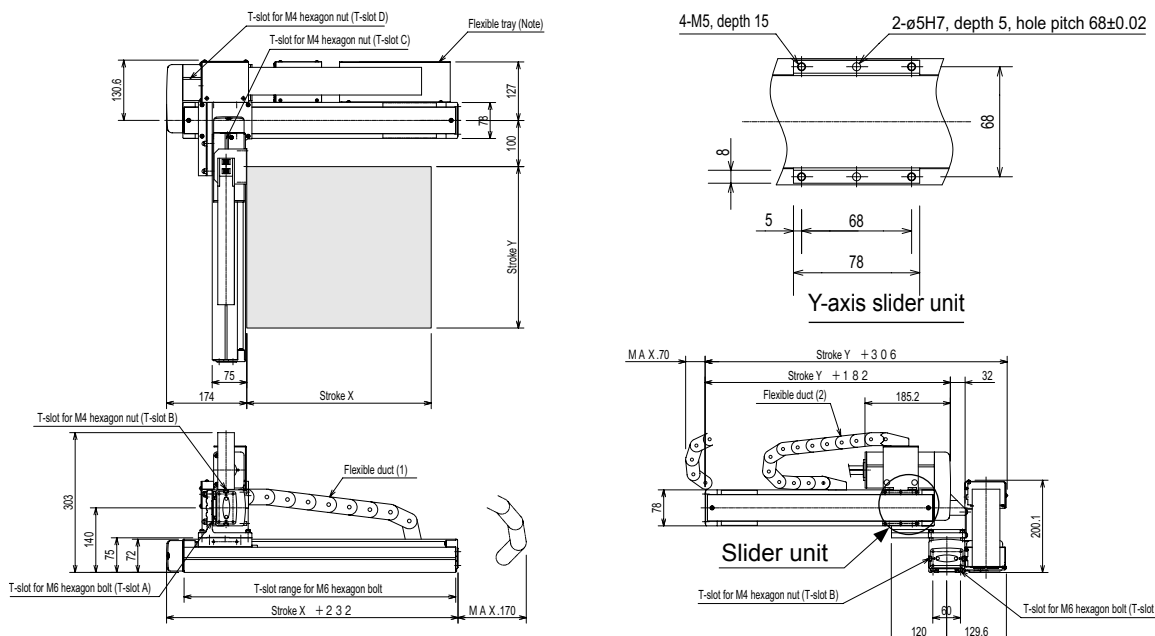



[Set designation]

**BA2 - A1 - A2A R E - 40 45 00 - OT 1 3**

Combined operation	Axis 1 stroke	Axis 2 stroke	Controller	Cable length
R: Right-handed	10 : 100mm	15 : 150mm	0: None	3 : 3m 9 : 9m
L: Left-handed	90 : 900mm	65 : 650mm	1: CA20-M10	5 : 5m B : 11m
	A0 : 1000mm		2: CA10-M00B	7 : 7m D : 13m
			3: CA10-M01B	

**Ball screw type**

X-axis: Ball screw driven  
Side mounted motor

Y-axis: Ball screw driven  
Side mounted motor

[Specifications]

Type of axis	X-axis	Y-axis
Stroke (in increments of 100 mm)	100 ~ 1000mm	150 ~ 650mm
Maximum speed	1,200 mm/s (Note 1)	1200mm/s
Positioning repeatability (mm)	±0.01mm	
Lead of ball screw	20mm	20mm
Motor output	100W	100W
Resolution	0.01mm	

Note 1: When the stroke is as given below, the maximum speed differs.

	Stroke (mm)	Maximum speed (mm/s)
X-axis	700	1000
	800	800
	900 ~ 1000	600

Acceleration/deceleration time when the maximum speed is set: 0.36 sec. or over

Maximum Payload (kg)	Y-axis stroke					
	150mm	250mm	350mm	450mm	550mm	650mm
	9.0	8.0	6.5	5.0	3.0	1.0

R: Right-handed

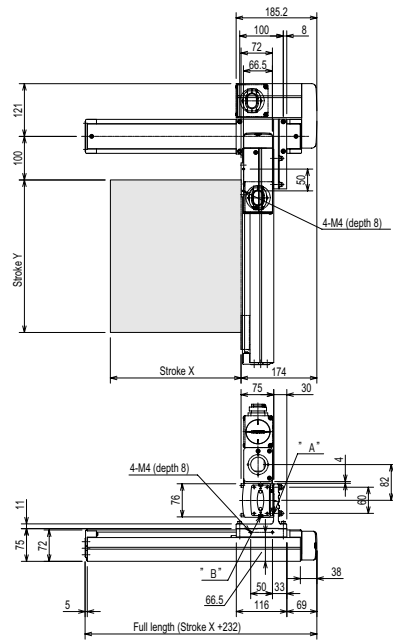
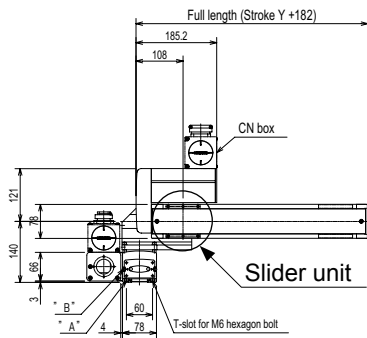
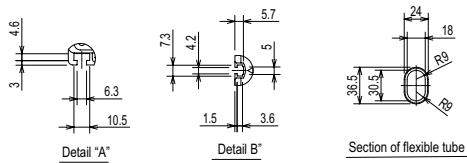

L: Left-handed

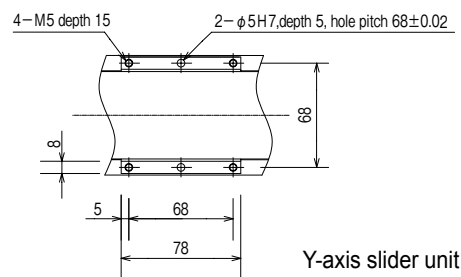
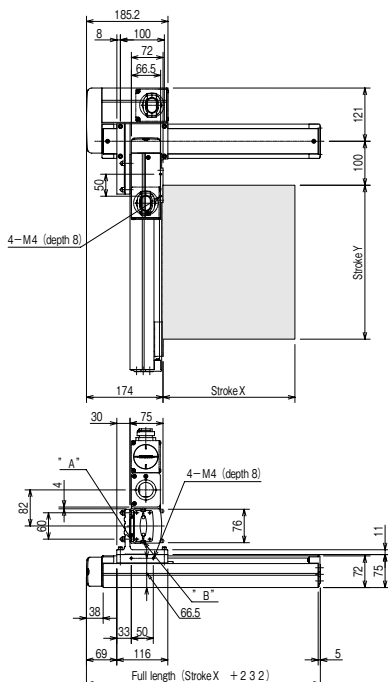

X-Y Flexible-tube Spec., Space-saving type

[Set designation]

**BA2 - A3 - A2A R A - 45 40 00 - OF 1 3**

**Ball screw type**

X-axis: Ball screw driven  
Motor straight

Y-axis: Ball screw driven  
Motor straight

Combined operation	Axis 1 stroke	Axis 2 stroke	Controller	Cable length	
R: Right-handed	15 : 150mm	10 : 100mm	0: None	3 : 3m	9 : 9m
L: Left-handed	7 95 : 950mm A5 : 1050mm	7 80 : 800mm	1: CA20-M10 2: CA10-M00B 3: CA10-M01B	5 : 5m	B : 11m 7 : 7m D : 13m

[Specifications]

	X-axis	Y-axis
Type of axis	BB30E-ST-M20N- □ 5	BB10E-ST-M20N- □ 0
Stroke (in increments of 100 mm)	150 ~ 1050mm	100 ~ 800mm
Maximum speed	1,200 mm/s (Note 1)	1,200 mm/s (Note 1)
Positioning repeatability (mm)	±0.01mm	
Lead of ball screw	20mm	20mm
Motor output	100W	100W
Resolution	0.01mm	

Note 1: When the stroke is as given below, the maximum speed differs.

	Stroke (mm)	Maximum speed (mm/s)
X-axis	750	1000
	850	800
	950 ~ 1050	600
Y-axis	700	1000
	800	800

Acceleration/deceleration time when the maximum speed is set: 0.48 sec. or over

Maximum Payload (kg)	Y-axis stroke							
	100mm	200mm	300mm	400mm	500mm	600mm	700mm	800mm
	13.0	12.0	11.0	10.0	8.0	6.0	3.0	2.0

R: Right-handed

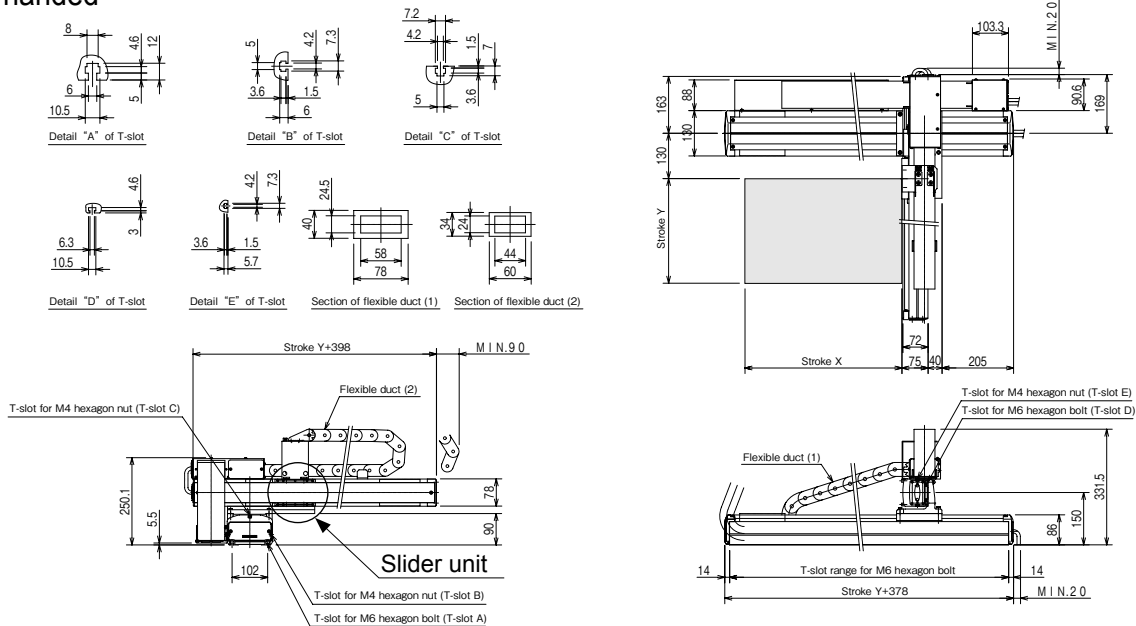

L: Left-handed

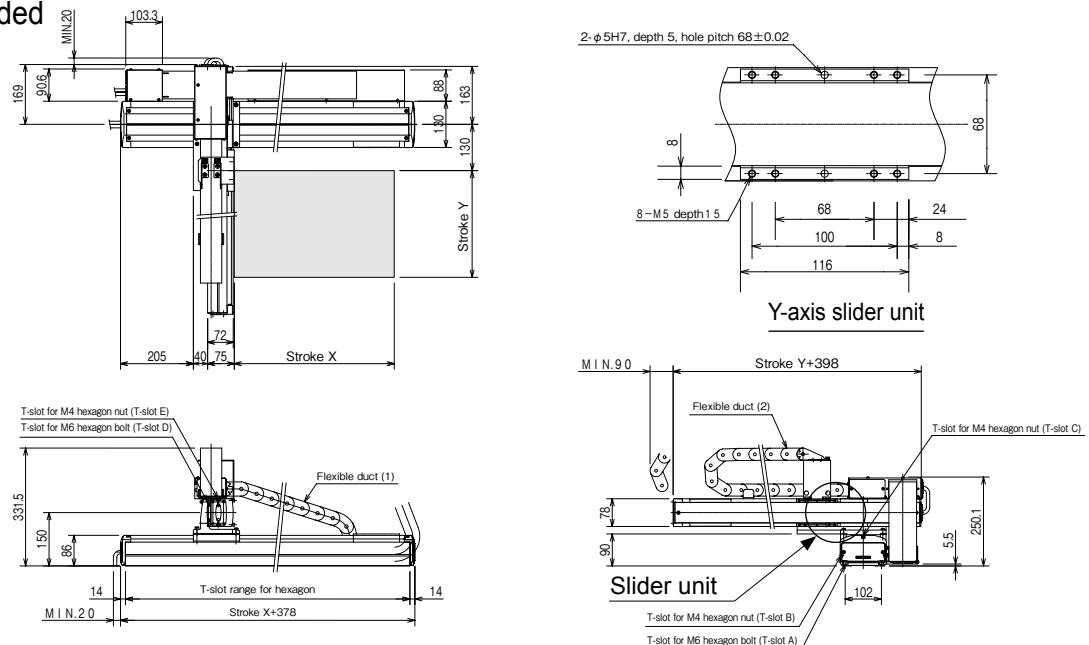

[Set designation]

**BA2 – A3 – A2A R A – 45 40 00 – OT 1 3**

Combined operation R: Right-handed L: Left-handed	Axis 1 stroke 15 : 150mm 95 : 950mm A5 : 1050mm	Axis 2 stroke 10 : 100mm 80 : 800mm	Controller 0: None 1: CA20-M10 2: CA10-M00B 3: CA10-M01B	Cable length 3 : 3m 9 : 9m 5 : 5m B : 11m 7 : 7m D : 13m
---	--	---	--	---

**Ball screw type**

X-axis: Ball screw driven  
Motor straight  
Y-axis: Ball screw driven  
Motor straight

[Specifications]

	X-axis	Y-axis
Type of axis	BB30E-ST-M20N-□ 5	BB10E-ST-M20N-□ 0
Stroke (in increments of 100 mm)	150 ~ 1050mm	100 ~ 800mm
Maximum speed	1,200 mm/s (Note 1)	1,200 mm/s (Note 1)
Positioning repeatability (mm)	±0.01mm	
Lead of ball screw	20mm	20mm
Motor output	100W	100W
Resolution	0.01mm	

Note 1: When the stroke is as given below, the maximum speed differs.

	Stroke (mm)	Maximum speed (mm/s)
X-axis	750	1000
	850	800
	950 ~ 1050	600
Y-axis	700	1000
	800	800

Acceleration/deceleration time when the maximum speed is set: 0.48 sec. or over

Maximum Payload (kg)	Y-axis stroke							
	100mm	200mm	300mm	400mm	500mm	600mm	700mm	800mm
	13.0	12.0	11.0	10.0	8.0	6.0	3.0	2.0

**R: Right-handed**

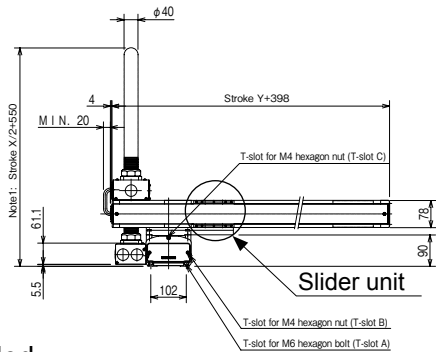
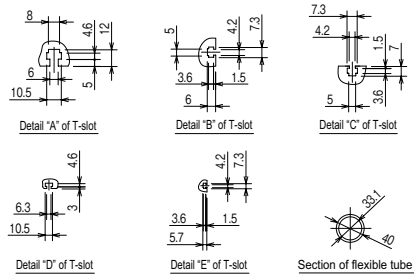

Note 1: The height of the flexible tube is an approximate value.

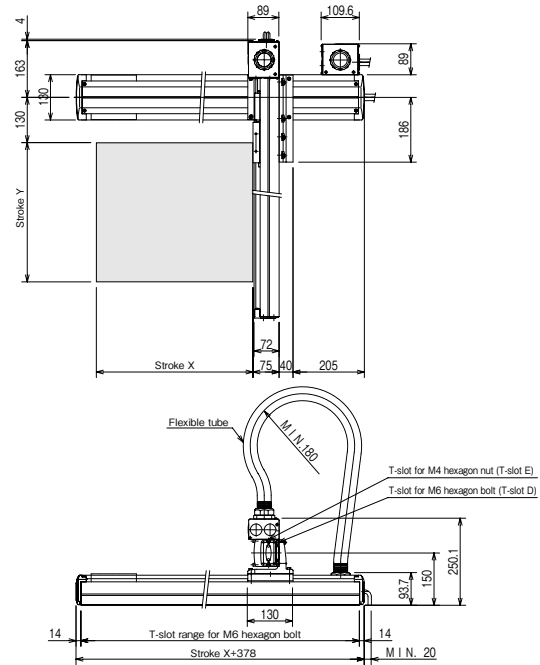

**L: Left-handed**

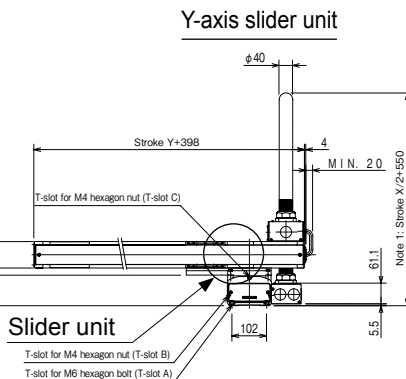
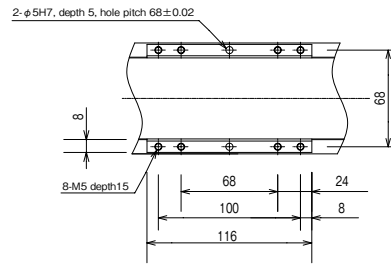
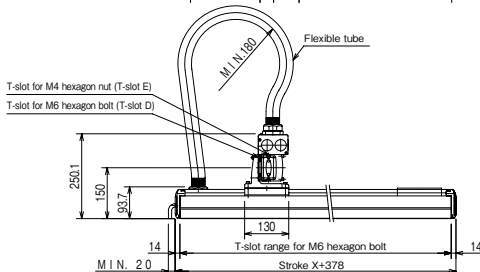
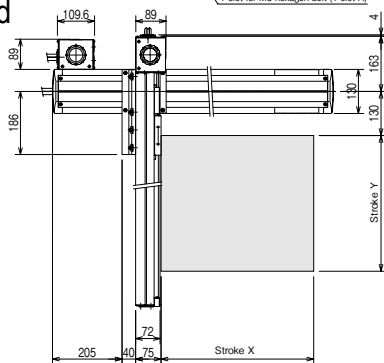

[Set designation]

**BA2 - A3 - A2A R E - 40 40 00 - OF 1 3**

Combined operation	Axis 1 stroke	Axis 2 stroke	Controller	Cable length
R: Right-handed	10 : 100mm	10 : 100mm	0: None	3 : 3m 9 : 9m
L: Left-handed	90 : 900mm A0 : 1000mm	80 : 800mm	1: CA20-M10 2: CA10-M00B 3: CA10-M01B	5 : 5m B : 11m 7 : 7m D : 13m

**Ball screw type**

X-axis: Ball screw driven  
Side mounted motor

Y-axis: Ball screw driven  
Side mounted motor

[Specifications]

	X-axis	Y-axis
Type of axis	BB30E-U □ -M20N- □ 0	BB10E-U □ -M20N- □ 0
Stroke (in increments of 100 mm)	100 ~ 1000mm	100 ~ 800mm
Maximum speed	1,200 mm/s (Note 1)	1,200 mm/s (Note 1)
Positioning repeatability (mm)	±0.01mm	
Lead of ball screw	20mm	20mm
Motor output	100W	100W
Resolution	0.01mm	

Note 1: When the stroke is as given below, the maximum speed differs.

	Stroke (mm)	Maximum speed (mm/s)
X-axis	700	1000
	800	800
	900 ~ 1000	600
Y-axis	700	1000
	800	800

Acceleration/deceleration time when the maximum speed is set: 0.48 sec. or over

Maximum Payload (kg)	Y-axis stroke							
	100mm	200mm	300mm	400mm	500mm	600mm	700mm	800mm
	13.0	12.0	11.0	10.0	8.0	6.0	3.0	2.0

**R: Right-handed**

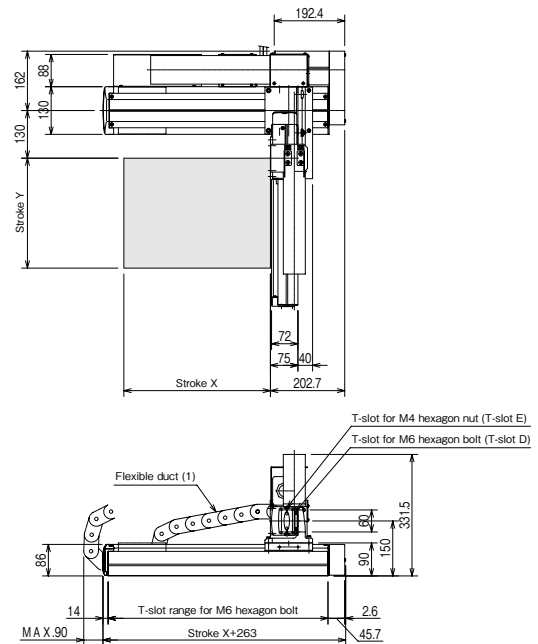
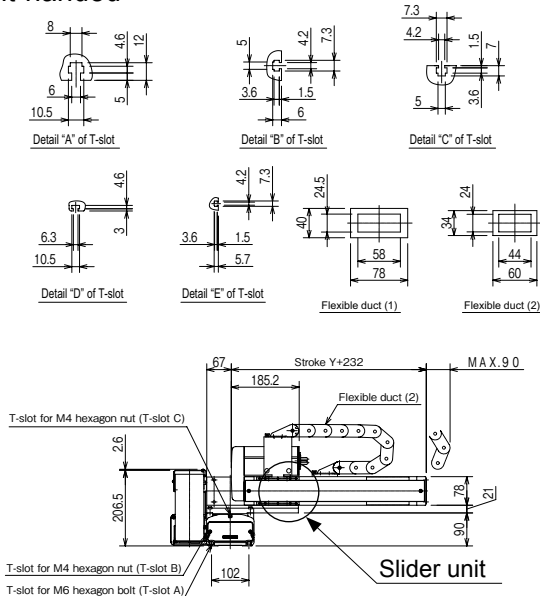

**L: Left-handed**

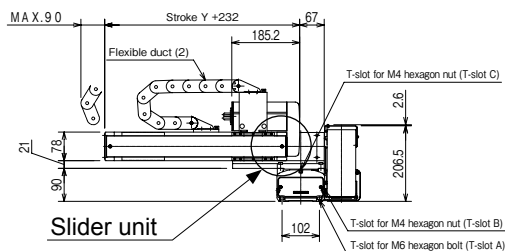
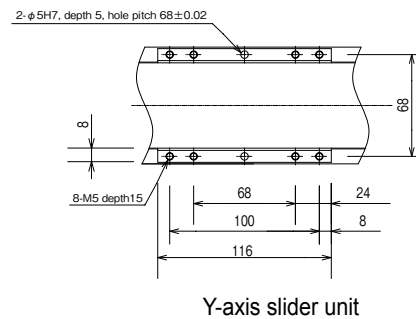
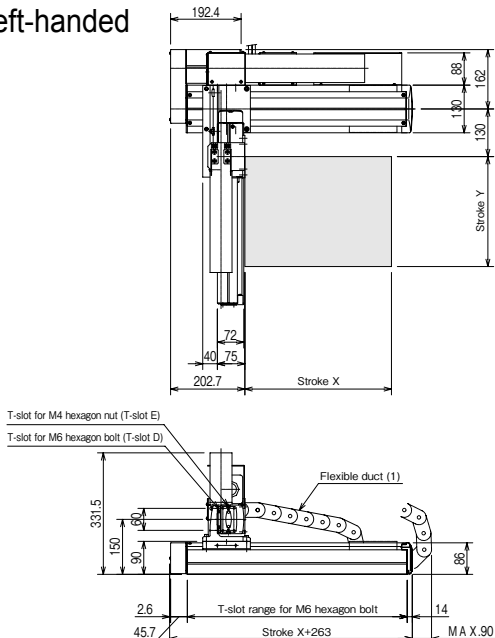

[Set designation]

**BA2 - A3 - A2A R E - 40 40 00 - OT 1 3**

Combined operation	Axis 1 stroke	Axis 2 stroke	Controller	Cable length	
R: Right-handed	10 : 100mm	10 : 100mm	0: None	3 : 3m	9 : 9m
L: Left-handed	90 : 900mm	80 : 800mm	1: CA20-M10	5 : 5m	B : 11m
	A0 : 1000mm		2: CA10-M00B	7 : 7m	D : 13m
			3: CA10-M01B		

### Ball screw type

X-axis: Ball screw driven  
Side mounted motor

Y-axis: Ball screw driven  
Side mounted motor

[Specifications]

	X-axis	Y-axis
Type of axis	BB30E-U □ -M20N- □ 0	BB10E-U □ -M20N- □ 0
Stroke (in increments of 100 mm)	100 ~ 1000mm	100 ~ 800mm
Maximum speed	1,200 mm/s (Note 1)	1,200 mm/s (Note 1)
Positioning repeatability (mm)	±0.01mm	
Lead of ball screw	20mm	20mm
Motor output	100W	100W
Resolution	0.01mm	

Note 1: When the stroke is as given below, the maximum speed differs.

	Stroke (mm)	Maximum speed (mm/s)
X-axis	700	1000
	800	800
	900 ~ 1000	600
Y-axis	700	1000
	800	800

Acceleration/deceleration time when the maximum speed is set: 0.48 sec. or over

Maximum Payload (kg)	Y-axis stroke							
	100mm	200mm	300mm	400mm	500mm	600mm	700mm	800mm
	13.0	12.0	11.0	10.0	8.0	6.0	3.0	2.0

## R: Right-handed

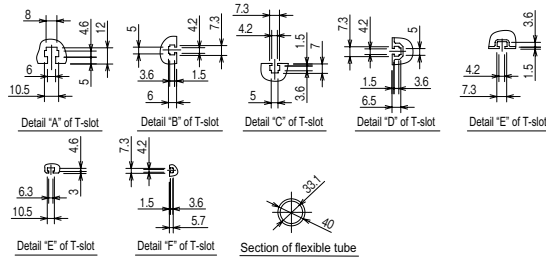

Note 1: The height of the flexible tube is an approximate value.

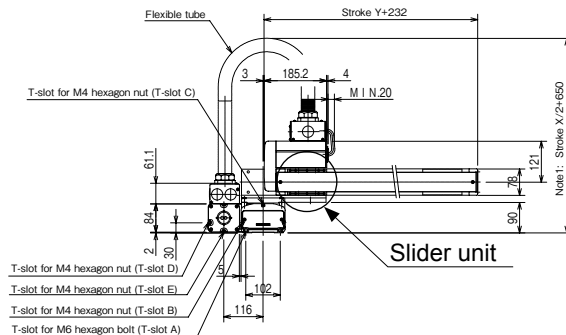
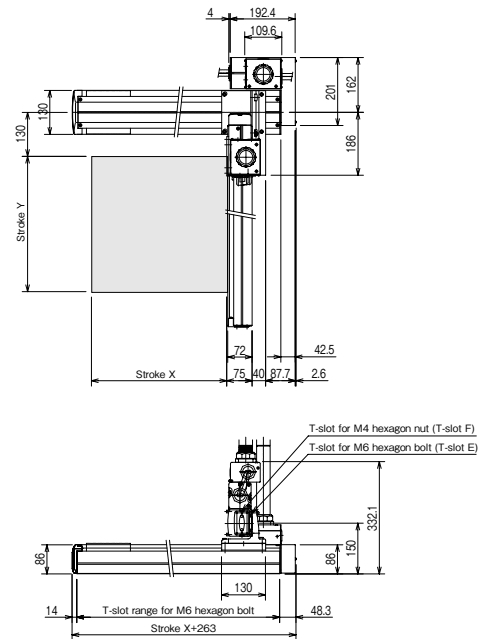

## L: Left-handed

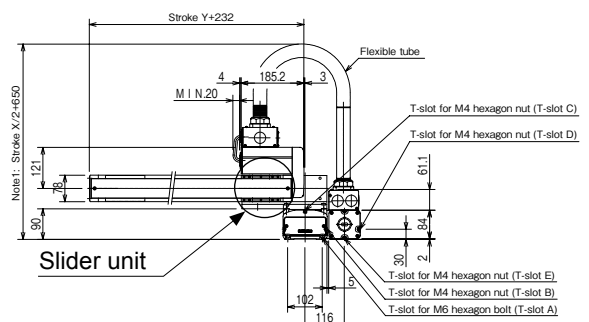
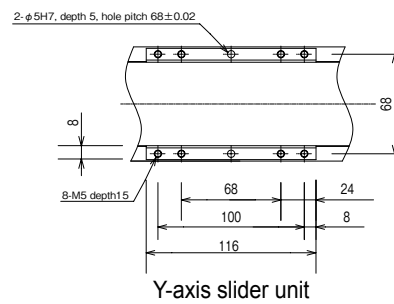
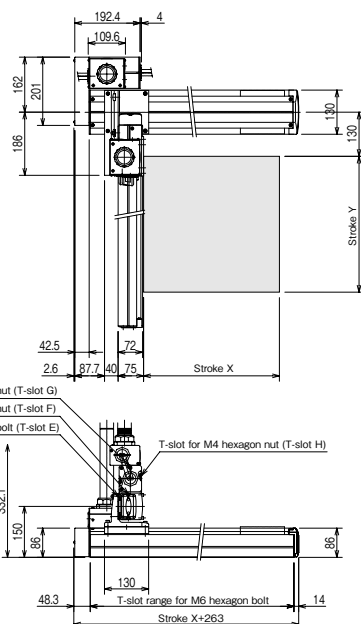

[Set designation]

**BA2 - A3 - A2B R A - 40 40 00 - OF 1 3**

Combined operation	Axis 1 stroke	Axis 2 stroke	Controller	Cable length	
R: Right-handed	10 : 100mm	10 : 100mm	0: None	3 : 3m	9 : 9m
L: Left-handed	90 : 900mm A0 : 1000mm	80 : 800mm	1: CA20-M10 2: CA10-M00B 3: CA10-M01B	5 : 5m	B : 11m D : 13m

**Ball screw type**

X-axis: Ball screw driven  
Motor straight  
Y-axis: Ball screw driven  
Motor straight

[Specifications]

	X-axis	Y-axis
Type of axis	BB30F-ST-M20N-□ 0	BB10E-ST-M20N-□ 0
Stroke (in increments of 100 mm)	100 ~ 1000mm	100 ~ 800mm
Maximum speed	1,200 mm/s (Note 1)	1,200 mm/s (Note 1)
Positioning repeatability (mm)	±0.01mm	
Lead of ball screw	20mm	20mm
Motor output	200W	100W
Resolution	0.01mm	

Acceleration/deceleration time when the maximum speed is set: 0.36 sec. or over

Note 1: When the stroke is as given below, the maximum speed differs.

	Stroke (mm)	Maximum speed (mm/s)
X-axis	700	1000
	800	800
	900 ~ 1000	600
Y-axis	700	1000
	800	800

Maximum Payload (kg)	Y-axis stroke							
	100mm	200mm	300mm	400mm	500mm	600mm	700mm	800mm
	15.0	15.0	14.0	11.0	8.0	6.0	4.0	2.0

X-Y Flexible-duct Spec.

**R: Right-handed**

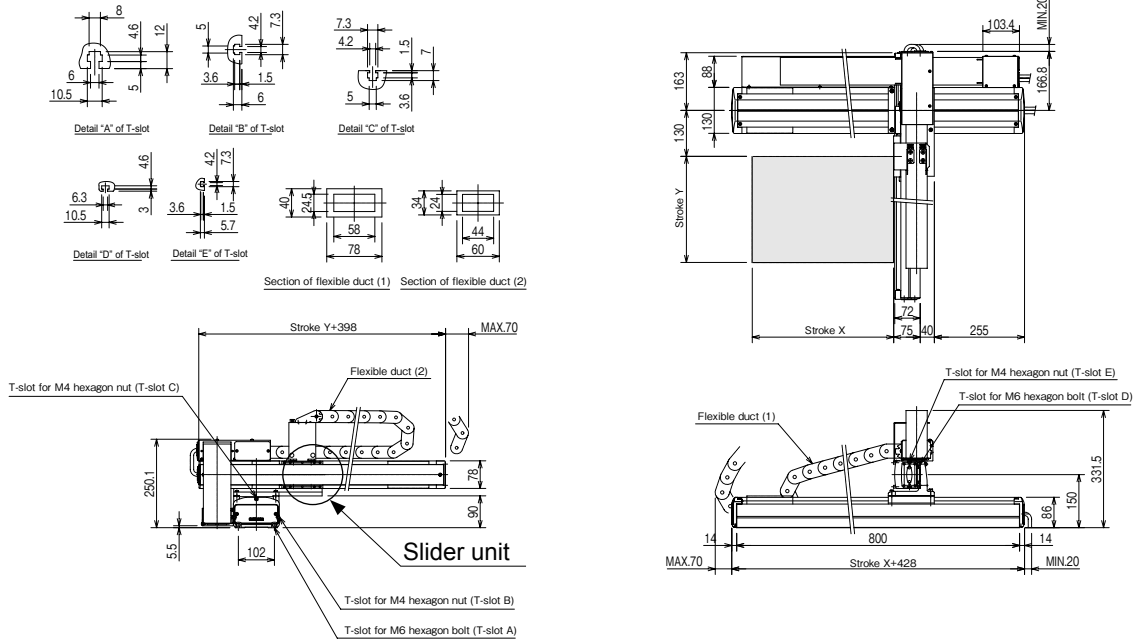

**L: Left-handed**

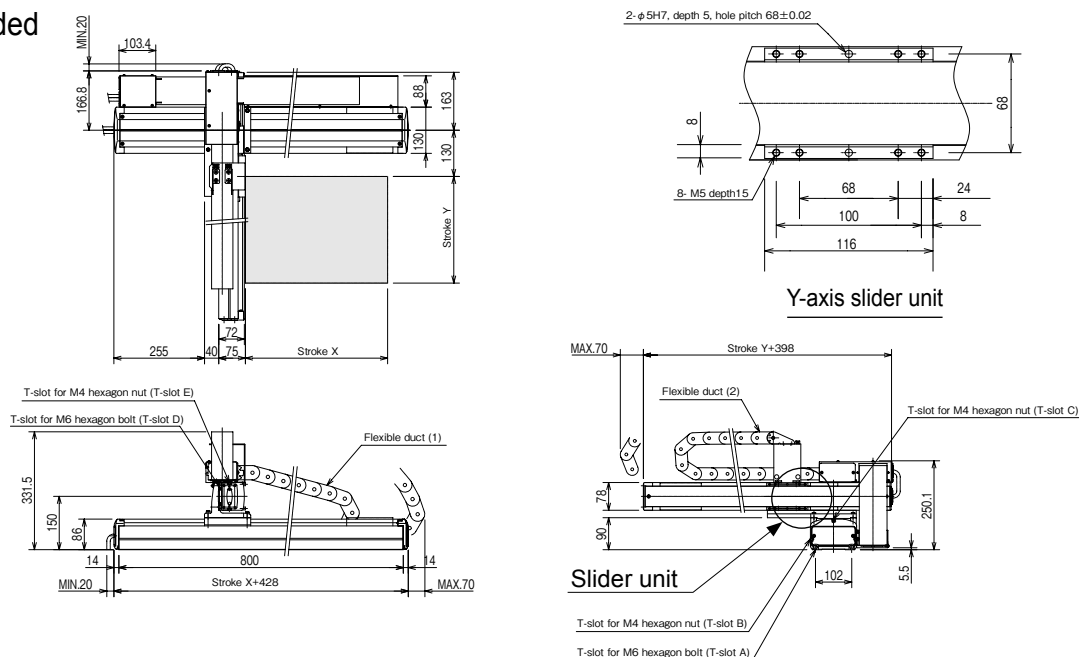

[Set designation]

**BA2 – A3 – A2B R A – 40 40 00 – OT 1 3**

Ball screw type

X-axis: Ball screw driven  
Motor straight  
Y-axis: Ball screw driven  
Motor straight

Combined operation	Axis 1 stroke	Axis 2 stroke	Controller	Cable length
R: Right-handed	10 : 100mm	10 : 100mm	0: None	3 : 3m 9 : 9m
L: Left-handed	90 : 900mm	80 : 800mm	1: CA20-M10	5 : 5m B : 11m
	A0 : 1000mm		2: CA10-M00B	7 : 7m D : 13m
			3: CA10-M01B	

[Specifications]

	X-axis	Y-axis
Type of axis	BB30F-ST-M20N- □ 0	BB10E-ST-M20N- □ 0
Stroke (in increments of 100 mm)	100 ~ 1000mm	100 ~ 800mm
Maximum speed	1,200 mm/s (Note 1)	1,200 mm/s (Note 1)
Positioning repeatability (mm)	±0.01mm	
Lead of ball screw	20mm	20mm
Motor output	200W	100W
Resolution	0.01mm	

Note 1: When the stroke is as given below, the maximum speed differs.

	Stroke (mm)	Maximum speed (mm/s)
X-axis	700	1000
	800	800
	900 ~ 1000	600
Y-axis	700	1000
	800	800

Acceleration/deceleration time when the maximum speed is set: 0.36 sec. or over

Maximum Payload (kg)	Y-axis stroke							
	100mm	200mm	300mm	400mm	500mm	600mm	700mm	800mm
	15.0	15.0	14.0	11.0	8.0	6.0	4.0	2.0

R: Right-handed

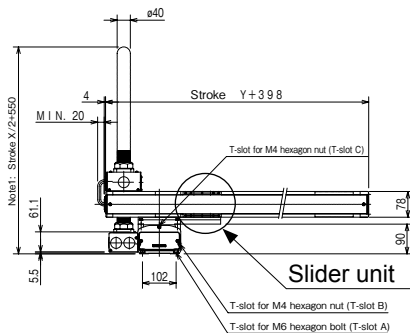
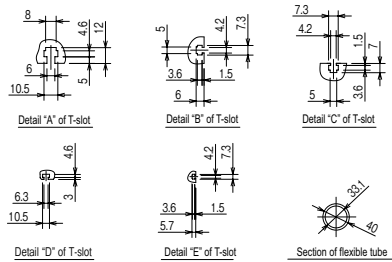

Note 1: The height of the flexible tube is an approximate value.

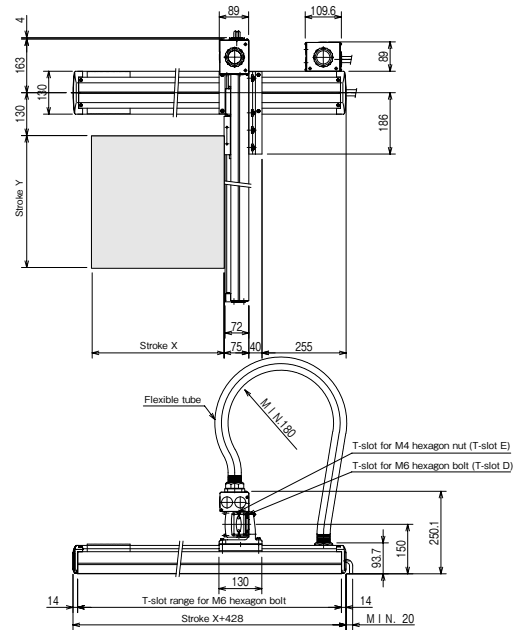

L: Left-handed

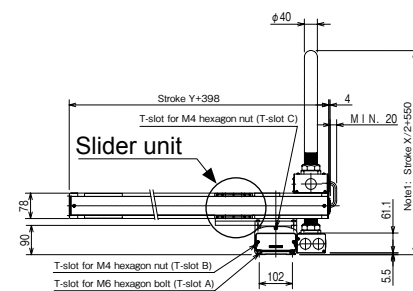
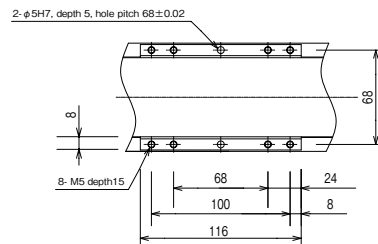
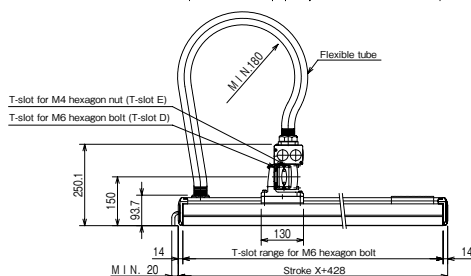
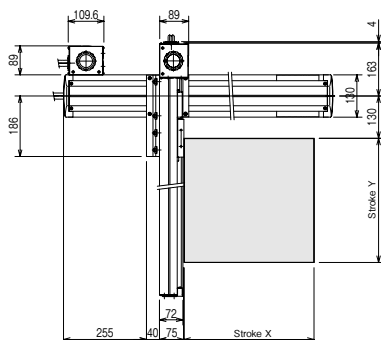

[Set designation]

**BA2 - A3 - A2B R E - 40 40 00 - OF 1 3**

Combined operation	Axis 1 stroke	Axis 2 stroke	Controller	Cable length	
R: Right-handed L: Left-handed	10 : 100mm 90 : 900mm A0 : 1000mm	10 : 100mm 80 : 800mm	0: None 1: CA20-M10 2: CA10-M00B 3: CA10-M01B	3 : 3m 5 : 5m 7 : 7m	9 : 9m B : 11m D : 13m

**Ball screw type**

X-axis: Ball screw driven  
Side mounted motor  
  
Y-axis: Ball screw driven  
Side mounted motor

[Specifications]

	X-axis	Y-axis
Type of axis	BB30F-U □ -M20N- □ 0	BB10E-U □ -M20N- □ 0
Stroke (in increments of 100 mm)	100 ~ 1000mm	100 ~ 800mm
Maximum speed	1,200 mm/s (Note 1)	1,200 mm/s (Note 1)
Positioning repeatability (mm)	±0.01mm	
Lead of ball screw	20mm	20mm
Motor output	200W	100W
Resolution	0.01mm	

Acceleration/deceleration time when the maximum speed is set: 0.36 sec. or over

Note 1: When the stroke is as given below, the maximum speed differs.

	Stroke (mm)	Maximum speed (mm/s)
X-axis	700	1000
	800	800
	900 ~ 1000	600
Y-axis	700	1000
	800	800

Maximum Payload (kg)	Y-axis stroke							
	100mm	200mm	300mm	400mm	500mm	600mm	700mm	800mm
	15.0	15.0	14.0	11.0	8.0	6.0	4.0	2.0

**R: Right-handed**

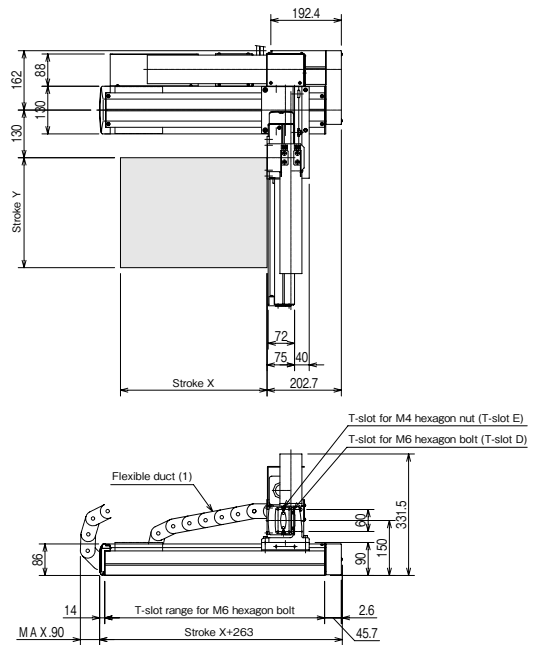
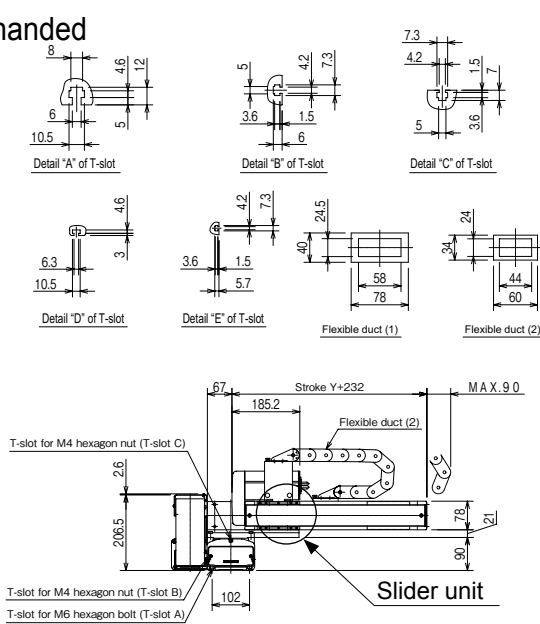

**L: Left-handed**

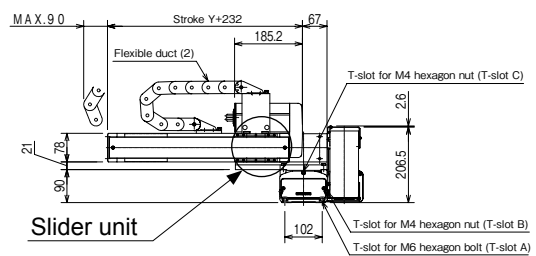
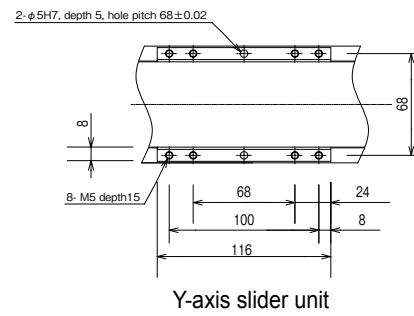
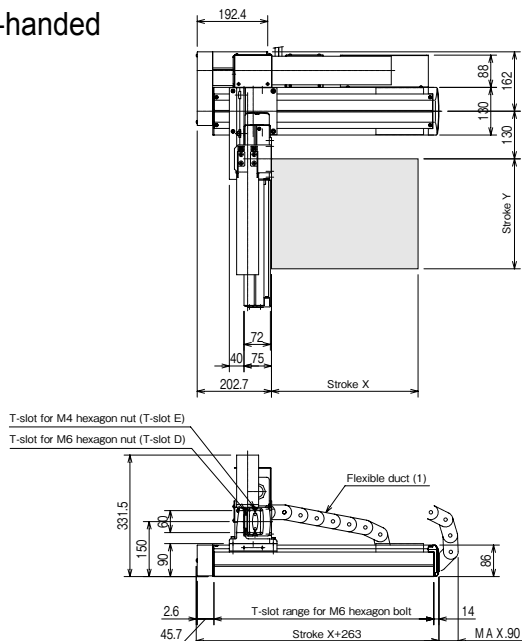

X-Y Flexible-duct Spec., Space-saving type



[Set designation]

**BA2 - A3 - A2B R E - 40 40 00 - OT 1 3**

Combined operation	Axis 1 stroke	Axis 2 stroke	Controller	Cable length	
R: Right-handed	10 : 100mm	10 : 100mm	0: None	3 : 3m	9 : 9m
L: Left-handed	90 : 900mm	80 : 800mm	1: CA20-M10	5 : 5m	B : 11m
	A0 : 1000mm		2: CA10-M00B	7 : 7m	D : 13m
			3: CA10-M01B		

**Ball screw type**

X-axis: Ball screw driven  
Side mounted motor

Y-axis: Ball screw driven  
Side mounted motor

[Specifications]

	X-axis	Y-axis
Type of axis	BB30F-U □ -M20N- □ 0	BB10E-U □ -M20N- □ 0
Stroke (in increments of 100 mm)	100 ~ 1000mm	100 ~ 800mm
Maximum speed	1,200 mm/s (Note 1)	1,200 mm/s (Note 1)
Positioning repeatability (mm)	±0.01mm	
Lead of ball screw	20mm	20mm
Motor output	200W	100W
Resolution	0.01mm	

Note 1: When the stroke is as given below, the maximum speed differs.

	Stroke (mm)	Maximum speed (mm/s)
X-axis	700	1000
	800	800
	900 ~ 1000	600
Y-axis	700	1000
	800	800

Acceleration/deceleration time when the maximum speed is set: 0.36 sec. or over

Maximum Payload (kg)	Y-axis stroke							
	100mm	200mm	300mm	400mm	500mm	600mm	700mm	800mm
	15.0	15.0	14.0	11.0	8.0	6.0	4.0	2.0

R: Right-handed

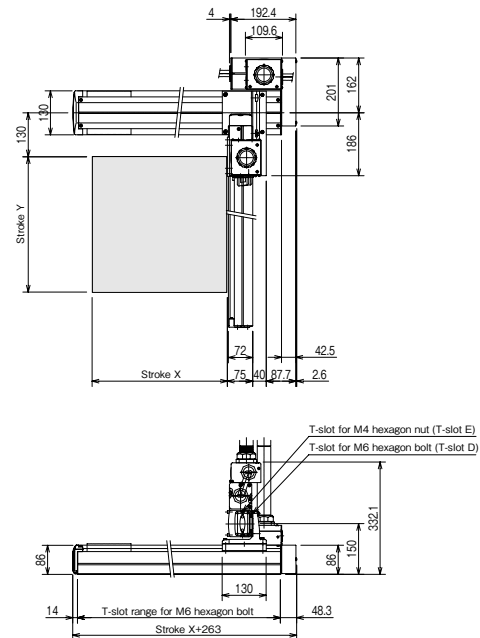
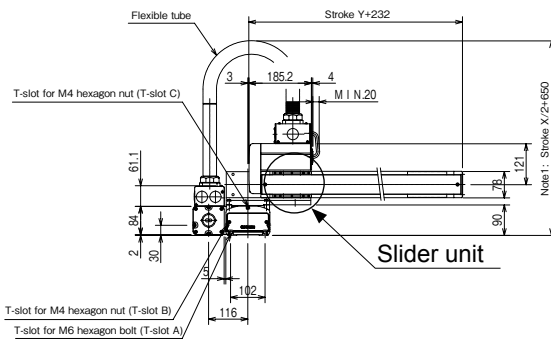
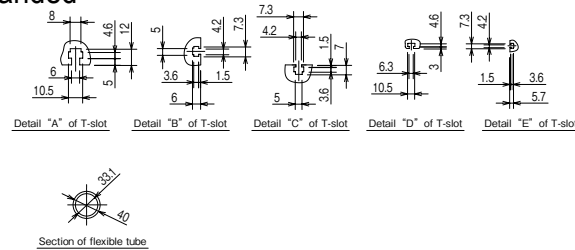

L: Left-handed

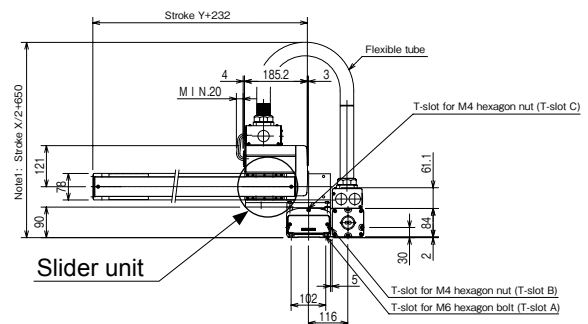
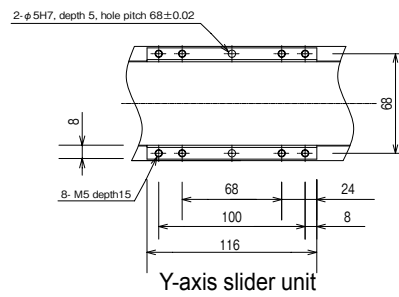
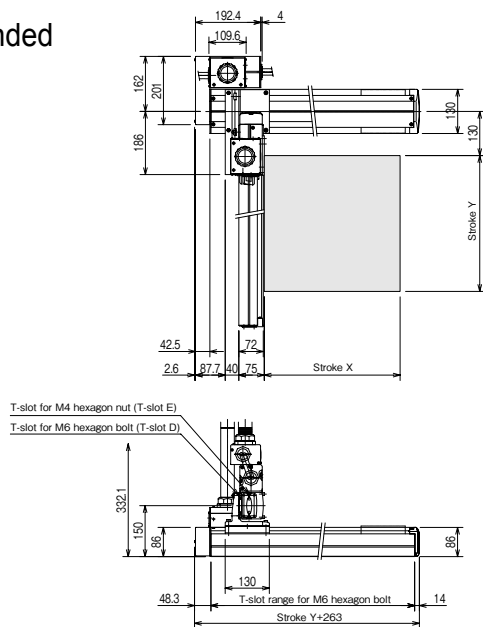

X-Y Flexible-tube Spec., Space-saving type

[Set designation]

**BA2 – A5 – A2A R A – 40 45 00 – OF 1 3**

Combined operation	Axis 1 stroke	Axis 2 stroke	Controller	Cable length
R: Right-handed	20 : 200mm	15 : 150mm	0: None	3 : 3m 9 : 9m
L: Left-handed	90 : 900mm A0 : 1000mm F0 : 1500mm	95 : 950mm A5 : 1050mm	1: CA20-M10 2: CA10-M00B 3: CA10-M01B	5 : 5m B : 11m 7 : 7m D : 13m

**Ball screw type**

X-axis: Ball screw driven  
Motor straight

Y-axis: Ball screw driven  
Motor straight

Note 1: When the stroke is as given below, the maximum speed differs.

[Specifications]

	X-axis	Y-axis
Type of axis	BB50F-ST-M20N- □ 0	BB30E-ST-M20N- □ 5
Stroke (in increments of 100 mm)	200 ~ 1500mm	150 ~ 1050mm
Maximum speed	1,200 mm/s (Note 1)	1,200 mm/s (Note 1)
Positioning repeatability (mm)	±0.01mm	
Lead of ball screw	20mm	20mm
Motor output	200W	100W
Resolution	0.01mm	

Acceleration/deceleration time when the maximum speed is set: 0.36 sec. or over

	Stroke (mm)	Maximum speed (mm/s)
X-axis	700 ~ 800	1100
	900 ~ 1000	1000
	1100 ~ 1200	700
	1300	500
	1400	400
Y-axis	1500	300
	750	1000
	850	800
	950 ~ 1050	600

Maximum Payload (kg)	Y-axis stroke									
	150mm	250mm	350mm	450mm	550mm	650mm	750mm	850mm	950mm	1050mm
	20.0	20.0	20.0	20.0	20.0	20.0	19.0	17.0	14.0	11.0

**R: Right-handed**

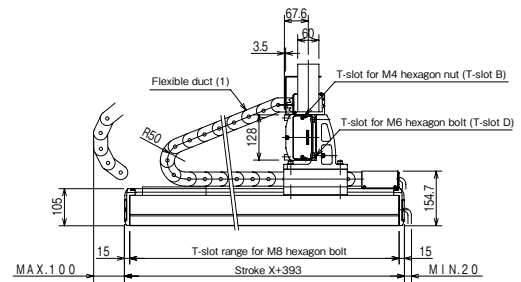
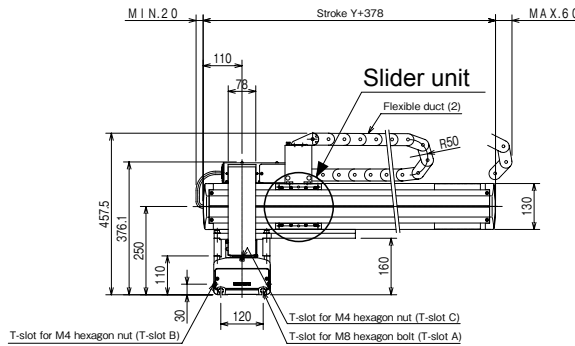
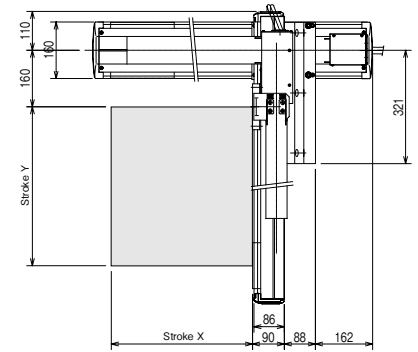
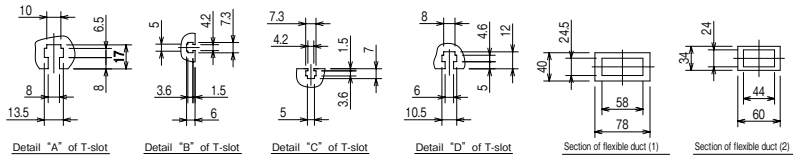

2-φ5H7, depth 6, hole pitch 110±0.02

**L: Left-handed**

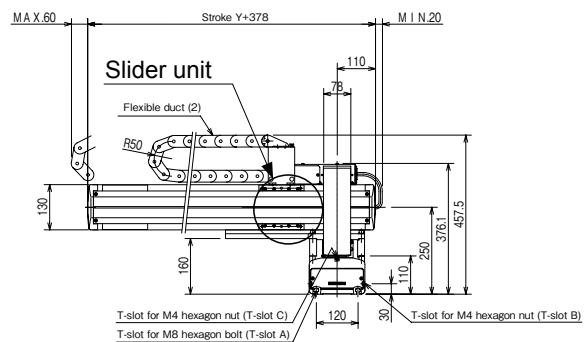
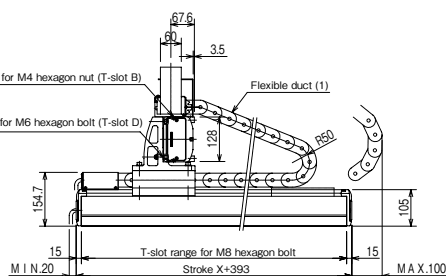
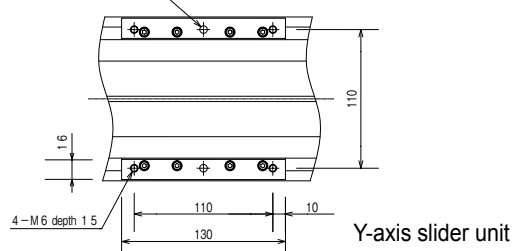
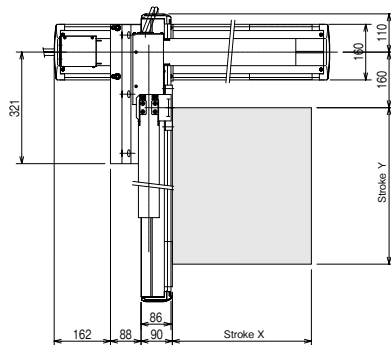

[Set designation]

**BA2 – A5 – A2A R A – 40 45 00 – OT 1 3**

Combined operation	Axis 1 stroke	Axis 2 stroke	Controller	Cable length	
R: Right-handed	20 : 200mm	15 : 150mm	0: None	3 : 3m	9 : 9m
L: Left-handed	90 : 900mm A0 : 1000mm F0 : 1500mm	95 : 950mm A5 : 1050mm	1: CA20-M10 2: CA10-M00B 3: CA10-M01B	5 : 5m	B : 11m D : 13m

**Ball screw type**

X-axis: Ball screw driven  
Motor straight  
Y-axis: Ball screw driven  
Motor straight

Note 1: When the stroke is as given below, the maximum speed differs.

	Stroke (mm)	Maximum speed (mm/s)
X-axis	700 ~ 800	1100
	900 ~ 1000	1000
	1100 ~ 1200	700
	1300	500
	1400	400
Y-axis	1500	300
	750	1000
	850	800
	950 ~ 1050	600

[Specifications]

	X-axis	Y-axis
Type of axis	BB50F-ST-M20N-□ 0	BB30E-ST-M20N-□ 5
Stroke (in increments of 100 mm)	200 ~ 1500mm	150 ~ 1050mm
Maximum speed	1,200 mm/s (Note 1)	1,200 mm/s (Note 1)
Positioning repeatability (mm)	±0.01mm	
Lead of ball screw	20mm	20mm
Motor output	200W	100W
Resolution	0.01mm	

Acceleration/deceleration time when the maximum speed is set: 0.36 sec. or over

Maximum Payload (kg)	Y-axis stroke									
	150mm	250mm	350mm	450mm	550mm	650mm	750mm	850mm	950mm	1050mm
	20.0	20.0	20.0	20.0	20.0	20.0	19.0	17.0	14.0	11.0

**R: Right-handed**

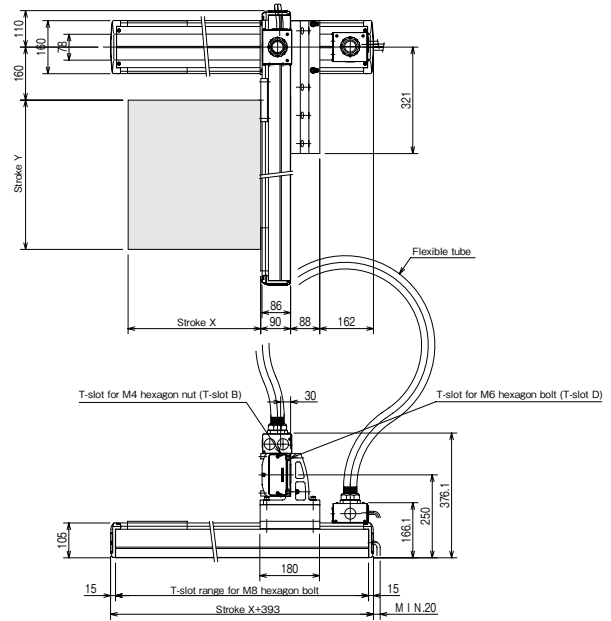
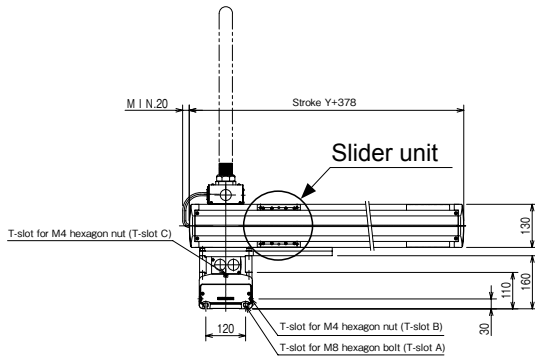
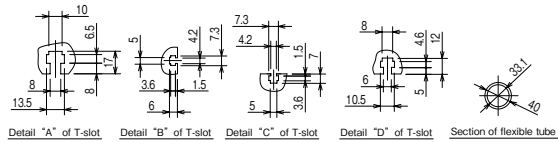

**L: Left-handed**

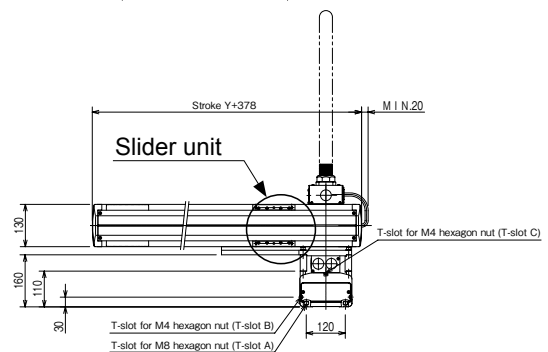
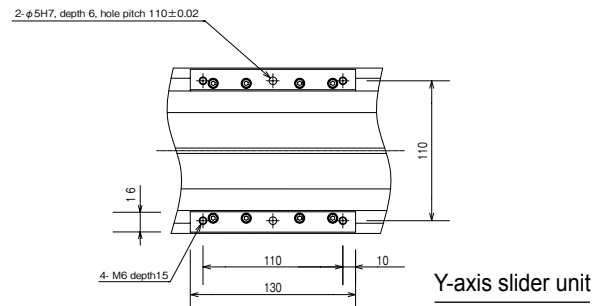
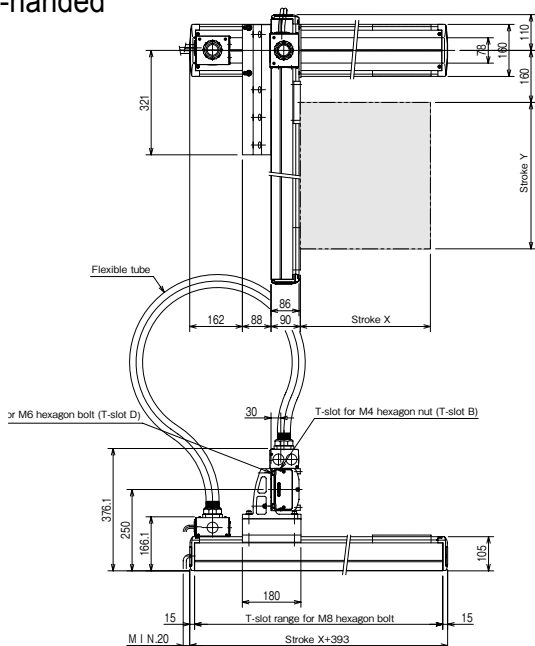

X-Y Flexible-tube Spec.

[Set designation]

**BA2 - A5 - A2A R G - 40 45 00 - OF 1 3**

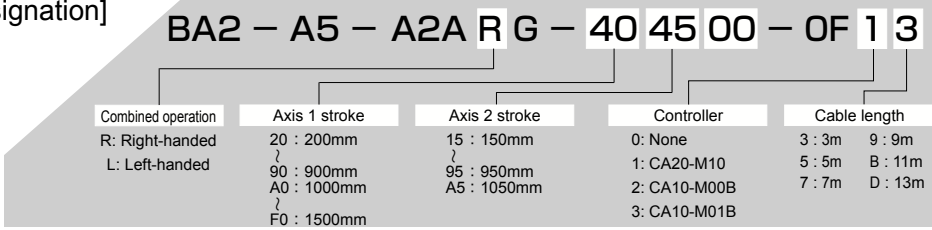

**Ball screw type**

X-axis: Ball screw driven  
Side mounted motor

Y-axis: Ball screw driven  
Motor straight

Note 1: When the stroke is as given below, the maximum speed differs.

[Specifications]

	X-axis	Y-axis
Type of axis	BB50F-U □ -M20N- □ 0	BB30E-ST-M20N- □ 5
Stroke (in increments of 100 mm)	200 ~ 1500mm	150 ~ 1050mm
Maximum speed	1,200 mm/s (Note 1)	1,200 mm/s (Note 1)
Positioning repeatability (mm)	±0.01mm	
Lead of ball screw	20mm	20mm
Motor output	200W	100W
Resolution	0.01mm	

Acceleration/deceleration time when the maximum speed is set: 0.36 sec. or over

	Stroke (mm)	Maximum speed (mm/s)
X-axis	700 ~ 800	1100
	900 ~ 1000	1000
	1100 ~ 1200	700
	1300	500
	1400	400
Y-axis	1500	300
	750	1000
	850	800
	950 ~ 1050	600

Maximum Payload (kg)	Y-axis stroke									
	150mm	250mm	350mm	450mm	550mm	650mm	750mm	850mm	950mm	1050mm
	20.0	20.0	20.0	20.0	20.0	20.0	19.0	17.0	14.0	11.0

**R: Right-handed**

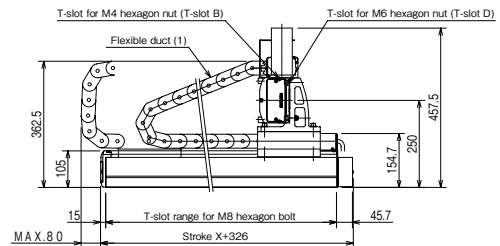
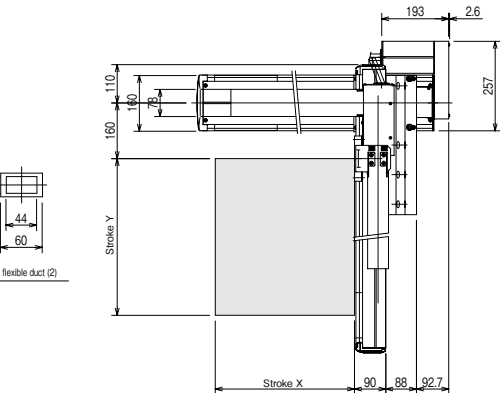
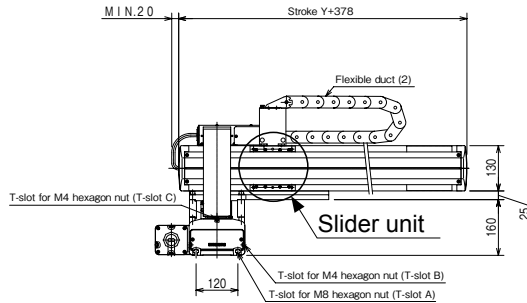
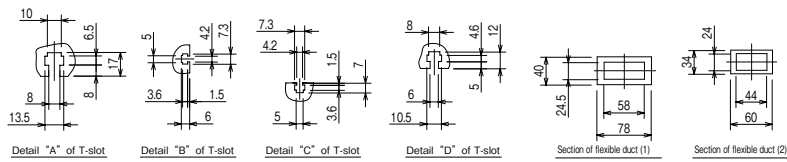

**L: Left-handed**

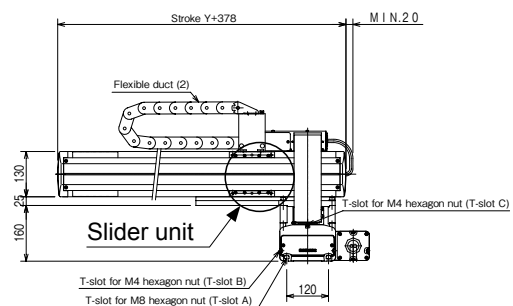
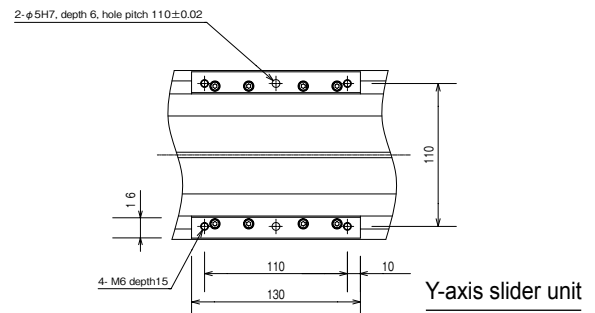
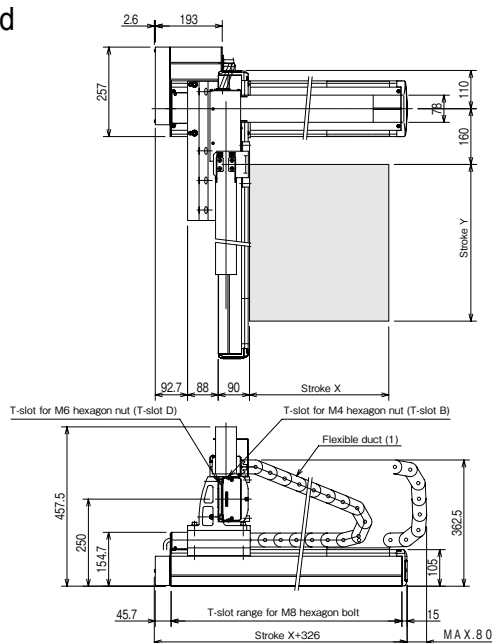

# Orthogonal Axes Specifications

[Set designation]

**BA2 – A5 – A2A R G – 40 45 00 – OT 1 3**

Combined operation	Axis 1 stroke	Axis 2 stroke	Controller	Cable length	
R: Right-handed	20 : 200mm	15 : 150mm	0: None	3 : 3m	9 : 9m
L: Left-handed	90 : 900mm A0 : 1000mm F0 : 1500mm	95 : 950mm A5 : 1050mm	1: CA20-M10 2: CA10-M00B 3: CA10-M01B	5 : 5m	B : 11m D : 13m

## Ball screw type

X-axis: Ball screw driven  
Side mounted motor

Y-axis: Ball screw driven  
Motor straight

Note 1: When the stroke is as given below, the maximum speed differs.

[Specifications]

	X-axis	Y-axis
Type of axis	BB50F-U □ -M20N- □ 0	BB30E-ST-M20N- □ 5
Stroke (in increments of 100 mm)	200 ~ 1500mm	150 ~ 1050mm
Maximum speed	1,200 mm/s (Note 1)	1,200 mm/s (Note 1)
Positioning repeatability (mm)	±0.01mm	
Lead of ball screw	20mm	20mm
Motor output	200W	100W
Resolution	0.01mm	

Acceleration/deceleration time when the maximum speed is set: 0.36 sec. or over

	Stroke (mm)	Maximum speed (mm/s)
X-axis	700 ~ 800	1100
	900 ~ 1000	1000
	1100 ~ 1200	700
	1300	500
	1400	400
Y-axis	1500	300
	750	1000
	850	800
	950 ~ 1050	600

Maximum Payload (kg)	Y-axis stroke									
	150mm	250mm	350mm	450mm	550mm	650mm	750mm	850mm	950mm	1050mm
	20.0	20.0	20.0	20.0	20.0	20.0	19.0	17.0	14.0	11.0

R: Right-handed

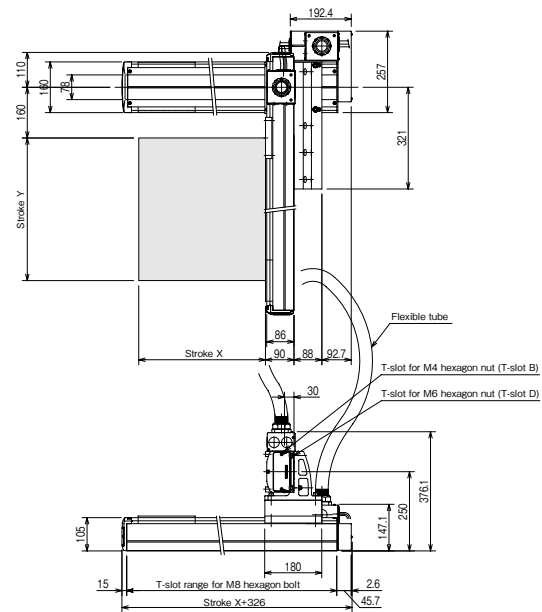
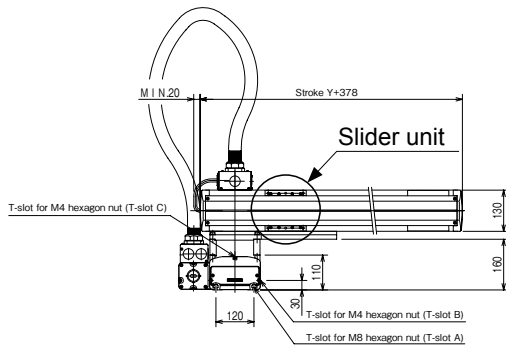
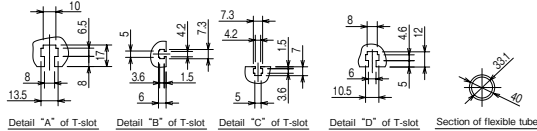

L: Left-handed

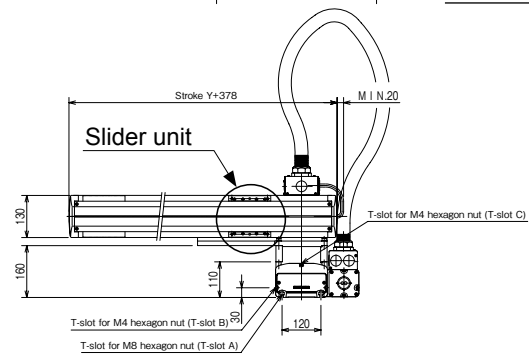
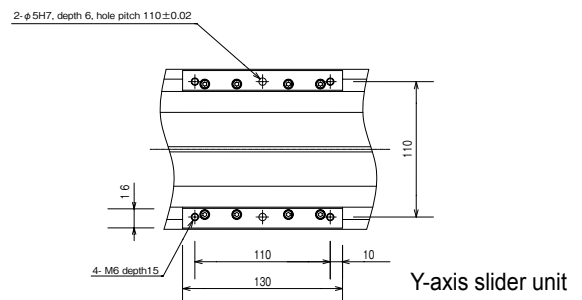
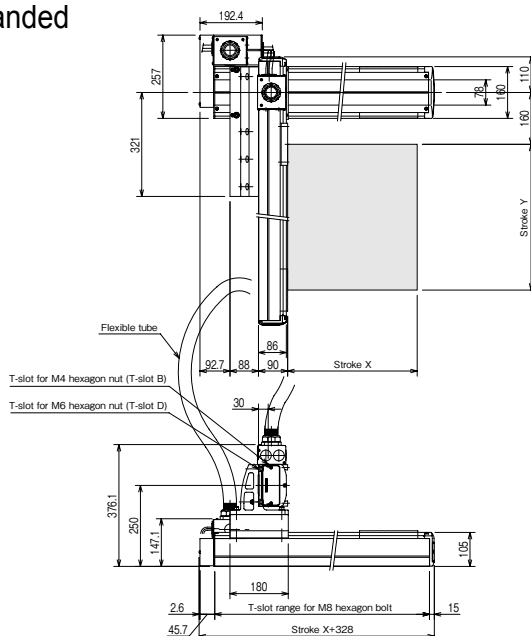

X-Y Flexible-tube Spec., Space-saving type

[Set designation]

**BA2 – A5 – A2B R A – 40 40 00 – OF 1 3**

Combined operation	Axis 1 stroke	Axis 2 stroke	Controller	Cable length	
R: Right-handed	20 : 200mm	10 : 100mm	0: None	3 : 3m	9 : 9m
L: Left-handed	90 : 900mm	90 : 900mm	1: CA20-M10	5 : 5m	B : 11m
	A0 : 1000mm	A0 : 1000mm	2: CA10-M00B	7 : 7m	D : 13m
	F0 : 1500mm		3: CA10-M01B		

**Ball screw type**

X-axis: Ball screw driven  
Motor straight

Y-axis: Ball screw driven  
Motor straight

Note 1: When the stroke is as given below, the maximum speed differs.

[Specifications]

	X-axis	Y-axis
Type of axis	BB50F-ST-M20N-□ 0	BB30F-ST-M20N-□ 0
Stroke (in increments of 100 mm)	200 ~ 1500mm	100 ~ 1000mm
Maximum speed	1,200 mm/s (Note 1)	1,200 mm/s (Note 1)
Positioning repeatability (mm)	±0.01mm	
Lead of ball screw	20mm	20mm
Motor output	200W	200W
Resolution	0.01mm	

Acceleration/deceleration time when the maximum speed is set: 0.36 sec. or over

	Stroke (mm)	Maximum speed (mm/s)
X-axis	700 ~ 800	1100
	900 ~ 1000	1000
	1100 ~ 1200	700
	1300	500
	1400	400
Y-axis	1500	300
	700	1000
	800	800
	900 ~ 1000	600

Maximum Payload (kg)	Y-axis stroke									
	100mm	200mm	300mm	400mm	500mm	600mm	700mm	800mm	900mm	1000mm
	40.0 (31.0)	40.0 (30.0)	33.0 (29.0)	31.0 (28.0)	27.0	23.0	20.0	17.0	14.0	12.0

When the X-axis speed exceeds 1,000 m/s, the values in parentheses are used for the maximum Payload.

R: Right-handed

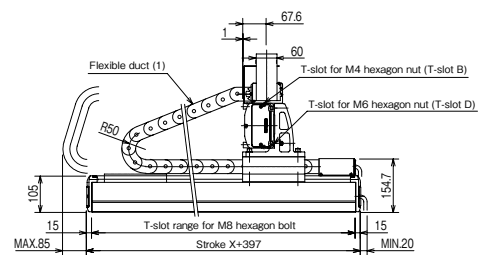
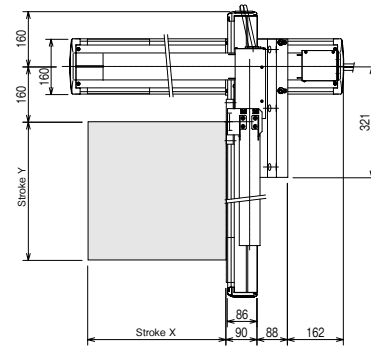
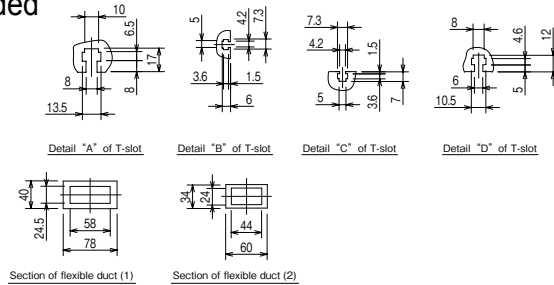

2-φ5H7, depth 6, hole pitch 110±0.02

L: Left-handed

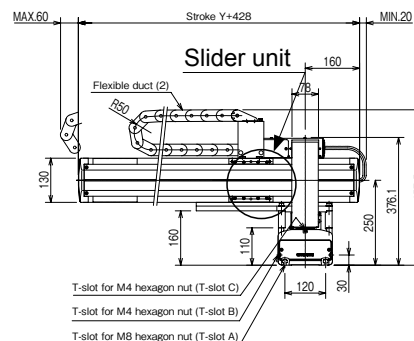
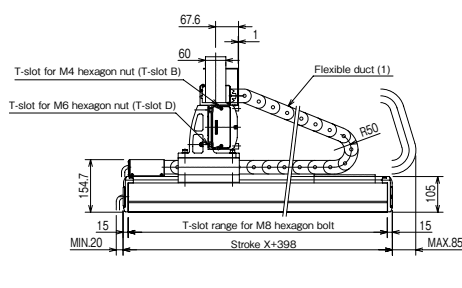
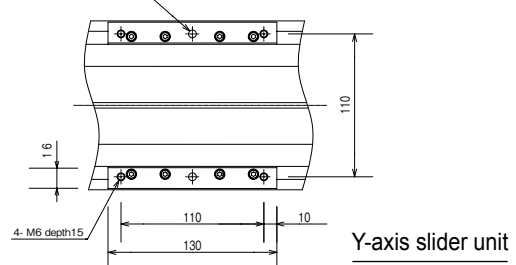
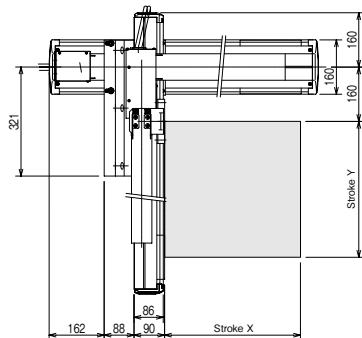

[Set designation]

**BA2 – A5 – A2B R A – 40 40 00 – OT 1 3**

**Ball screw type**

X-axis: Ball screw driven  
Motor straight

Y-axis: Ball screw driven  
Motor straight

Note 1: When the stroke is as given below, the maximum speed differs.

Combined operation	Axis 1 stroke	Axis 2 stroke	Controller	Cable length	
R: Right-handed	20 : 200mm	10 : 100mm	0: None	3 : 3m	9 : 9m
L: Left-handed	90 : 900mm	90 : 900mm	1: CA20-M10	5 : 5m	B : 11m
	A0 : 1000mm	A0 : 1000mm	2: CA10-M00B	7 : 7m	D : 13m
	F0 : 1500mm		3: CA10-M01B		

[Specifications]

	X-axis	Y-axis
Type of axis	BB50F-ST-M20N-□ 0	BB30F-ST-M20N-□ 0
Stroke (in increments of 100 mm)	200 ~ 1500mm	100 ~ 1000mm
Maximum speed	1,200 mm/s (Note 1)	1,200 mm/s (Note 1)
Positioning repeatability (mm)	±0.01mm	
Lead of ball screw	20mm	20mm
Motor output	200W	200W
Resolution	0.01mm	

Acceleration/deceleration time when the maximum speed is set: 0.36 sec. or over

	Stroke (mm)	Maximum speed (mm/s)
X-axis	700 ~ 800	1100
	900 ~ 1000	1000
	1100 ~ 1200	700
	1300	500
	1400	400
Y-axis	700	1000
	800	800
	900 ~ 1000	600

Maximum Payload (kg)	Y-axis stroke									
	100mm	200mm	300mm	400mm	500mm	600mm	700mm	800mm	900mm	1000mm
	40.0 (31.0)	40.0 (30.0)	33.0 (29.0)	31.0 (28.0)	27.0	23.0	20.0	17.0	14.0	12.0

When the X-axis speed exceeds 1,000 m/s, the values in parentheses are used for the maximum Payload.

**R: Right-handed**

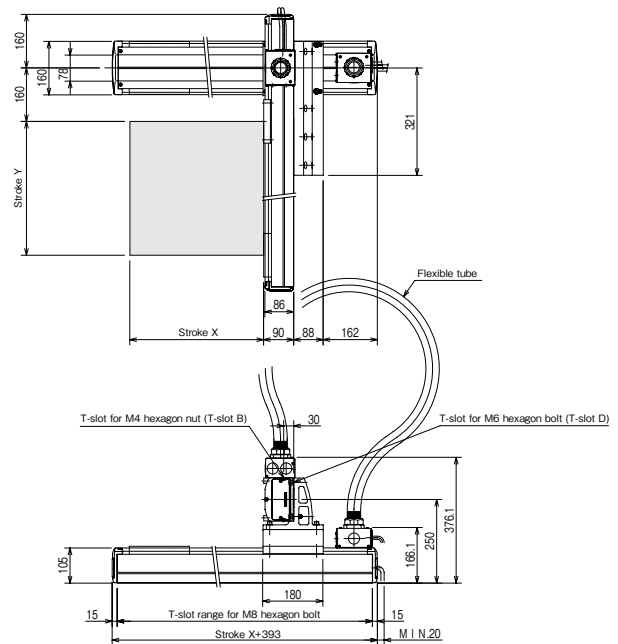
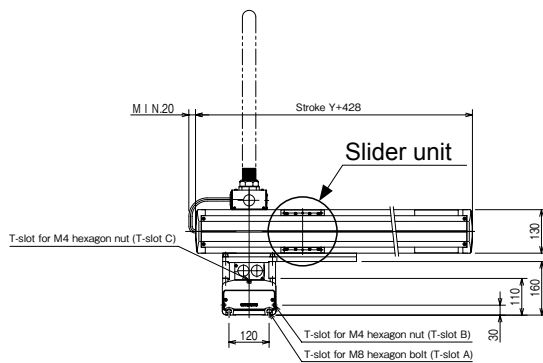
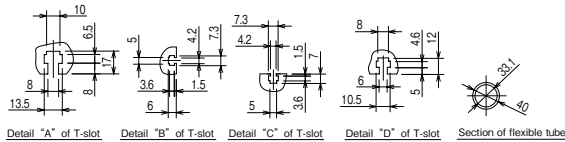

2-φ5H7, depth 6, hole pitch 110±0.02

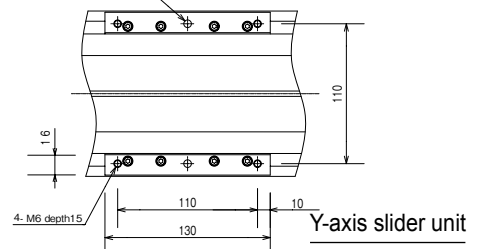

**L: Left-handed**

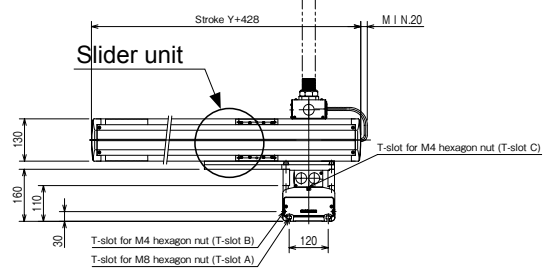
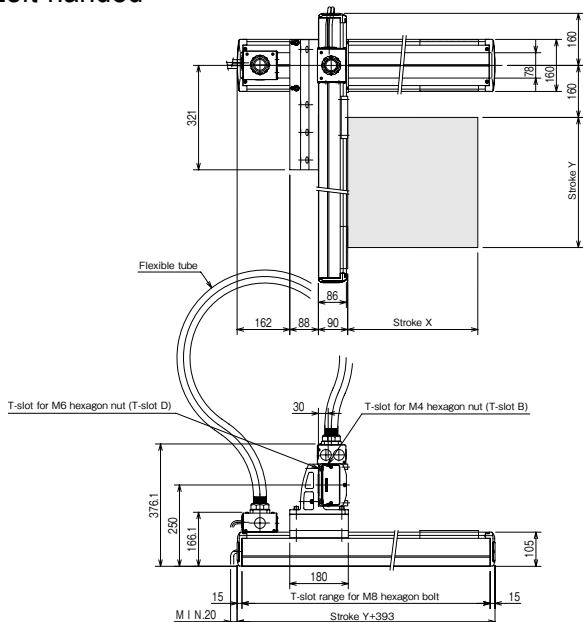

[Set designation]

**BA2 – A5 – A2B R G – 40 40 00 – OF 1 3**

**Ball screw type**

X-axis: Ball screw driven  
Side mounted motor

Y-axis: Ball screw driven  
Motor straight

Note 1: When the stroke is as given below, the maximum speed differs.

Combined operation	Axis 1 stroke	Axis 2 stroke	Controller	Cable length
R: Right-handed	20 : 200mm	10 : 100mm	0: None	3 : 3m 9 : 9m
L: Left-handed	90 : 900mm	90 : 900mm	1: CA20-M10	5 : 5m B : 11m
	A0 : 1000mm	A0 : 1000mm	2: CA10-M00B	7 : 7m D : 13m
	F0 : 1500mm		3: CA10-M01B	

[Specifications]

	X-axis	Y-axis
Type of axis	BB50F-U □ -M20N- □ 0	BB30F-ST-M20N- □ 0
Stroke (in increments of 100 mm)	200 ~ 1500mm	100 ~ 1000mm
Maximum speed	1,200 mm/s (Note 1)	1,200 mm/s (Note 1)
Positioning repeatability (mm)	±0.01mm	
Lead of ball screw	20mm	20mm
Motor output	200W	200W
Resolution	0.01mm	

Acceleration/deceleration time when the maximum speed is set: 0.36 sec. or over

	Stroke (mm)	Maximum speed (mm/s)
X-axis	700 ~ 800	1100
	900 ~ 1000	1000
	1100 ~ 1200	700
	1300	500
	1400	400
Y-axis	1500	300
	700	1000
	800	800
	900 ~ 1000	600

Maximum Payload (kg)	Y-axis stroke									
	100mm	200mm	300mm	400mm	500mm	600mm	700mm	800mm	900mm	1000mm
	40.0 (31.0)	40.0 (30.0)	33.0 (29.0)	31.0 (28.0)	27.0	23.0	20.0	17.0	14.0	12.0

When the X-axis speed exceeds 1,000 m/s, the values in parentheses are used for the maximum Payload.

R: Right-handed

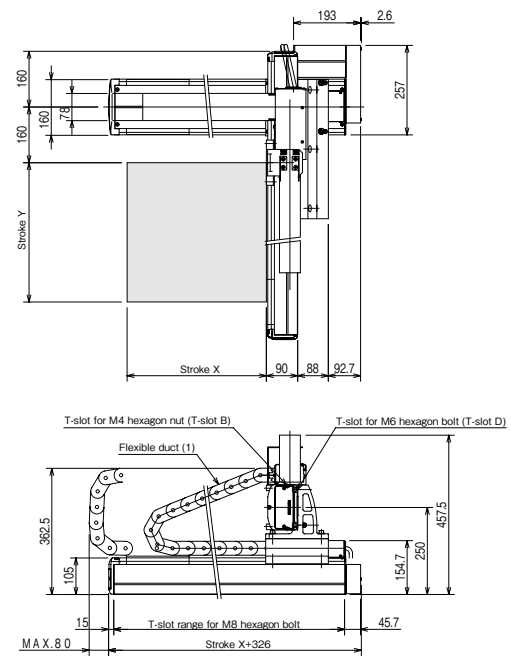
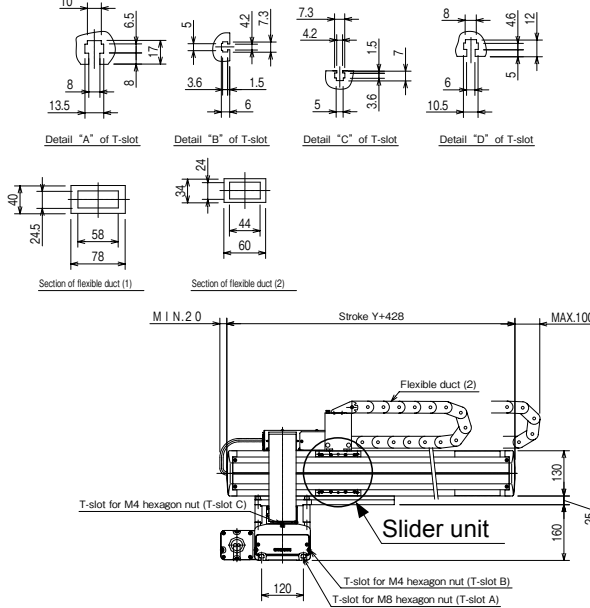

L: Left-handed

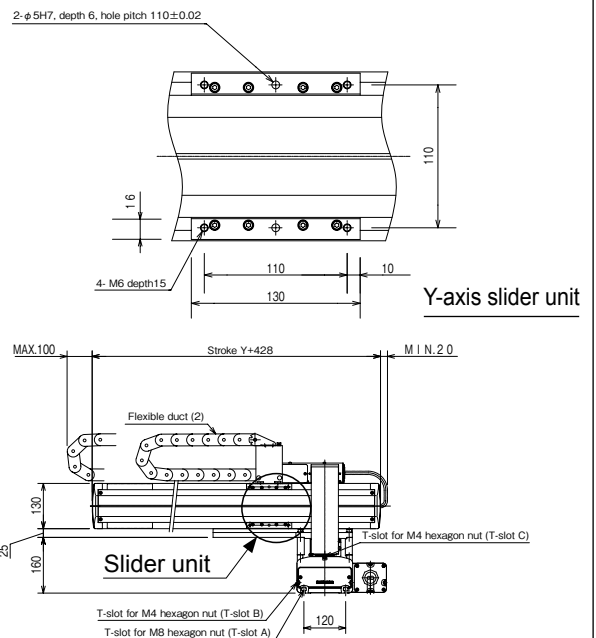
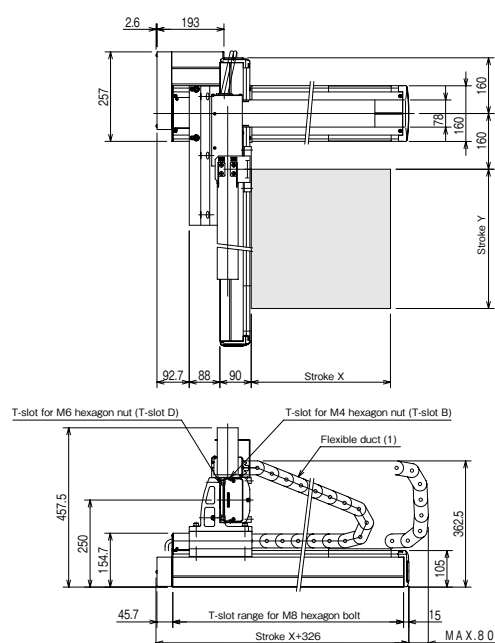



# Orthogonal Axes Specifications

[Set designation]

**BA2 – A5 – A2B R G – 40 40 00 – OT 1 3**

Combined operation	Axis 1 stroke	Axis 2 stroke	Controller	Cable length	
R: Right-handed	20 : 200mm	10 : 100mm	0: None	3 : 3m	9 : 9m
L: Left-handed	90 : 900mm A0 : 1000mm F0 : 1500mm	90 : 900mm A0 : 1000mm	1: CA20-M10 2: CA10-M00B 3: CA10-M01B	5 : 5m	B : 11m D : 13m

## Ball screw type

X-axis: Ball screw driven  
Side mounted motor

Y-axis: Ball screw driven  
Motor straight

Note 1: When the stroke is as given below, the maximum speed differs.

[Specifications]

	X-axis	Y-axis
Type of axis	BB50F-U □ -M20N- □ 0	BB30F-ST-M20N- □ 0
Stroke (in increments of 100 mm)	200 ~ 1500mm	100 ~ 1000mm
Maximum speed	1,200 mm/s (Note 1)	1,200 mm/s (Note 1)
Positioning repeatability (mm)	±0.01mm	
Lead of ball screw	20mm	20mm
Motor output	200W	200W
Resolution	0.01mm	

Acceleration/deceleration time when the maximum speed is set: 0.36 sec. or over

	Stroke (mm)	Maximum speed (mm/s)
X-axis	700 ~ 800	1100
	900 ~ 1000	1000
	1100 ~ 1200	700
	1300	500
	1400	400
Y-axis	1500	300
	700	1000
	800	800
	900 ~ 1000	600

Maximum Payload (kg)	Y-axis stroke									
	100mm	200mm	300mm	400mm	500mm	600mm	700mm	800mm	900mm	1000mm
	40.0 (31.0)	40.0 (30.0)	33.0 (29.0)	31.0 (28.0)	27.0	23.0	20.0	17.0	14.0	12.0

When the X-axis speed exceeds 1,000 m/s, the values in parentheses are used for the maximum Payload.

R: Right-handed

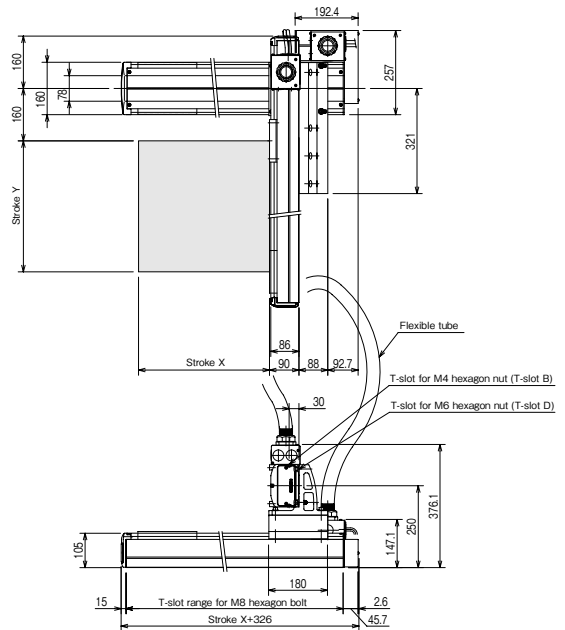
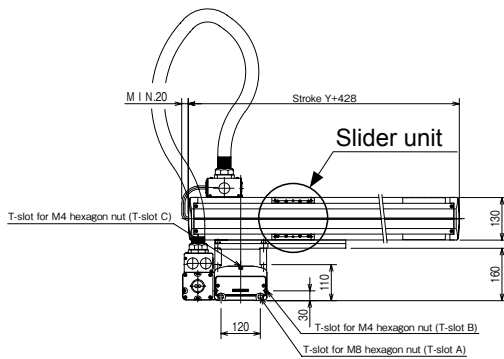
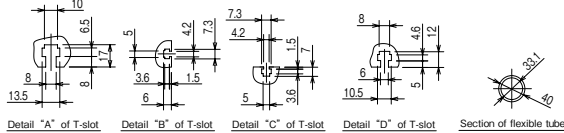

L: Left-handed

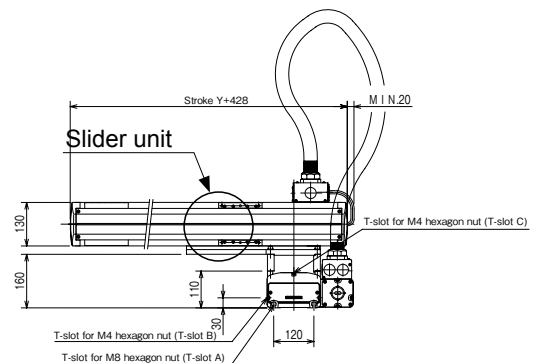
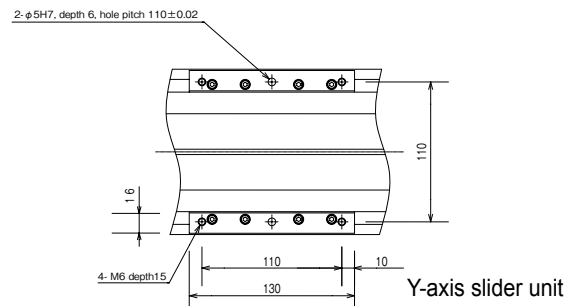
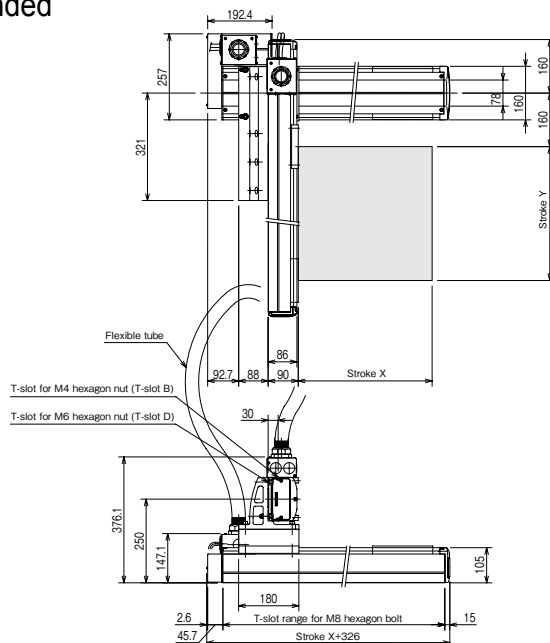

X-Y Flexible-tube Spec., Space-saving type

[Set designation]

**BA2 - L1 - A2A RC - 40 45 00 - OF 1 3**

Combined operation	Axis 1 stroke	Axis 2 stroke	Controller	Cable length	
R: Right-handed	10 : 100mm	15 : 150mm	0: None	3 : 3m	9 : 9m
L: Left-handed	90 : 900mm A0 : 1000mm H0 : 1700mm J0 : 1800mm	65 : 650mm	1: CA20-M10 2: CA10-M00B 3: CA10-M01B	5 : 5m	B : 11m D : 13m

**Timing belt type**

X-axis: Timing belt driven  
Side mounted motor

Y-axis: Timing belt driven  
Side mounted motor

[Specifications]

	X-axis	Y-axis
Type of axis	BB10E-BT-M21N-□ 0	BB10E-B□ -S21N-□ 5
Stroke (in increments of 100 mm)	100 ~ 1800mm	150 ~ 650mm
Maximum speed	1000mm/s	1000mm/s
Positioning repeatability (mm)	±0.05mm	
Lead	21mm	21mm
Motor output	100W	100W
Resolution	0.01mm	

Acceleration/deceleration time when the maximum speed is set: 0.4 sec. or over

Maximum Payload (kg)	Y-axis stroke					
	150mm	250mm	350mm	450mm	550mm	650mm
	8.0	8.0	6.0	5.0	3.0	1.0

**R: Right-handed**

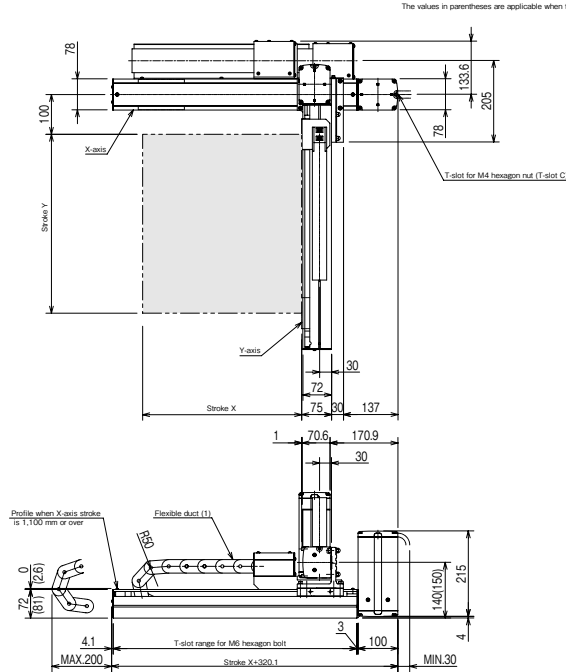
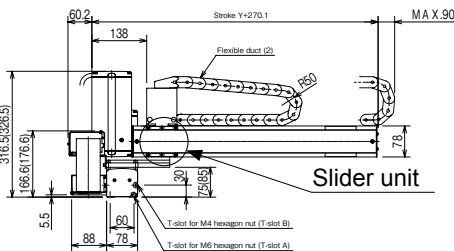
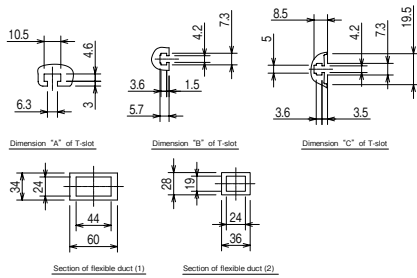

The values in parentheses are applicable when the X-axis stroke is 1,100 mm or over.

**L: Left-handed**

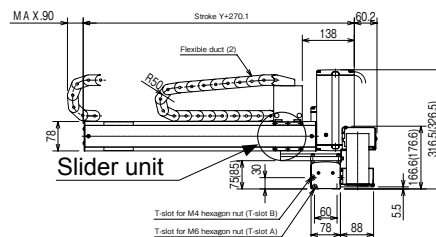
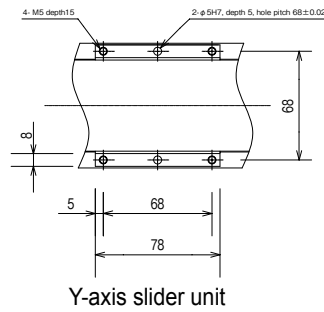
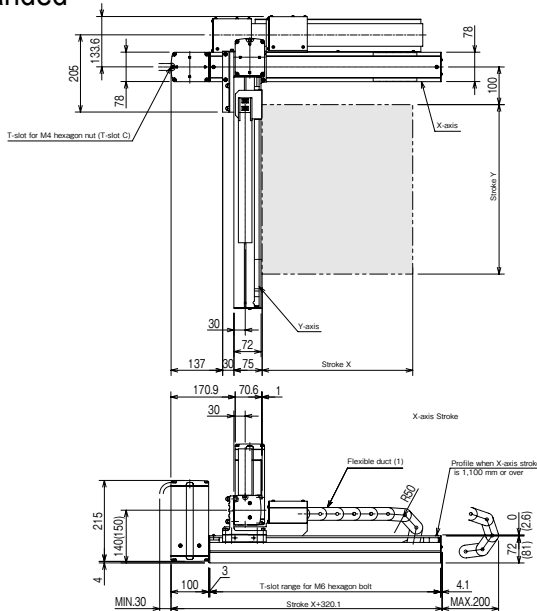

# Orthogonal Axes Specifications

[Set designation]

**BA2 - L1 - A2B RC - 40 45 00 - OF 1 3**

Timing belt type

X-axis: Timing belt driven  
Side mounted motor  
Y-axis: Timing belt driven  
Side mounted motor

Combined operation	Axis 1 stroke	Axis 2 stroke	Controller	Cable length	
R: Right-handed	10 : 100mm	15 : 150mm	0: None	3 : 3m	9 : 9m
L: Left-handed	90 : 900mm A0 : 1000mm	65 : 650mm	1: CA20-M10 2: CA10-M00B 3: CA10-M01B	5 : 5m	B : 11m D : 13m
	H0 : 1700mm J0 : 1800mm			7 : 7m	

[Specifications]

	X-axis	Y-axis
Type of axis	BB10F-BT-M21N- <input type="checkbox"/> 0	BB10E-B <input type="checkbox"/> -S21N- <input type="checkbox"/> 5
Stroke (in increments of 100 mm)	100 ~ 1800mm	150 ~ 650mm
Maximum speed	1000mm/s	1000mm/s
Positioning repeatability (mm)	±0.05mm	
Lead	21mm	21mm
Motor output	200W	100W
Resolution	0.01mm	

Acceleration/deceleration time when the maximum speed is set: 0.3 sec. or over

Maximum Payload (kg)	Y-axis stroke					
	150mm	250mm	350mm	450mm	550mm	650mm
	9.0	8.0	6.0	5.0	3.0	1.0

### R: Right-handed

The values in parentheses are applicable when the X-axis stroke is 1,100 mm or over.

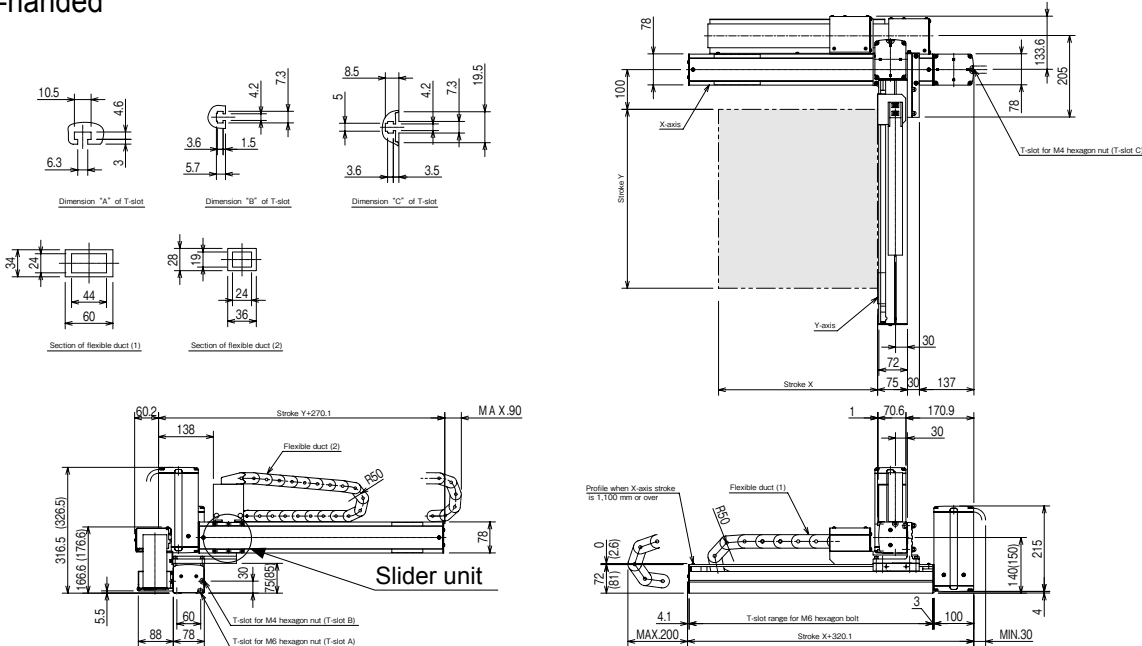

### L: Left-handed

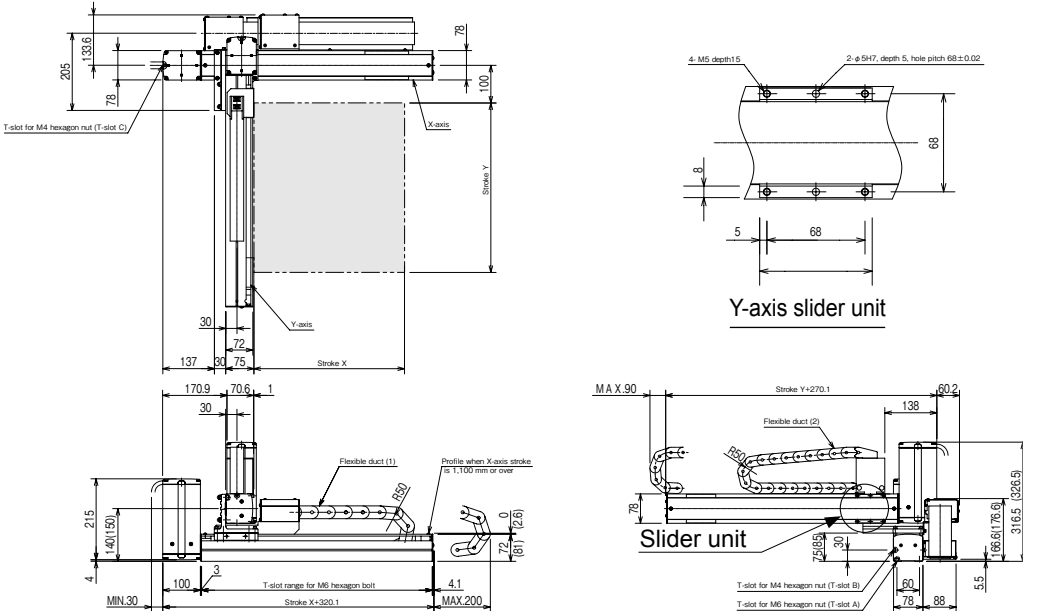

[Set designation]

**BA2 - L3 - A2A R C - 40 40 00 - OF 1 3**

**Timing belt type**

X-axis: Timing belt driven  
Side mounted motor

Y-axis: Timing belt driven  
Side mounted motor

Combined operation	Axis 1 stroke	Axis 2 stroke	Controller	Cable length
R: Right-handed	10 : 100mm ? : 1800mm	10 : 100mm ? : 800mm	0: None	3 : 3m 9 : 9m
L: Left-handed	90 : 900mm A0 : 1000mm ? : 2300mm H0 : 1700mm	80 : 800mm	1: CA20-M10 2: CA10-M00B 3: CA10-M01B	5 : 5m B : 11m 7 : 7m D : 13m

[Specifications]

	X-axis	Y-axis
Type of axis	BB30E-BT-M21N-□ 0	BB10E-B□ -M21N-□ 0
Stroke (in increments of 100 mm)	100 ~ 2500mm	100 ~ 800mm
Maximum speed	1000mm/s	1000mm/s
Positioning repeatability (mm)	±0.05mm	
Lead	21mm	21mm
Motor output	100W	100W
Resolution	0.01mm	

Acceleration/deceleration time when the maximum speed is set: 0.3 sec. or over

Maximum Payload (kg)	Y-axis stroke							
	100mm	200mm	300mm	400mm	500mm	600mm	700mm	800mm
	8.0	7.0	6.0	6.0	5.0	5.0	1.0	1.0

R: Right-handed

The values in parentheses are applicable when the X-axis stroke is 1,900 mm or over.

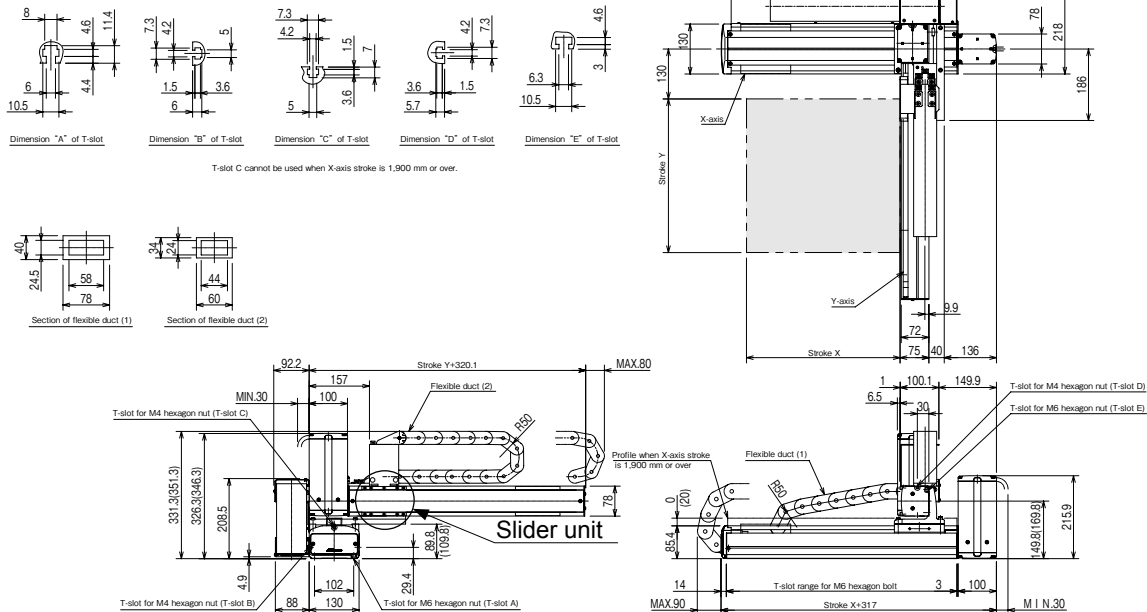

L: Left-handed

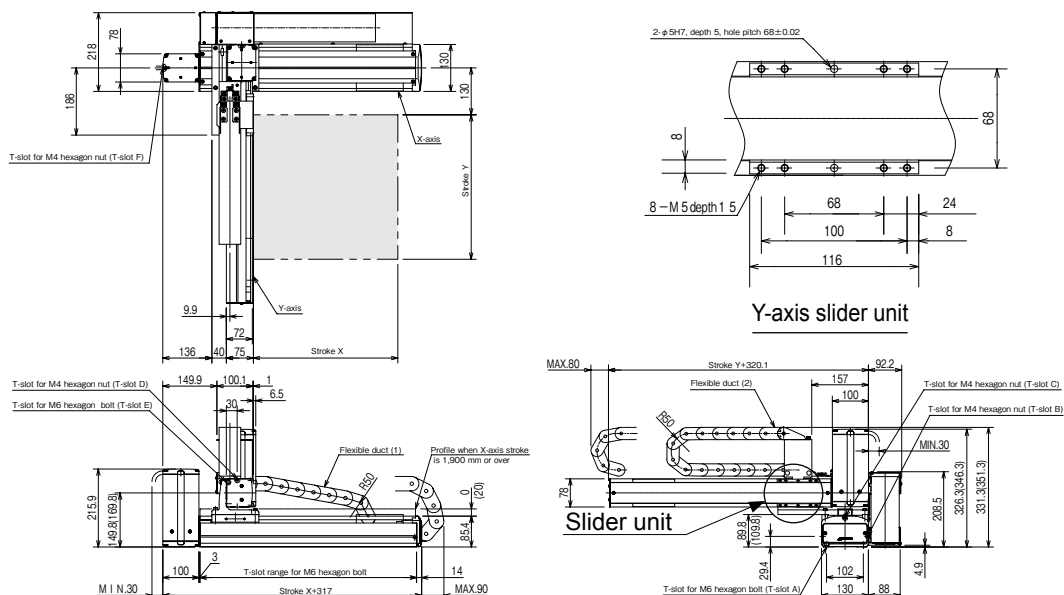

X-Y Flexible-duct Spec.

[Set designation]

**BA2 – L3 – A2B R C – 40 40 00 – OF 1 3**

Timing belt type

X-axis: Timing belt driven  
Side mounted motor  
Y-axis: Timing belt driven  
Side mounted motor

Combined operation	Axis 1 stroke	Axis 2 stroke	Controller	Cable length
R: Right-handed	10 : 100mm ? : 1800mm	10 : 100mm	0: None	3 : 3m 9 : 9m
L: Left-handed	90 : 900mm A0 : 1000mm ? : 2300mm HO : 1700mm	80 : 800mm	1: CA20-M10 2: CA10-M00B 3: CA10-M01B	5 : 5m 7 : 7m B : 11m D : 13m

[Specifications]

	X-axis	Y-axis
Type of axis	BB30F-BT-M21N- <input type="checkbox"/> 0	BB10E-B <input type="checkbox"/> -M21N- <input type="checkbox"/> 0
Stroke (in increments of 100 mm)	100 ~ 2500mm	100 ~ 800mm
Maximum speed	1000mm/s	1000mm/s
Positioning repeatability (mm)	±0.05mm	
Lead	21mm	21mm
Motor output	200W	100W
Resolution	0.01mm	

Acceleration/deceleration time when the maximum speed is set: 0.3 sec. or over

Maximum Payload (kg)	Y-axis stroke							
	100mm	200mm	300mm	400mm	500mm	600mm	700mm	800mm
	15.0	15.0	14.0	11.0	8.0	6.0	4.0	2.0

R: Right-handed

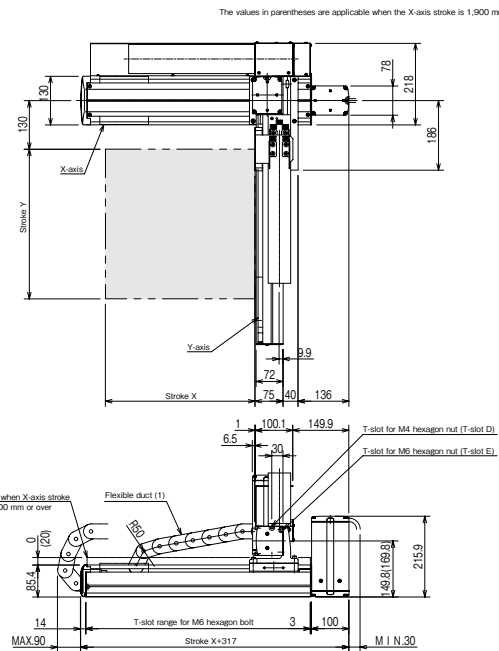
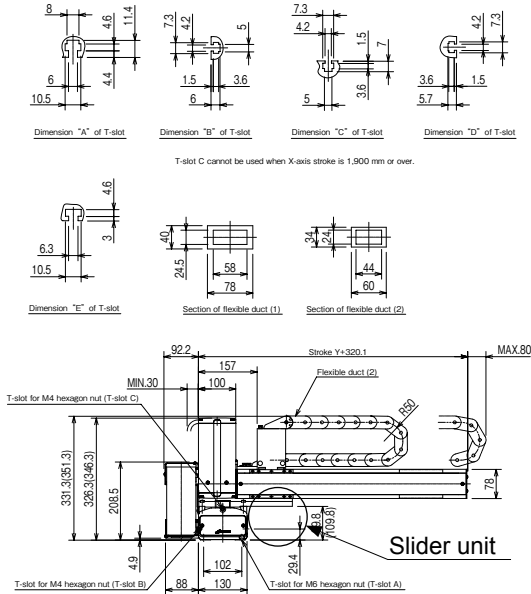

L: Left-handed

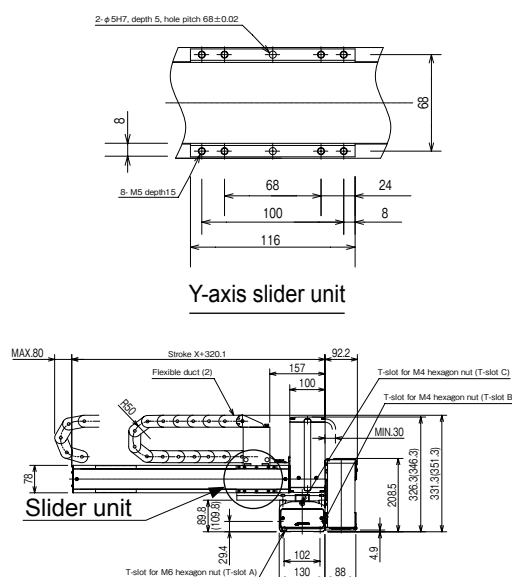
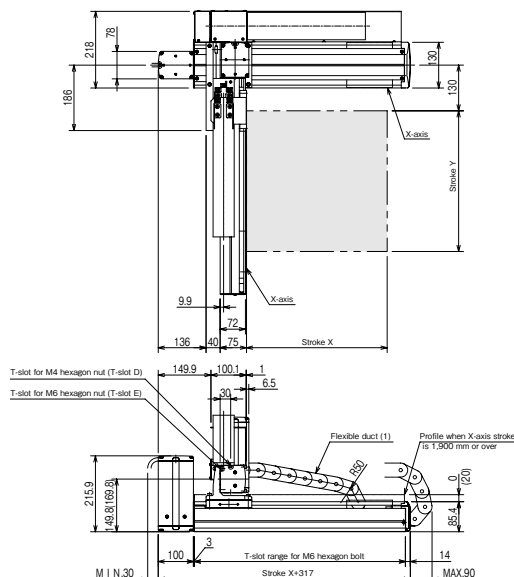

X-Y Flexible-duct Spec.

[Set designation]

BA2 - L3 - A2C R C - 40 40 00 - OF 1 3

Timing belt type

X-axis: Timing belt driven  
Side mounted motor

Y-axis: Timing belt driven  
Side mounted motor

Combined operation	Axis 1 stroke		Axis 2 stroke	Controller	Cable length	
R: Right-handed	10 : 100mm	J0 : 1800mm	10 : 100mm	0: None	3 : 3m	9 : 9m
L: Left-handed	90 : 900mm	N0 : 2200mm	80 : 800mm	1: CA20-M10	5 : 5m	B : 11m
	A0 : 1000mm	P0 : 2300mm		2: CA10-M00B	7 : 7m	D : 13m
	H0 : 1700mm	R0 : 2500mm		3: CA10-M01B		

[Specifications]

	X-axis	Y-axis
Type of axis	BB30F-BT-M21N-□0	BB10F-B□-M21N-□0
Stroke (in increments of 100 mm)	100 ~ 2500mm	100 ~ 800mm
Maximum speed	1000mm/s	1000mm/s
Positioning repeatability (mm)	±0.05mm	
Lead	21mm	21mm
Motor output	200W	200W
Resolution	0.01mm	

Acceleration/deceleration time when the maximum speed is set: 0.3 sec. or over

Maximum Payload (kg)	Y-axis stroke							
	100mm	200mm	300mm	400mm	500mm	600mm	700mm	800mm
	20.0	18.0	14.0	11.0	8.0	6.0	4.0	2.0

R: Right-handed

The values in parentheses are applicable when the X-axis stroke is 1,900 mm or over.

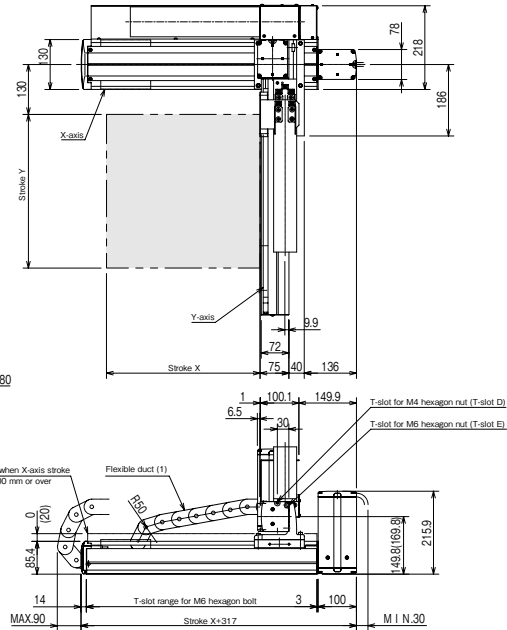
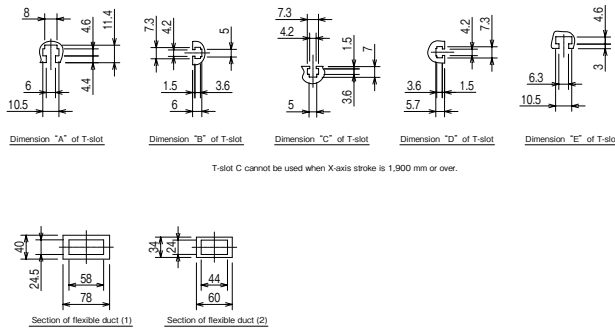

L: Left-handed

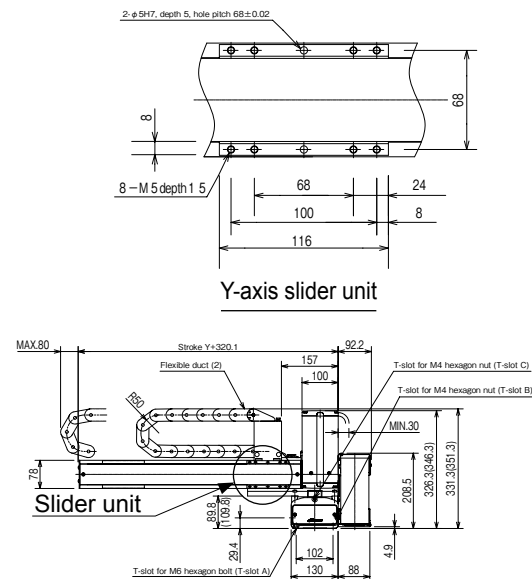
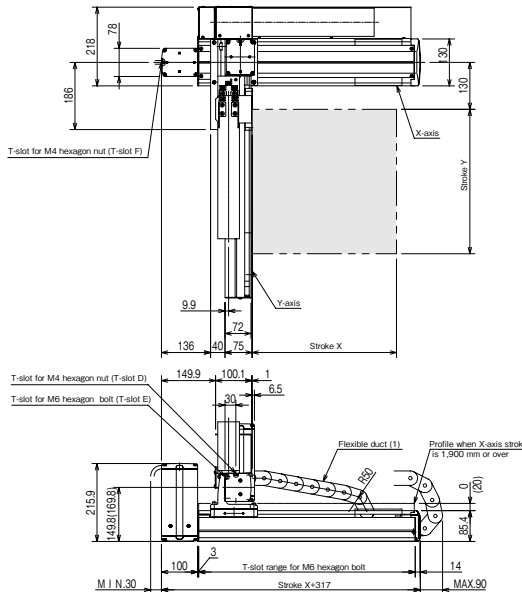

X-Y Flexible-duct Spec.

[Set designation]

## BA2 – L5 – A2A R C – 40 40 00 – OF 1 3

Timing belt type

X-axis: Timing belt driven  
Side mounted motor

Y-axis: Timing belt driven  
Side mounted motor

Combined operation	Axis 1 stroke	Axis 2 stroke	Controller	Cable length	
R: Right-handed	20 : 200mm J0 : 1800mm	10 : 100mm	0: None	3 : 3m	9 : 9m
L: Left-handed	90 : 900mm N0 : 2200mm A0 : 1000mm P0 : 2300mm H0 : 1700mm R0 : 2500mm	90 : 900mm A0 : 1000mm	1: CA20-M10 2: CA10-M00B 3: CA10-M01B	5 : 5m	B : 11m D : 13m

[Specifications]

	X-axis	Y-axis
Type of axis	BB50F-BT-M21N- □ 0	BB30E-B □ -M21N- □ 0
Stroke (in increments of 100 mm)	200 ~ 2500mm	100 ~ 1000mm
Maximum speed	1000mm/s	1000mm/s
Positioning repeatability (mm)	±0.05mm	
Lead	21mm	21mm
Motor output	200W	100W
Resolution	0.01mm	

Acceleration/deceleration time when the maximum speed is set: 0.3 sec. or over

Maximum Payload (kg)	Y-axis stroke									
	100mm	200mm	300mm	400mm	500mm	600mm	700mm	800mm	900mm	1000mm
	15.0	15.0	15.0	15.0	15.0	15.0	15.0	13.0	12.0	11.0

### R: Right-handed

The values in parentheses are applicable when the X-axis stroke is 1,900 mm or over.

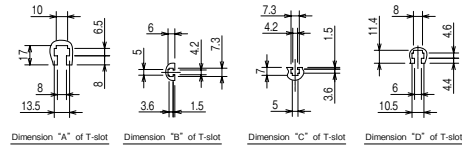

T-slot C cannot be used when X-axis stroke is 1,900 mm or over.

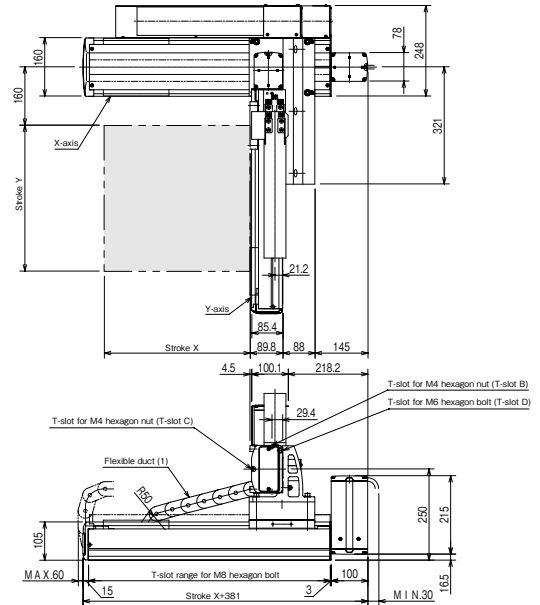
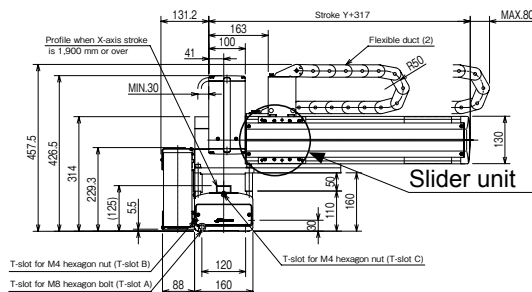
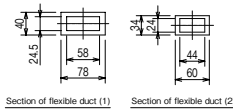

### L: Left-handed

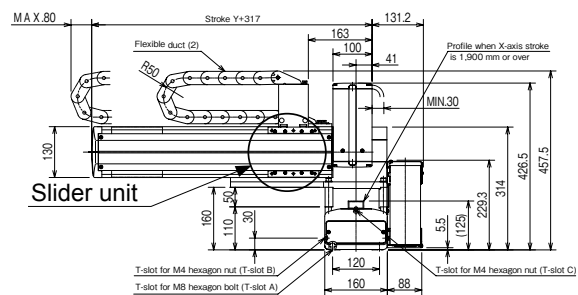
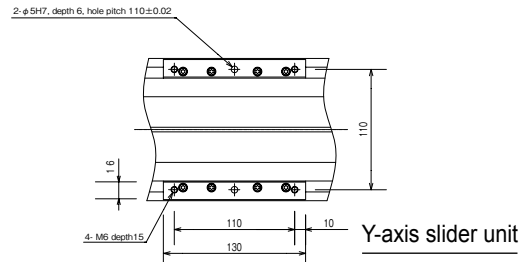
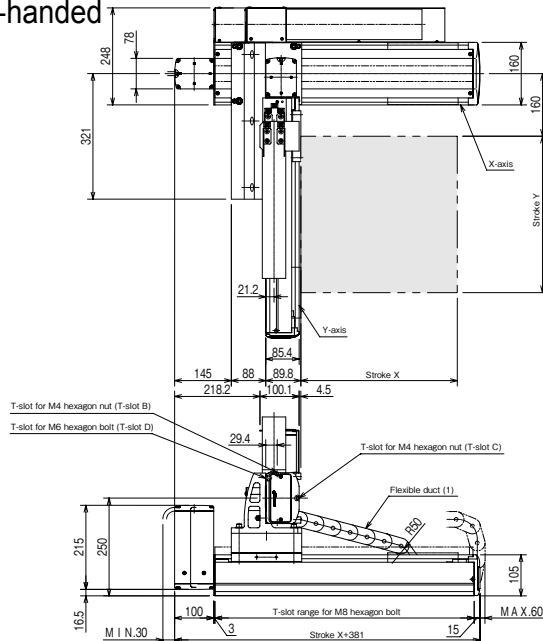

[Set designation]

**BA2 - L5 - A2B R C - 40 40 00 - OF 1 3**

**Timing belt type**

X-axis: Timing belt driven  
Side mounted motor  
Y-axis: Timing belt driven  
Side mounted motor

Combined operation	Axis 1 stroke	Axis 2 stroke	Controller	Cable length
R: Right-handed	20 : 200mm J0 : 1800mm	10 : 100mm	0: None	3 : 3m 9 : 9m
L: Left-handed	90 : 900mm A0 : 1000mm N0 : 2200mm P0 : 2300mm H0 : 1700mm R0 : 2500mm	90 : 900mm A0 : 1000mm	1: CA20-M10 2: CA10-M00B 3: CA10-M01B	5 : 5m 7 : 7m B : 11m D : 13m

[Specifications]

	X-axis	Y-axis
Type of axis	BB50F-BT-M21N-□ 0	BB30F-B□ -M21N-□ 0
Stroke (in increments of 100 mm)	200 ~ 2500mm	100 ~ 1000mm
Maximum speed	1000mm/s	1000mm/s
Positioning repeatability (mm)	±0.05mm	
Lead	21mm	21mm
Motor output	200W	200W
Resolution	0.01mm	

Acceleration/deceleration time when the maximum speed is set: 0.3 sec. or over

Maximum Payload (kg)	Y-axis stroke									
	100mm	200mm	300mm	400mm	500mm	600mm	700mm	800mm	900mm	1000mm
	20.0	19.0	18.0	17.0	16.0	15.0	14.0	13.0	12.0	10.0

### R: Right-handed

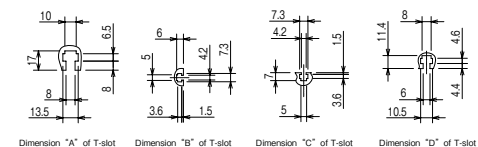

T-slot C cannot be used when X-axis stroke is 1,900 mm or over.

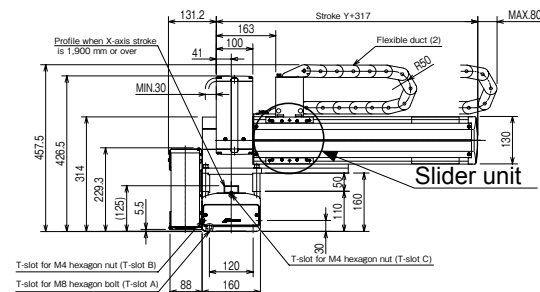
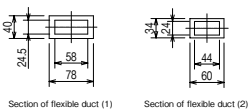

The values in parentheses are applicable when the X-axis stroke is 1,900 mm or over.

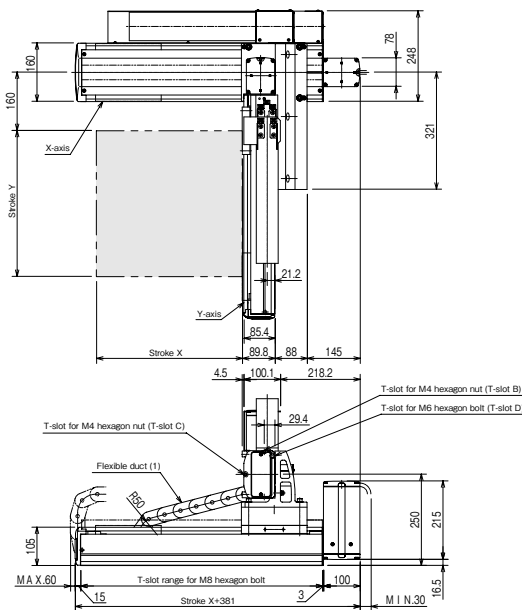

### L: Left-handed

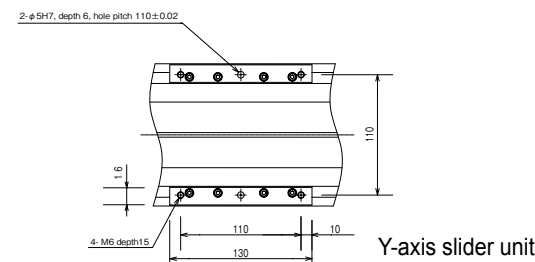
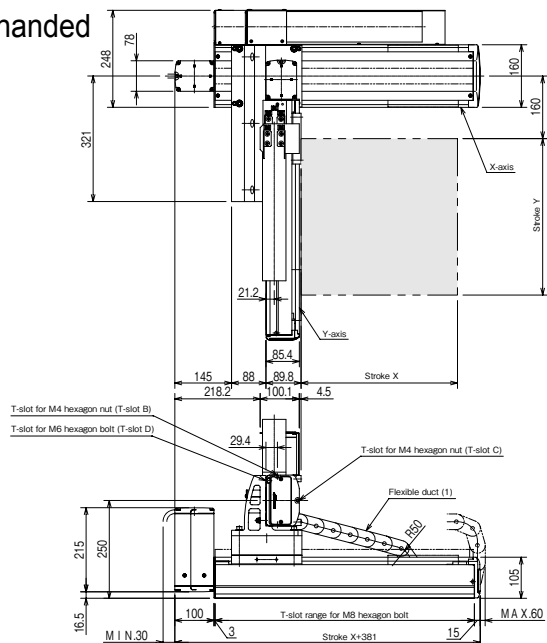



[Set designation]

**BA2 - A1 - B2A S A - 40 45 00 - OF 1 3**

Combined operation	Axis 1 stroke	Axis 2 stroke	Controller	Cable length	
S: Right-handed M: Left-handed	10 : 100mm 90 : 950mm A0 : 1000mm	15 : 150mm 45 : 450mm	0: None 1: CA20-M10 2: CA10-M00B 3: CA10-M01B	3 : 3m 5 : 5m 7 : 7m	9 : 9m B : 11m D : 13m

**Ball screw type**

X-axis: Ball screw driven  
Motor straight  
Z-axis: Ball screw driven  
Motor straight

[Specifications]

	X-axis	Z-axis
Type of axis	BB10E-ST-M20N-□ 0	BB10E-ST-S10B-□ 5
Stroke (in increments of 100 mm)	100 ~ 1000mm	150 ~ 450mm
Maximum speed	1,200 mm/s (Note 1)	600mm/s
Positioning repeatability	±0.01mm	
Ball screw lead	20mm	10mm
Motor output	100W	100 W, with brake
Resolution	0.01mm	

Acceleration/deceleration time when the maximum speed is set: 0.36 sec. or over

Note 1: When the stroke is as given below, the maximum speed differs.

	Stroke (mm)	Maximum speed (mm/s)
X-axis	700	1000
	800	800
	900 ~ 1000	600

Maximum Payload (kg) (Note 2)	Z-axis stroke			
	150mm	250mm	350mm	450mm
	8.0	6.0	4.0	2.0

Note 2: Payload when a regeneration discharge unit (ABSU-2000) is used

**S: Right-handed**

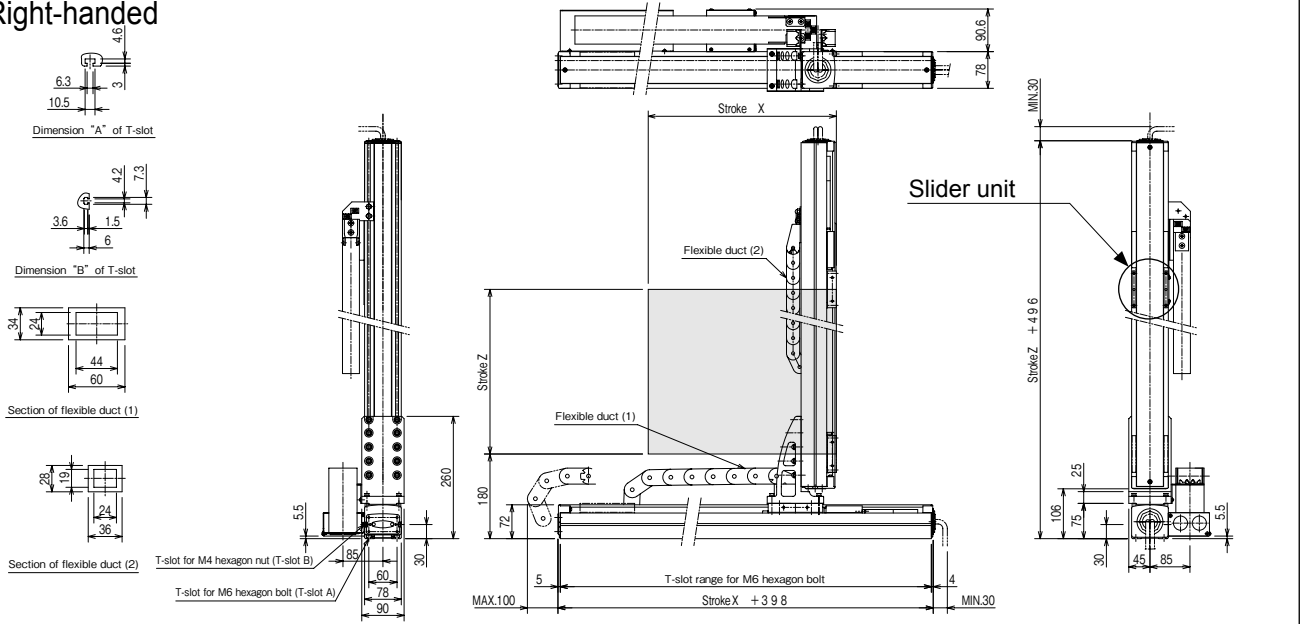

**M: Left-handed**

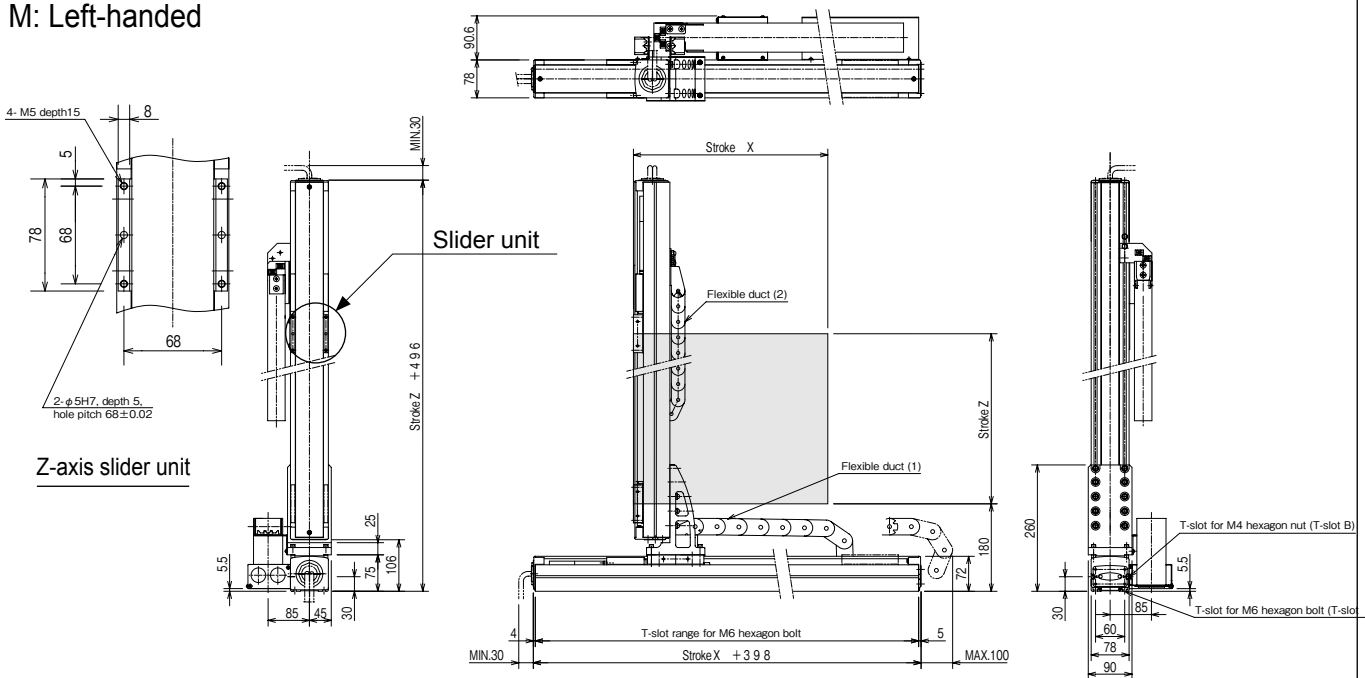

X-Z Flexible-duct Spec.

[Set designation]

**BA2 – A1 – B2A R A – 40 45 00 – OT 1 3**

**Ball screw type**

X-axis: Ball screw driven  
Motor straight  
Z-axis: Ball screw driven  
Motor straight

Combined operation R: Right-handed L: Left-handed	Axis 1 stroke 10 : 100mm 90 : 900mm A0 : 1000mm	Axis 2 stroke 15 : 150mm 45 : 450mm	Controller 0: None 1: CA20-M10 2: CA10-M00B 3: CA10-M01B	Cable length 3 : 3m 9 : 9m 5 : 5m B : 11m 7 : 7m D : 13m
---	--	---	--	---

[Specifications]

	X-axis	Z-axis
Type of axis	BB10E-ST-M20N-□ 0	BB10E-ST-S10B-□ 5
Stroke (in increments of 100 mm)	100 ~ 1000mm	150 ~ 450mm
Maximum speed	1,200 mm/s (Note 1)	600mm/s
Positioning repeatability	±0.01mm	
Ball screw lead	20mm	10mm
Motor output	100W	100 W, with brake
Resolution	0.01mm	

Note 1: When the stroke is as given below, the maximum speed differs.

	Stroke (mm)	Maximum speed (mm/s)
X-axis	700	1000
	800	800
	900 ~ 1000	600

Acceleration/deceleration time when the maximum speed is set: 0.36 sec. or over

Maximum Payload (kg) (Note 2)	Z-axis stroke			
	150mm	250mm	350mm	450mm
	8.0	6.0	4.0	2.0

Note 2: Payload when a regeneration discharge unit (ABSU-2000) is used

R: Right-handed

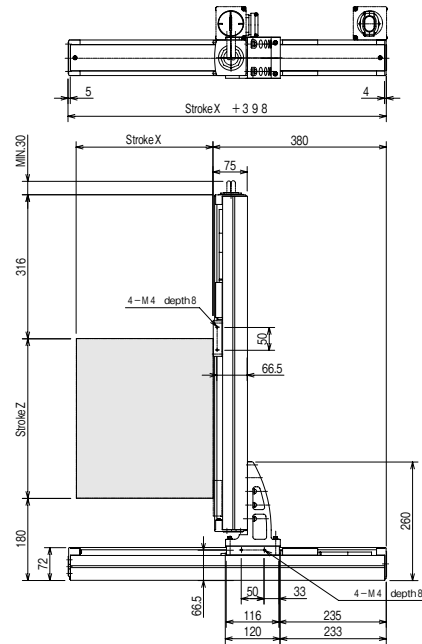
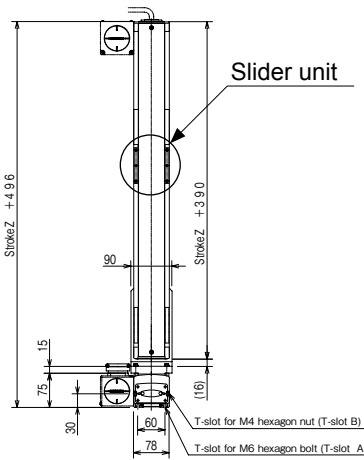
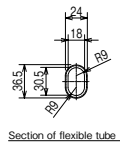
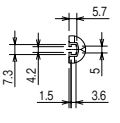
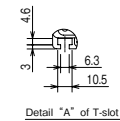

L: Left-handed

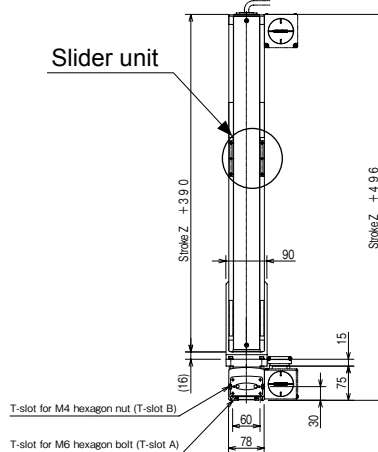
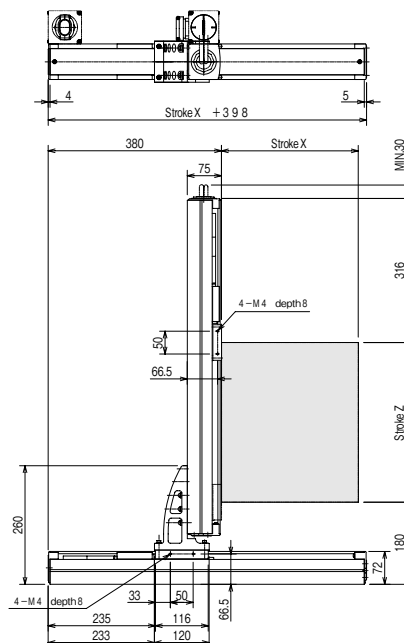
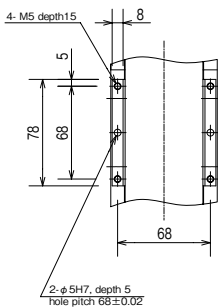

[Set designation]

**BA2 - A3 - B2A S A - 45 40 00 - OF 1 3**

Combined operation S: Right-handed M: Left-handed	Axis 1 stroke 15 : 150mm 95 : 950mm A5 : 1050mm	Axis 2 stroke 10 : 100mm 40 : 400mm	Controller 0: None 1: CA20-M10 2: CA10-M00B 3: CA10-M01B	Cable length 3 : 3m 9 : 9m 5 : 5m B : 11m 7 : 7m D : 13m
---	--	---	--	---

Ball screw type

X-axis: Ball screw driven  
Motor straight  
Z-axis: Ball screw driven  
Motor straight

[Specifications]

	X-axis	Z-axis
Type of axis	BB30E-ST-M20N-□ 0	BB10E-ST-M10B-□ 0
Stroke (in increments of 100 mm)	150 ~ 1050mm	100 ~ 700mm
Maximum speed	1,200 mm/s (Note 1)	600mm/s
Positioning repeatability	±0.01mm	
Ball screw lead	20mm	10mm
Motor output	100W	100 W, with brake
Resolution	0.01mm	

Note 1: When the stroke is as given below, the maximum speed differs.

	Stroke (mm)	Maximum speed (mm/s)
X-axis	750	1000
	850	800
	950 ~ 1050	600
Z-axis	700	500

Acceleration/deceleration time when the maximum speed is set: 0.6 sec. or over

Maximum Payload (kg) (Note 2)	Z-axis stroke						
	100mm	200mm	300mm	400mm	500mm	600mm	700mm
	9.0	8.0	8.0	8.0	6.0	4.0	2.0

Note 2: Payload when a regeneration discharge unit (ABSU-2000) is used

S: Right-handed

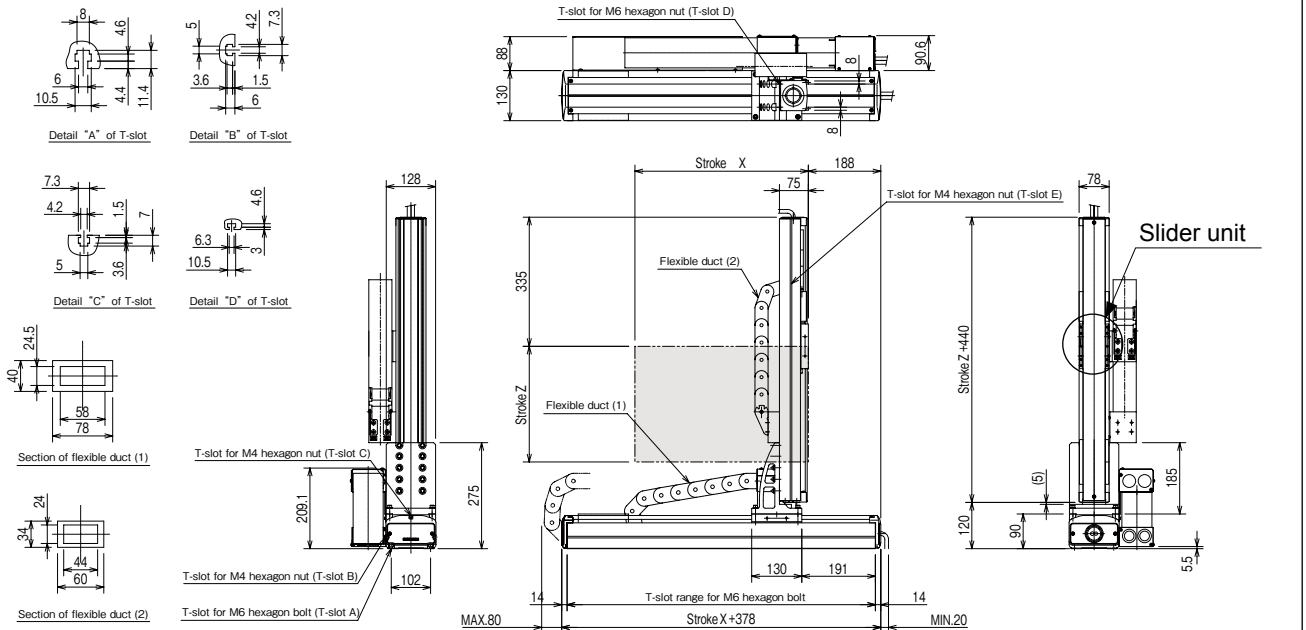

M: Left-handed

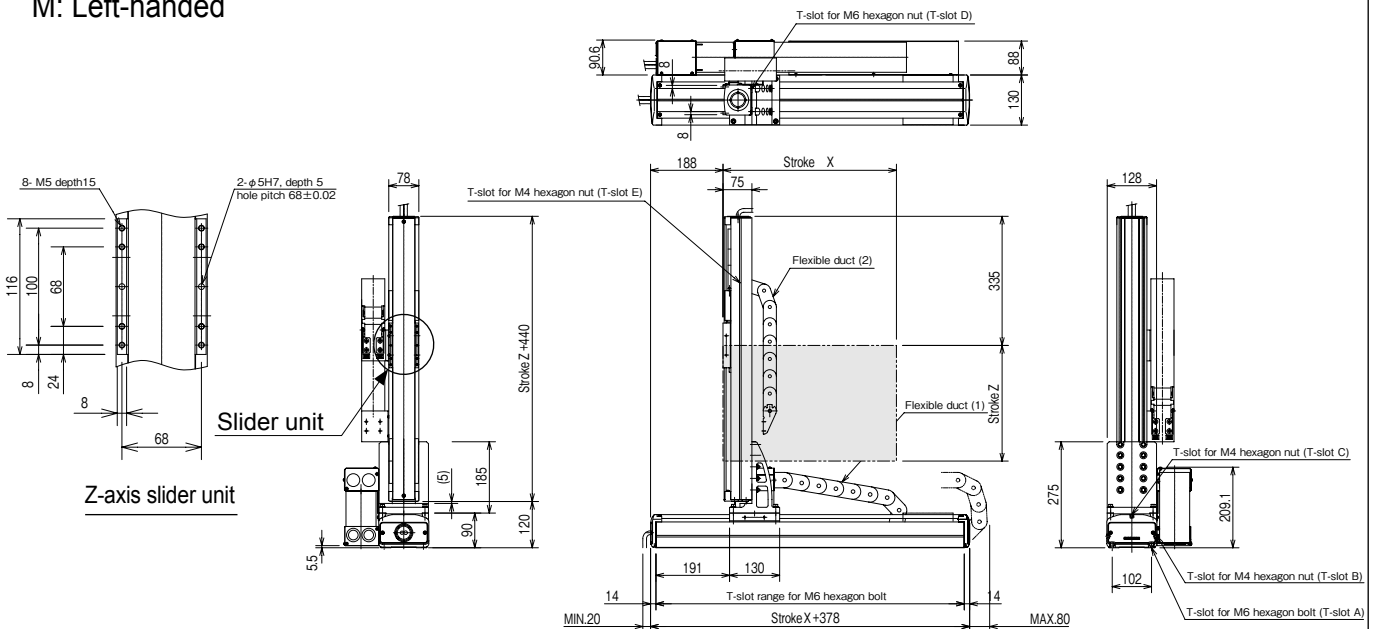

X-Z Flexible-duct Spec.

[Set designation]

**BA2 - A3 - B2A R A - 45 40 00 - OT 1 3**

Combined operation	Axis 1 stroke	Axis 2 stroke	Controller	Cable length
R: Right-handed L: Left-handed	15 : 150mm 95 : 950mm A5 : 1050mm	10 : 100mm 40 : 400mm	0: None 1: CA20-M10 2: CA10-M00B 3: CA10-M01B	3 : 3m 9 : 9m 5 : 5m B : 11m 7 : 7m D : 13m

**Ball screw type**

X-axis: Ball screw driven  
Motor straight  
Z-axis: Ball screw driven  
Motor straight

[Specifications]

	X-axis	Z-axis
Type of axis	BB30E-ST-M20N- □ 0	BB10E-ST-M10B- □ 0
Stroke (in increments of 100 mm)	150 ~ 1050mm	100 ~ 700mm
Maximum speed	1,200 mm/s (Note 1)	600 mm/s (Note 1)
Positioning repeatability	±0.01mm	
Ball screw lead	20mm	10mm
Motor output	100W	100 W, with brake
Resolution	0.01mm	

Note 1: When the stroke is as given below, the maximum speed differs.

	Stroke (mm)	Maximum speed (mm/s)
X-axis	750	1000
	850	800
	950 ~ 1050	600
Z-axis	700	500

Acceleration/deceleration time when the maximum speed is set: 0.6 sec. or over

Maximum Payload (kg) (Note 2)	Z-axis stroke						
	100mm	200mm	300mm	400mm	500mm	600mm	700mm
	9.0	8.0	8.0	8.0	6.0	4.0	2.0

Note 2: Payload when a regeneration discharge unit (ABSU-2000) is used.

**R: Right-handed**

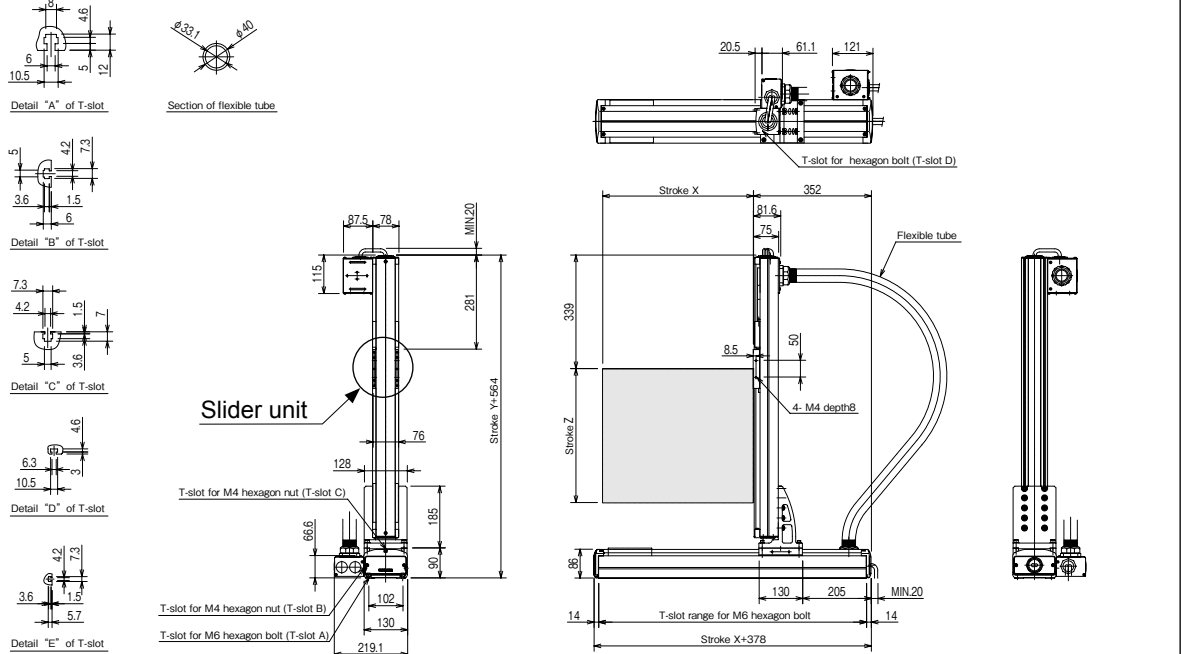

**L: Left-handed**

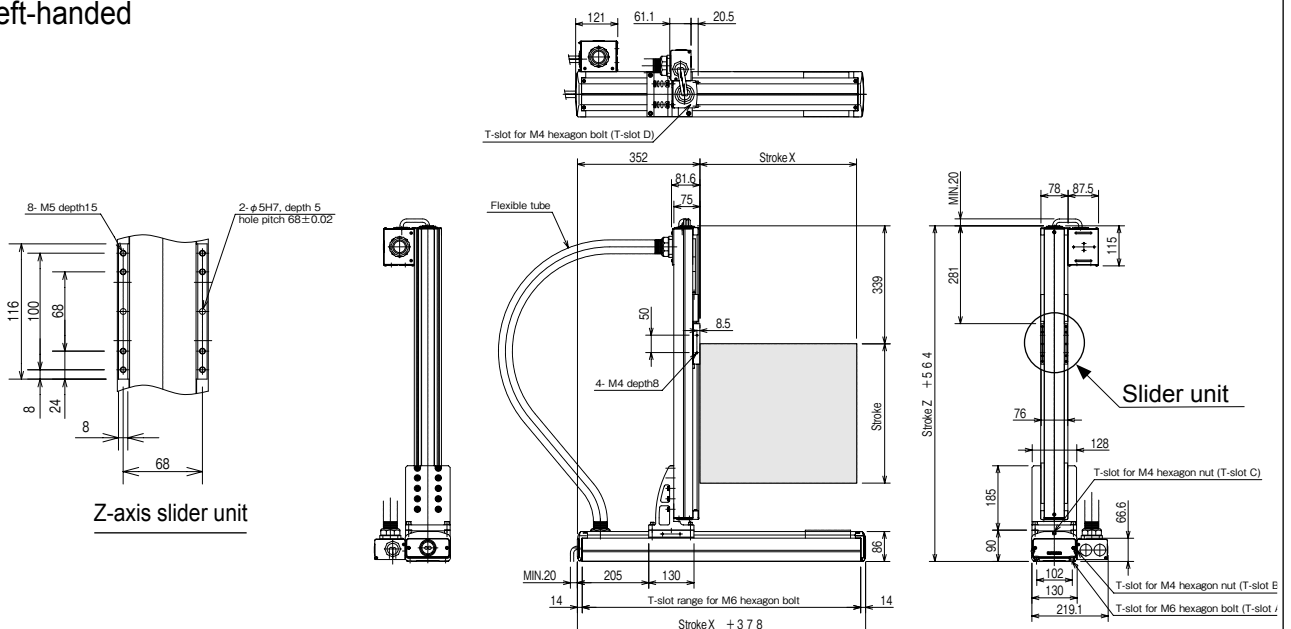

[Set designation]

**BA2 - A3 - B2B S A - 40 40 00 - OF 1 3**

**Ball screw type**

Combined operation	Axis 1 stroke	Axis 2 stroke	Controller	Cable length	
S: Right-handed	10 : 100mm	10 : 100mm	0: None	3 : 3m	9 : 9m
M: Left-handed	90 : 900mm	90 : 900mm	1: CA20-M10	5 : 5m	B : 11m
	A0 : 1000mm		2: CA10-M00B	7 : 7m	D : 13m
			3: CA10-M01B		

X-axis: Ball screw driven  
Motor straight  
Z-axis: Ball screw driven  
Motor straight

[Specifications]

	X-axis	Z-axis
Type of axis	BB30F-ST-M20N-□ 0	BB10E-ST-M10B-□ 0
Stroke (in increments of 100 mm)	100 ~ 1000mm	100 ~ 900mm
Maximum speed	1,200 mm/s (Note 1)	600 mm/s (Note 1)
Positioning repeatability	±0.01mm	
Ball screw lead	20mm	10mm
Motor output	200W	100 W, with brake
Resolution	0.01mm	

Note 1: When the stroke is as given below, the maximum speed differs.

	Stroke (mm)	Maximum speed (mm/s)
X-axis	750	1000
	850	800
	950 ~ 1050	600
Z-axis	700	500
	800	400
	900	300

Acceleration/deceleration time when the maximum speed is set: 0.36 sec. or over

Maximum Payload (kg) (Note 2)	Z-axis stroke								
	100mm	200mm	300mm	400mm	500mm	600mm	700mm	800mm	900mm
	12.0	12.0	12.0	12.0	12.0	10.0	4.0	2.0	2.0

Note 2: Payload when a regeneration discharge unit (ABSU-2000) is used

S: Right-handed

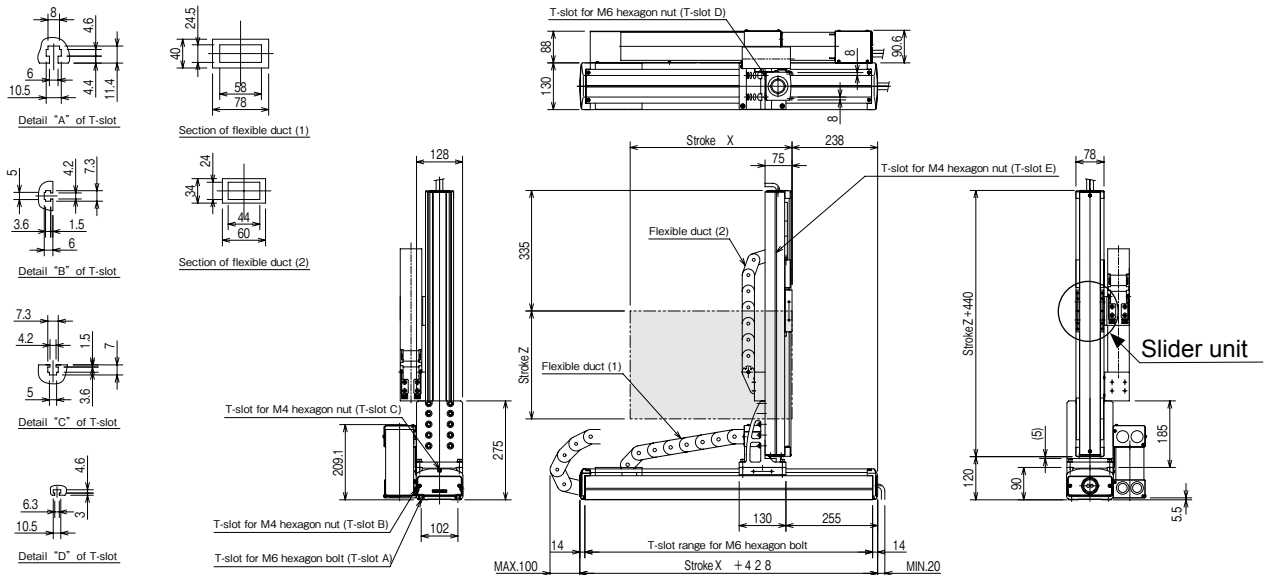

M: Left-handed

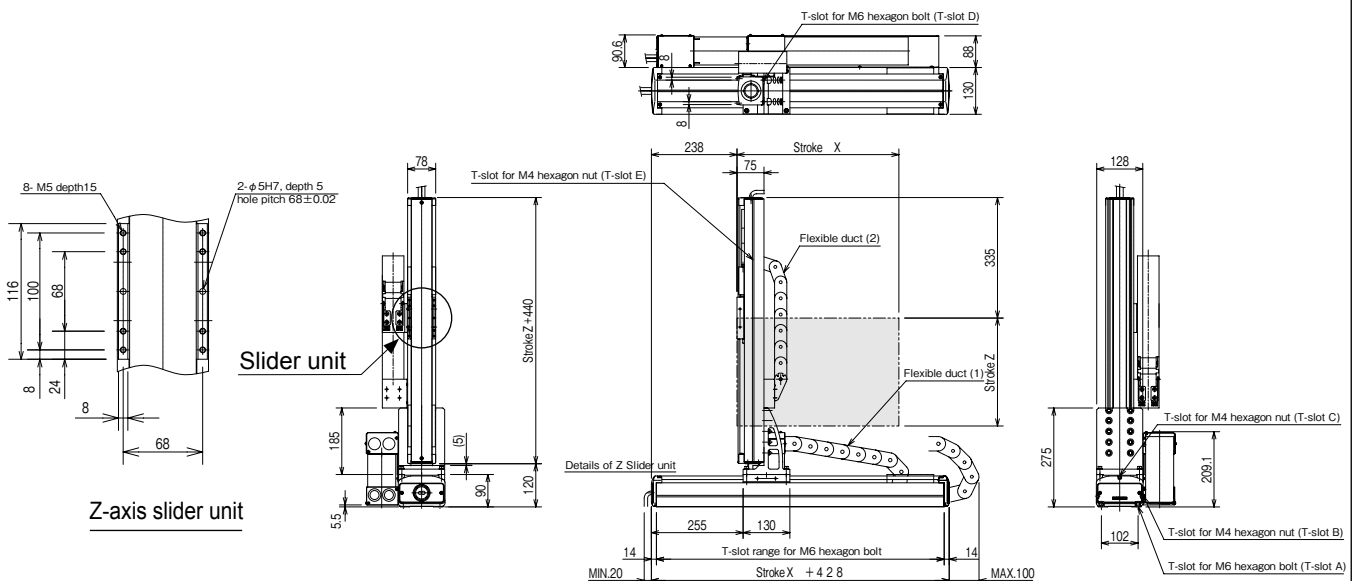

X-Z Flexible-duct Spec.

[Set designation]

**BA2 - A3 - B2B R A - 40 40 00 - OT 1 3**

Combined operation R: Right-handed L: Left-handed	Axis 1 stroke 15 : 150mm 90 : 900mm A0 : 1000mm	Axis 2 stroke 10 : 100mm 90 : 900mm	Controller 0: None 1: CA20-M10 2: CA10-M00B 3: CA10-M01B	Cable length 3 : 3m 9 : 9m 5 : 5m B : 11m 7 : 7m D : 13m
---	--	---	--	---

**Ball screw type**

X-axis: Ball screw driven  
Motor straight  
Z-axis: Ball screw driven  
Motor straight

[Specifications]

	X-axis	Z-axis
Type of axis	BB30F-ST-M20N- □ 0	BB10E-ST-M10B- □ 0
Stroke (in increments of 100 mm)	100 ~ 1000mm	100 ~ 900mm
Maximum speed	1,200 mm/s (Note 1)	600 mm/s (Note 1)
Positioning repeatability	±0.01mm	
Ball screw lead	20mm	10mm
Motor output	200W	100 W, with brake
Resolution	0.01mm	

Acceleration/deceleration time when the maximum speed is set: 0.36 sec. or over

Note 1: When the stroke is as given below, the maximum speed differs.

	Stroke (mm)	Maximum speed (mm/s)
X-axis	750	1000
	850	800
	950 ~ 1050	600
Z-axis	700	500
	800	400
	900	300

Maximum Payload (kg) (Note 2)	Z-axis stroke								
	100mm	200mm	300mm	400mm	500mm	600mm	700mm	800mm	900mm
	12.0	12.0	12.0	12.0	12.0	10.0	4.0	2.0	2.0

Note 2: Payload when a regeneration discharge unit (ABSU-2000) is used

**R: Right-handed**

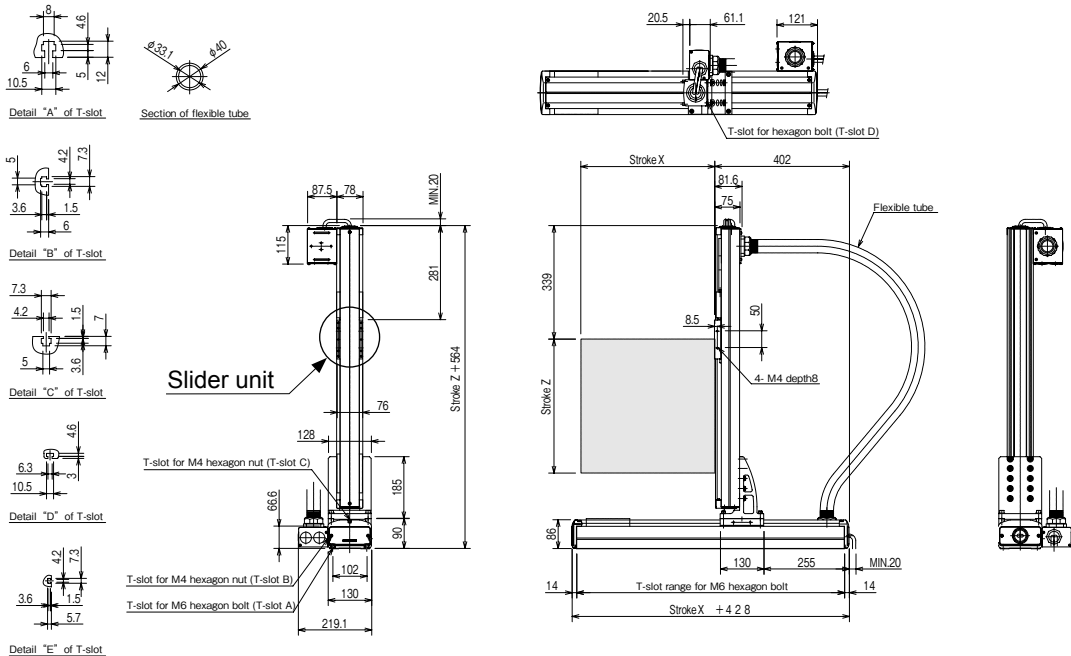

**L: Left-handed**

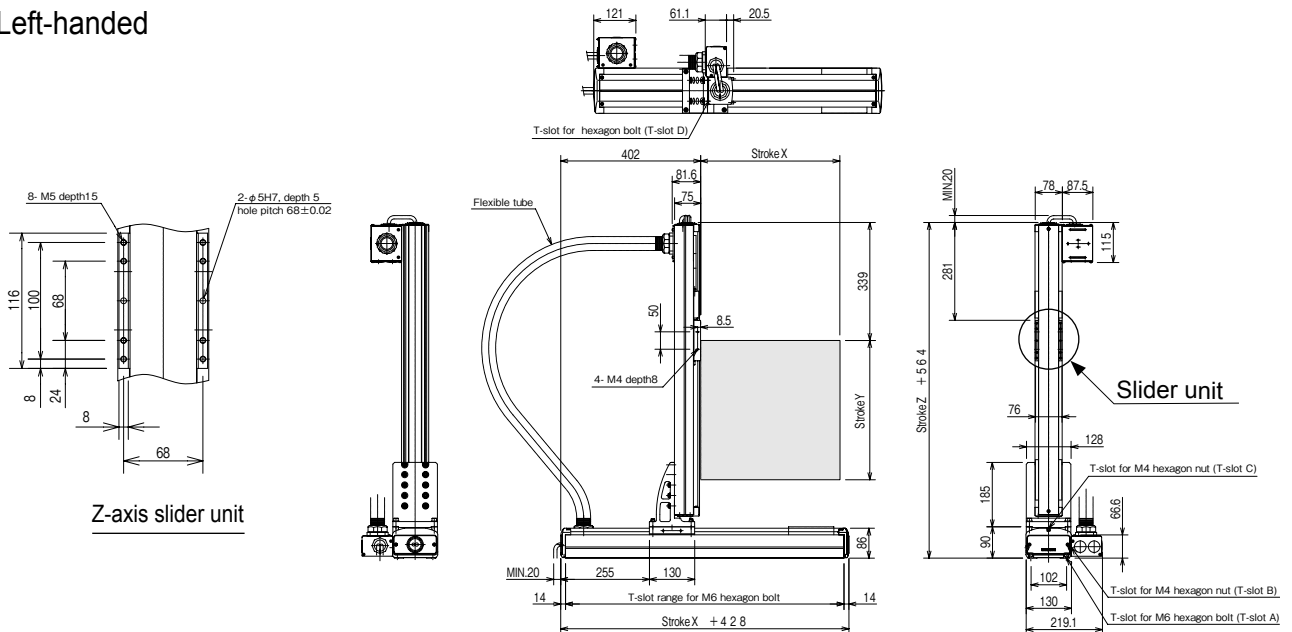

X-Z Flexible-tube Spec.

# Orthogonal Axes Specifications

[Set designation]

**BA2 - A5 - B2A S A - 40 45 00 - OF 1 3**

Combined operation	Axis 1 stroke	Axis 2 stroke	Controller	Cable length	
S: Right-handed M: Left-handed	10 : 100mm 90 : 900mm A0 : 1000mm F0 : 1500mm	15 : 150mm 95 : 950mm A5 : 1050mm	0: None 1: CA20-M10 2: CA10-M00B 3: CA10-M01B	3 : 3m 5 : 5m 7 : 7m	9 : 9m B : 11m D : 13m

## Ball screw type

X-axis: Ball screw driven  
Motor straight  
Z-axis: Ball screw driven  
Motor straight

Note 1: When the stroke is as given below, the maximum speed differs.

[Specifications]

	X-axis	Z-axis
Type of axis	BB50F-ST-M20N-□ 0	BB30E-ST-M10B-□ 0
Stroke (in increments of 100 mm)	200 ~ 1500mm	150 ~ 1050mm
Maximum speed	1,200 mm/s (Note 1)	600 mm/s (Note 1)
Positioning repeatability	±0.01mm	
Ball screw lead	20mm	10mm
Motor output	200W	100 W, with brake
Resolution	0.01mm	

Acceleration/deceleration time when the maximum speed is set: 0.36 sec. or over

	Stroke (mm)	Maximum speed (mm/s)
X-axis	700 ~ 800	1100
	900 ~ 1000	1000
	1100 ~ 1200	700
	1300	500
	1400	400
Z-axis	1500	300
	750	500
	850	400
	950 ~ 1050	300

Maximum Payload (kg) (Note 2)	Z-axis stroke									
	150mm	250mm	350mm	450mm	550mm	650mm	750mm	850mm	950mm	1050mm
	12.0	12.0	12.0	12.0	12.0	12.0	12.0	12.0	12.0	8.0

Note 2: Payload when a regeneration discharge unit (ABSU-2000) is used

## S: Right-handed

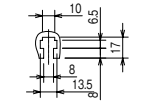

Dimension "A" of T-slot

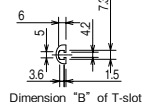

Dimension "B" of T-slot

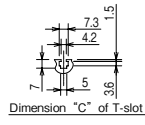

Dimension "C" of T-slot

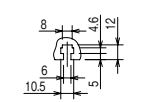

Dimension "D" of T-slot

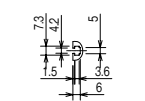

Dimension "E" of T-slot

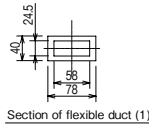

Section of flexible duct (1)

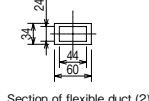

Section of flexible duct (2)

Slider unit

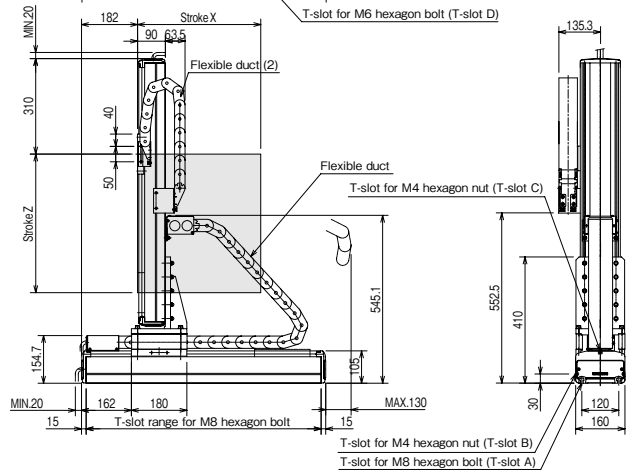
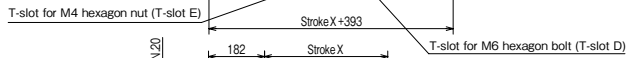
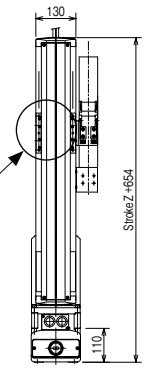

## M: Left-handed

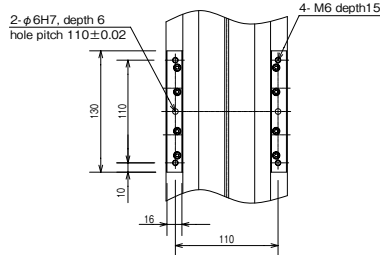

Z-axis slider unit

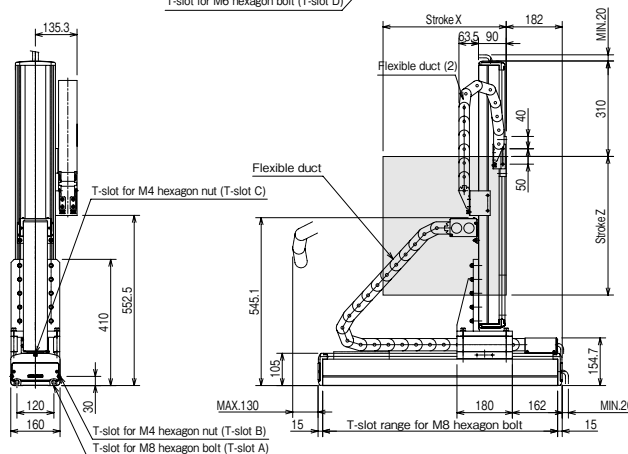
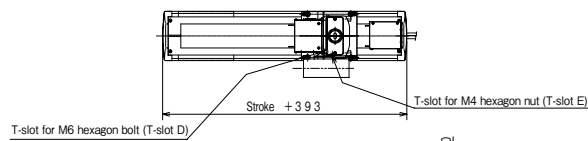

X-Z Flexible-duct Spec.

[Set designation]

**BA2 - A5 - B2A R A - 40 45 00 - OT 1 3**

Combined operation R: Right-handed L: Left-handed	Axis 1 stroke 10 : 100mm 90 : 900mm A0 : 1000mm F0 : 1500mm	Axis 2 stroke 15 : 150mm 95 : 950mm A5 : 1050mm	Controller 0: None 1: CA20-M10 2: CA10-M00B 3: CA10-M01B	Cable length 3 : 3m 5 : 5m 7 : 7m 9 : 9m B : 11m D : 13m
---	---	--	--	--

**Ball screw type**

- X-axis: Ball screw driven  
Motor straight
- Z-axis: Ball screw driven  
Motor straight

Note 1: When the stroke is as given below, the maximum speed differs.

[Specifications]

	X-axis	Z-axis
Type of axis	BB50F-ST-M20N- □ 0	BB30E-ST-M10B- □ 0
Stroke (in increments of 100 mm)	200 ~ 1500mm	150 ~ 1050mm
Maximum speed	1,200 mm/s (Note 1)	600 mm/s (Note 1)
Positioning repeatability	±0.01mm	
Ball screw lead	20mm	10mm
Motor output	200W	100 W, with brake
Resolution	0.01mm	

	Stroke (mm)	Maximum speed (mm/s)
X-axis	700 ~ 800	1100
	900 ~ 1000	1000
	1100 ~ 1200	700
	1300	500
	1400	400
Z-axis	1500	300
	750	500
	850	400
	950 ~ 1050	300

Acceleration/deceleration time when the maximum speed is set: 0.36 sec. or over

Maximum Payload (kg) (Note 2)	Z-axis stroke									
	150mm	250mm	350mm	450mm	550mm	650mm	750mm	850mm	950mm	1050mm
	12.0	12.0	12.0	12.0	12.0	12.0	12.0	12.0	12.0	8.0

Note 2: Payload when a regeneration discharge unit (ABSU-2000) is used

**R: Right-handed**

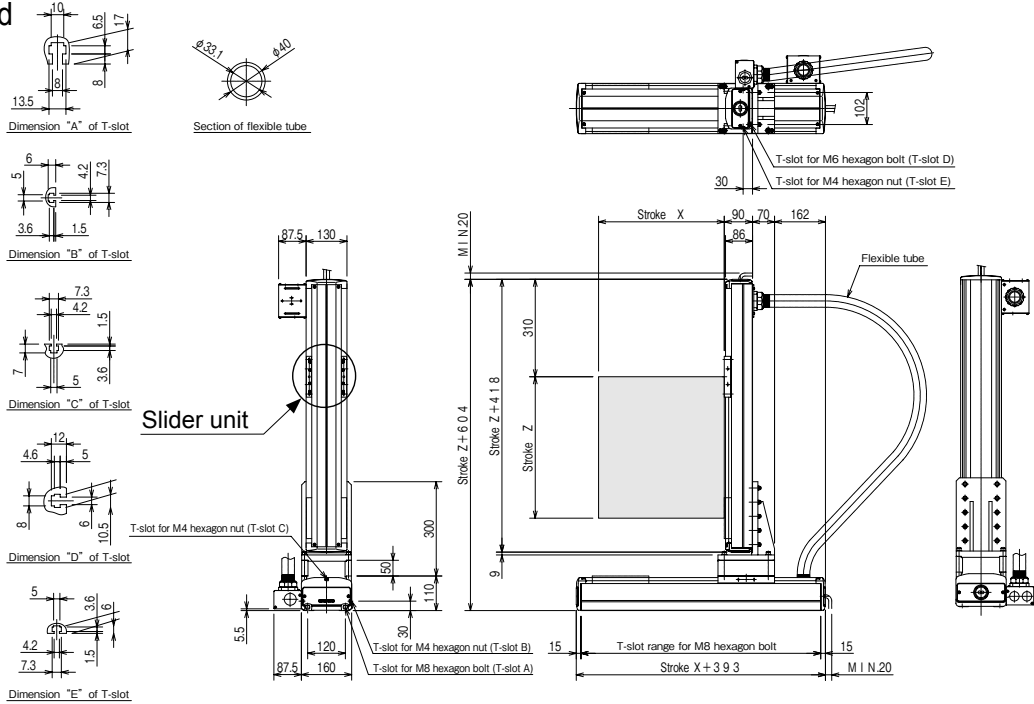

**L: Left-handed**

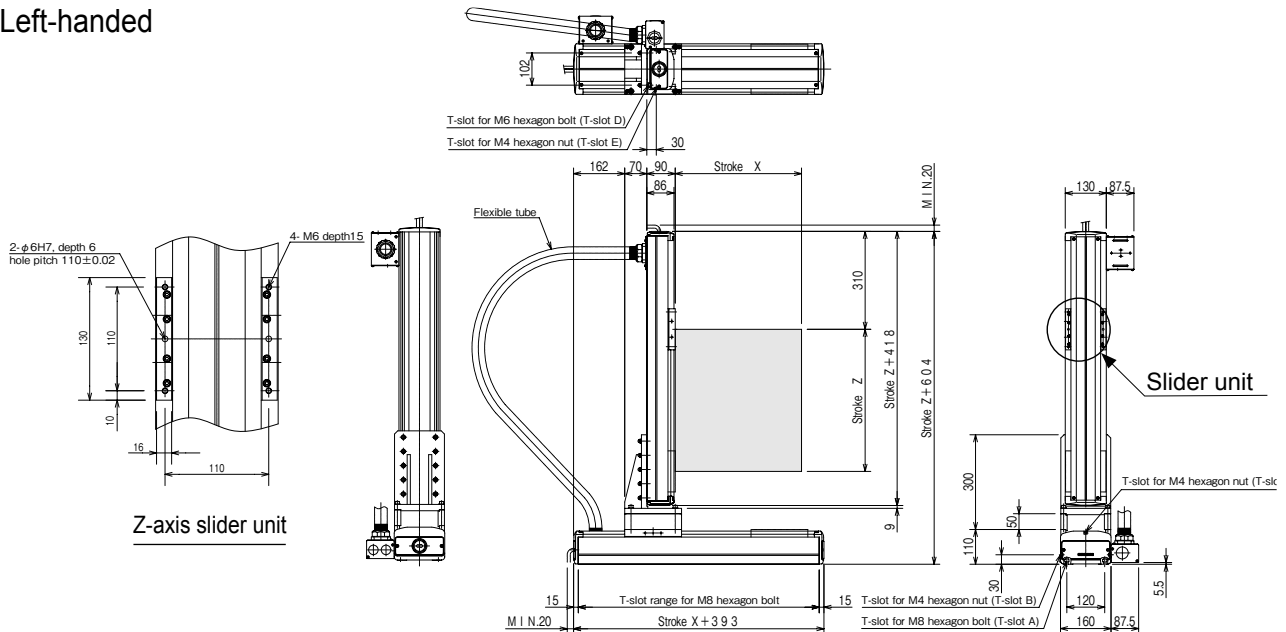



[Set designation]

**BA2 – A5 – B2B S A – 40 40 00 – OF 1 3**

Combined operation	Axis 1 stroke	Axis 2 stroke	Controller	Cable length	
S: Right-handed	10 : 100mm	10 : 100mm	0: None	3 : 3m	9 : 9m
M: Left-handed	90 : 900mm	90 : 900mm	1: CA20-M10	5 : 5m	B : 11m
	A0 : 1000mm	A0 : 1000mm	2: CA10-M00B	7 : 7m	D : 13m
	F0 : 1500mm		3: CA10-M01B		

**Ball screw type**

- X-axis: Ball screw driven  
Motor straight
- Z-axis: Ball screw driven  
Motor straight

Note 1: When the stroke is as given below, the maximum speed differs.

[Specifications]

	X-axis	Z-axis
Type of axis	BB50F-ST-M20N-□ 0	BB30F-ST-M10B-□ 0
Stroke (in increments of 100 mm)	200 ~ 1500mm	100 ~ 1000mm
Maximum speed	1,200 mm/s (Note 1)	600 mm/s (Note 1)
Positioning repeatability	±0.01mm	
Ball screw lead	20mm	10mm
Motor output	200W	200 W, with brake
Resolution	0.01mm	

Acceleration/deceleration time when the maximum speed is set: 0.36 sec. or over

	Stroke (mm)	Maximum speed (mm/s)
X-axis	700 ~ 800	1100
	900 ~ 1000	1000
	1100 ~ 1200	700
	1300	500
	1400	400
Z-axis	1500	300
	700	500
	800	400
	900 ~ 1000	300

Maximum Payload (kg) (Note 2)	Z-axis stroke									
	100mm	200mm	300mm	400mm	500mm	600mm	700mm	800mm	900mm	1000mm
	20.0	20.0	20.0	20.0	20.0	20.0	16.0	13.0	9.0	7.0

Note 2: Payload when a regeneration discharge unit (ABSU-2000) is used

**S: Right-handed**

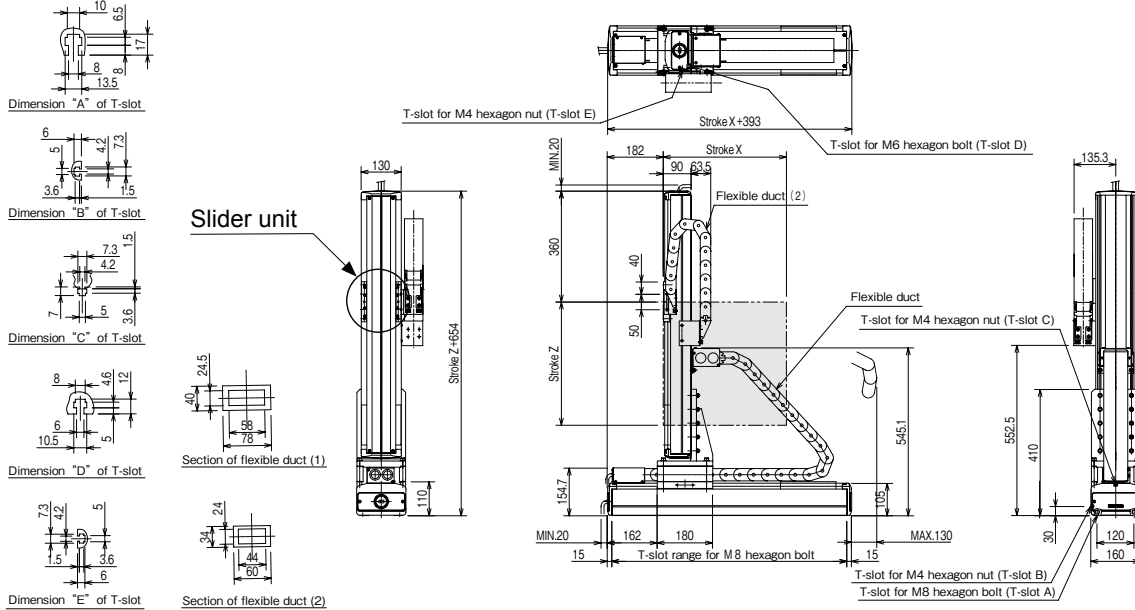

**M: Left-handed**

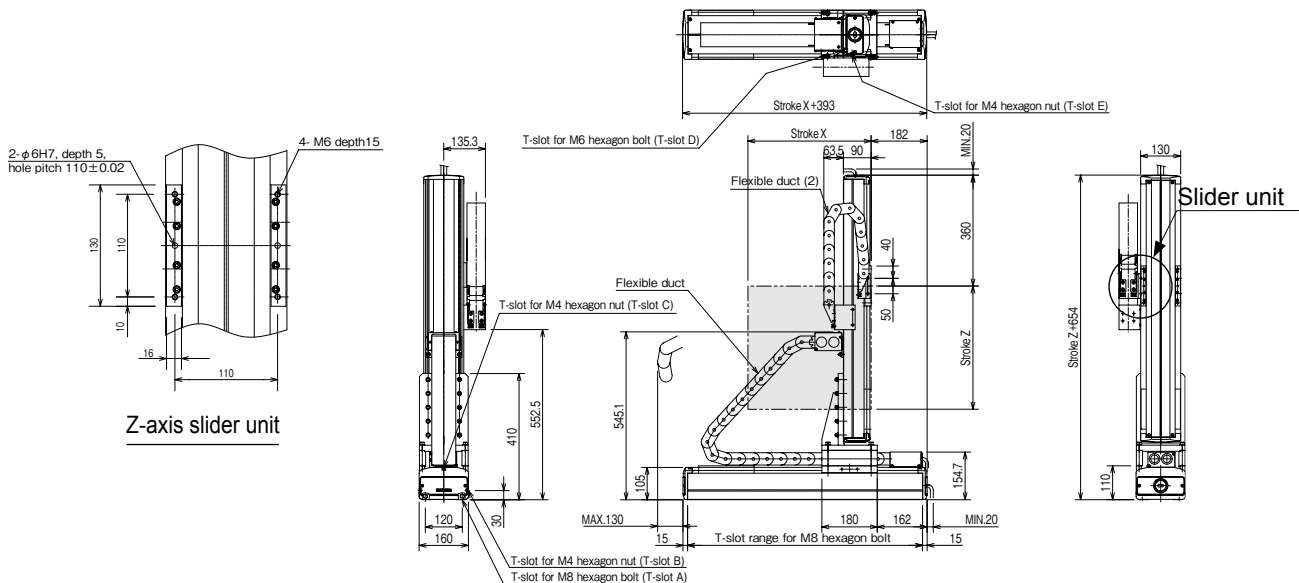

X-Z Flexible-duct Spec.

[Set designation]

**BA2 – A5 – B2B R A – 40 40 00 – OT 1 3**

**Ball screw type**

X-axis: Ball screw driven  
Motor straight  
Z-axis: Ball screw driven  
Motor straight

Note 1: When the stroke is as given below, the maximum speed differs.

Combined operation	Axis 1 stroke	Axis 2 stroke	Controller	Cable length
R: Right-handed	10 : 100mm	10 : 100mm	0: None	3 : 3m 9 : 9m
L: Left-handed	90 : 900mm	90 : 900mm	1: CA20-M10	5 : 5m B : 11m
	A0 : 1000mm	A0 : 1000mm	2: CA10-M00B	7 : 7m D : 13m
	F0 : 1500mm		3: CA10-M01B	

[Specifications]

	X-axis	Z-axis
Type of axis	BB50F-ST-M20N- □ 0	BB30F-ST-M10B- □ 0
Stroke (in increments of 100 mm)	200 ~ 1500mm	100 ~ 1000mm
Maximum speed	1,200 mm/s (Note 1)	600 mm/s (Note 1)
Positioning repeatability	±0.01mm	
Ball screw lead	20mm	10mm
Motor output	200W	200 W, with brake
Resolution	0.01mm	

Acceleration/deceleration time when the maximum speed is set: 0.36 sec. or over

	Stroke (mm)	Maximum speed (mm/s)
X-axis	700 ~ 800	1100
	900 ~ 1000	1000
	1100 ~ 1200	700
	1300	500
	1400	400
Z-axis	1500	300
	700	500
	800	400
	900 ~ 1000	300

Maximum Payload (kg) (Note 2)	Z-axis stroke									
	100mm	200mm	300mm	400mm	500mm	600mm	700mm	800mm	900mm	1000mm
	20.0	20.0	20.0	20.0	20.0	20.0	16.0	13.0	9.0	7.0

Note 2: Payload when a regeneration discharge unit (ABSU-2000) is used

R: Right-handed

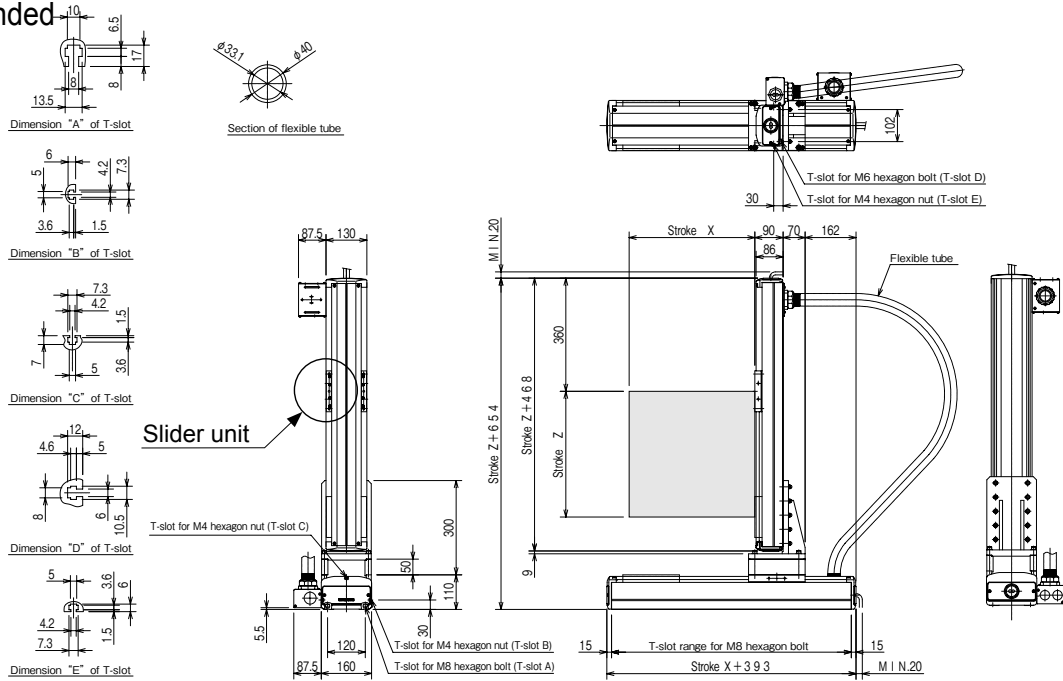

L: Left-handed

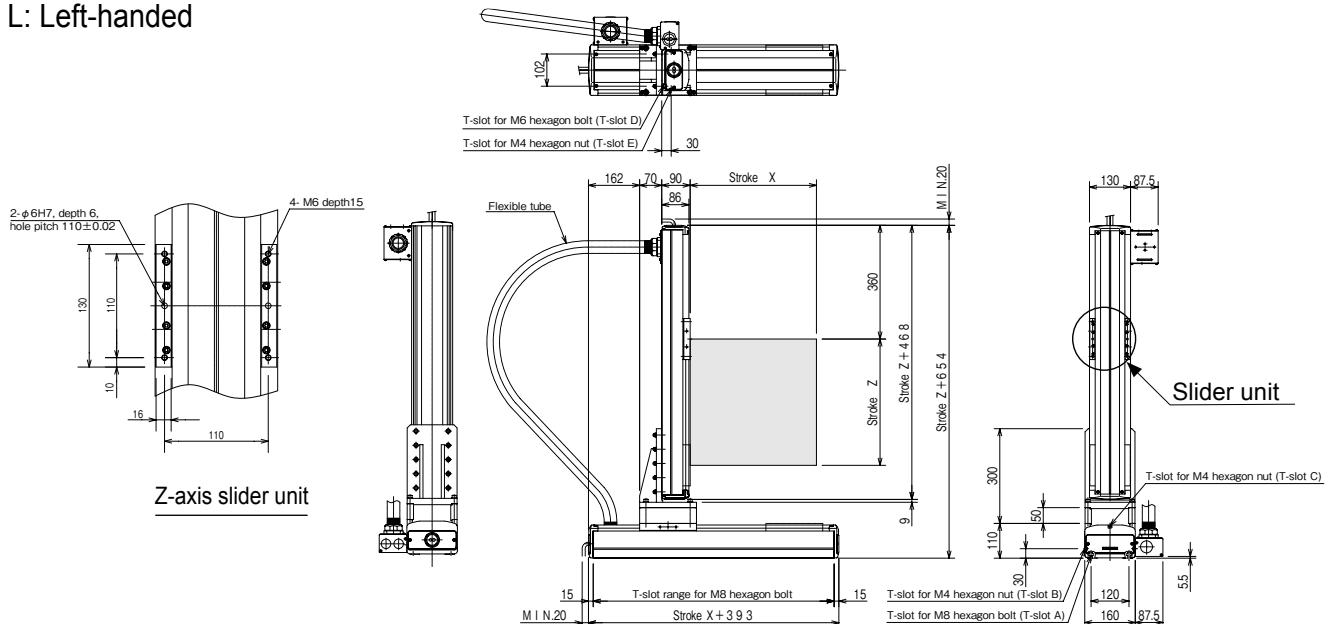



[Set designation]

**BA2 – A5 – B2C R A – 40 40 00 – OT 1 3**

Combined operation	Axis 1 stroke	Axis 2 stroke	Controller	Cable length
R: Right-handed L: Left-handed	20 : 200mm 90 : 900mm A0 : 1000mm F0 : 1500mm	20 : 200mm 90 : 900mm A0 : 1000mm	0: None 1: CA20-M10 2: CA10-M00B 3: CA10-M01B	3 : 3m 9 : 9m 5 : 5m B : 11m 7 : 7m D : 13m

**Ball screw type**

- X-axis: Ball screw driven  
Motor straight
- Z-axis: Ball screw driven  
Motor straight

Note 1: When the stroke is as given below, the maximum speed differs.

	Stroke (mm)	Maximum speed (mm/s)
X-axis	700 ~ 800	1100
	900 ~ 1000	1000
	1100 ~ 1200	700
	1300	500
	1400	400
Z-axis	700 ~ 800	550
	900 ~ 1000	500

[Specifications]

	X-axis	Z-axis
Type of axis	BB50F-ST-M20N- □ 0	BB50F-ST-M10B- □ 0
Stroke (in increments of 100 mm)	200 ~ 1500mm	200 ~ 1000mm
Maximum speed	1,200 mm/s (Note 1)	600 mm/s (Note 1)
Positioning repeatability	±0.01mm	
Ball screw lead	20mm	10mm
Motor output	200W	200 W, with brake
Resolution	0.01mm	

Acceleration/deceleration time when the maximum speed is set: 0.6 sec. or over

Maximum Payload (kg) (Note 2)	Z-axis stroke									
	200mm	300mm	400mm	500mm	600mm	700mm	800mm	900mm	1000mm	
	25.0	25.0 (23.0)	25.0 (21.0)	25.0 (19.0)	23.0 (17.0)	20.0 (15.0)	19.0 (13.0)	12.0 (11.0)	10.0	

Note 2: Payload when a regeneration discharge unit (ABSU-2000) is used.

When the X-axis speed exceeds 1,000 m/s, the values in parentheses are used for the maximum Payload.

**R: Right-handed**

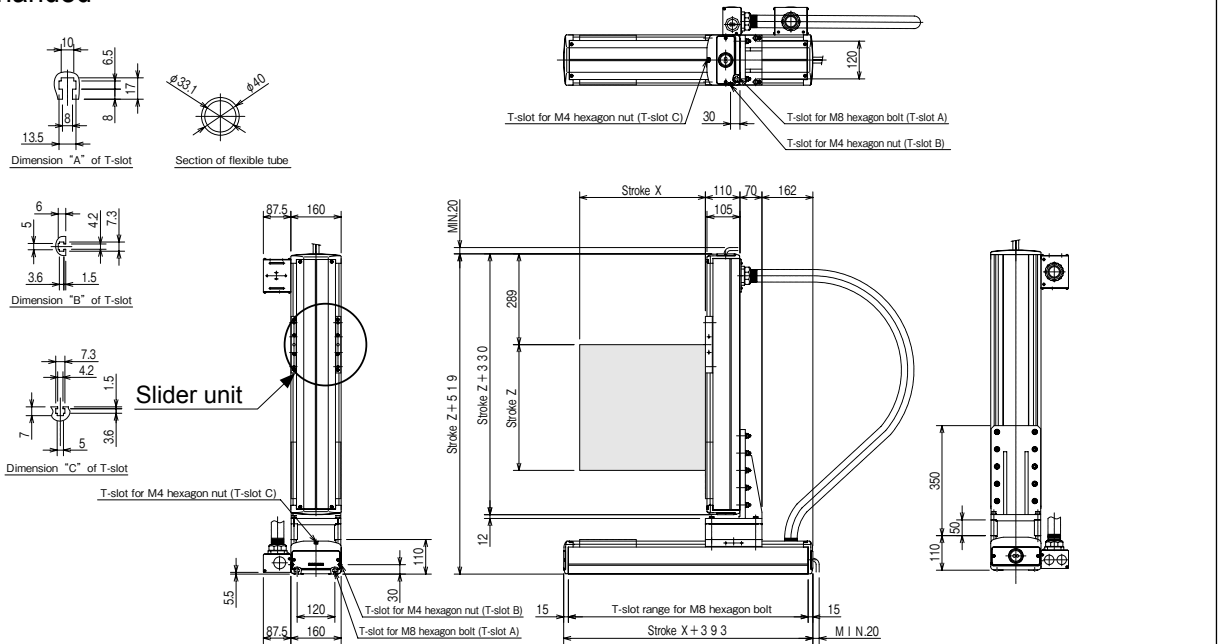

**L: Left-handed**

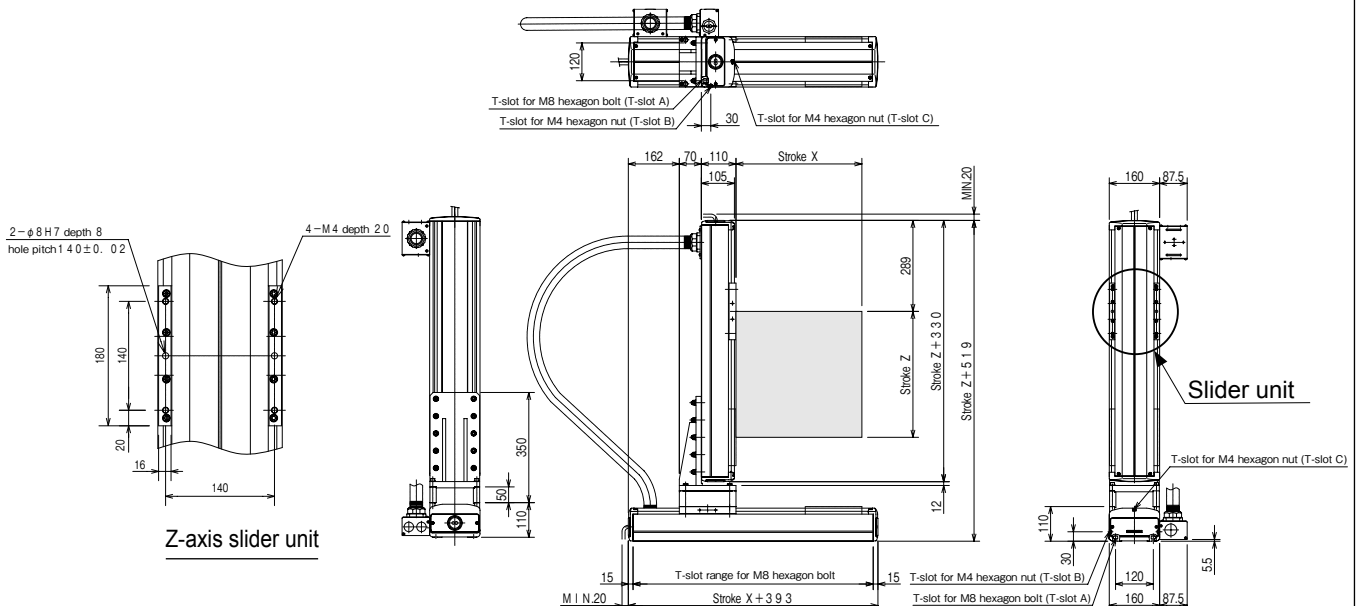

[Set designation]

**BA2 - L1 - B2A S S - 40 45 00 - OF 1 3**

Timing belt type

X-axis: Timing belt driven  
Side mounted motor  
Z-axis: Ball screw driven  
Motor straight

Combined operation	Axis 1 stroke	Axis 2 stroke	Controller	Cable length	
S: Right-handed M: Left-handed	10 : 100mm 90 : 900mm A0 : 1000mm H0 : 1700mm J0 : 1800mm	15 : 150mm 45 : 450mm	0: None 1: CA20-M10 2: CA10-M00B 3: CA10-M01B	3 : 3m 5 : 5m 7 : 7m	9 : 9m B : 11m D : 13m

[Specifications]

	X-axis	Z-axis
Type of axis	BB10E-B □ -M21N- □ 0	BB10E-ST-S10B- □ 5
Stroke (in increments of 100 mm)	100 ~ 1800mm	150 ~ 450mm
Maximum speed	1000mm/s	600mm/s
Positioning repeatability	±0.05mm	±0.01mm
Lead	21 mm (lead converted into ball screw)	10mm
Motor output	100W	100 W, with brake
Resolution	0.01mm	

Acceleration/deceleration time when the maximum speed is set: 0.5 sec. or over

Maximum Payload (kg)	Z-axis stroke			
	150mm	250mm	350mm	450mm
	7.0	6.0	4.0	2.0

S: Right-handed

The values in parentheses are applicable when the X-axis stroke is 1,100 mm or over.

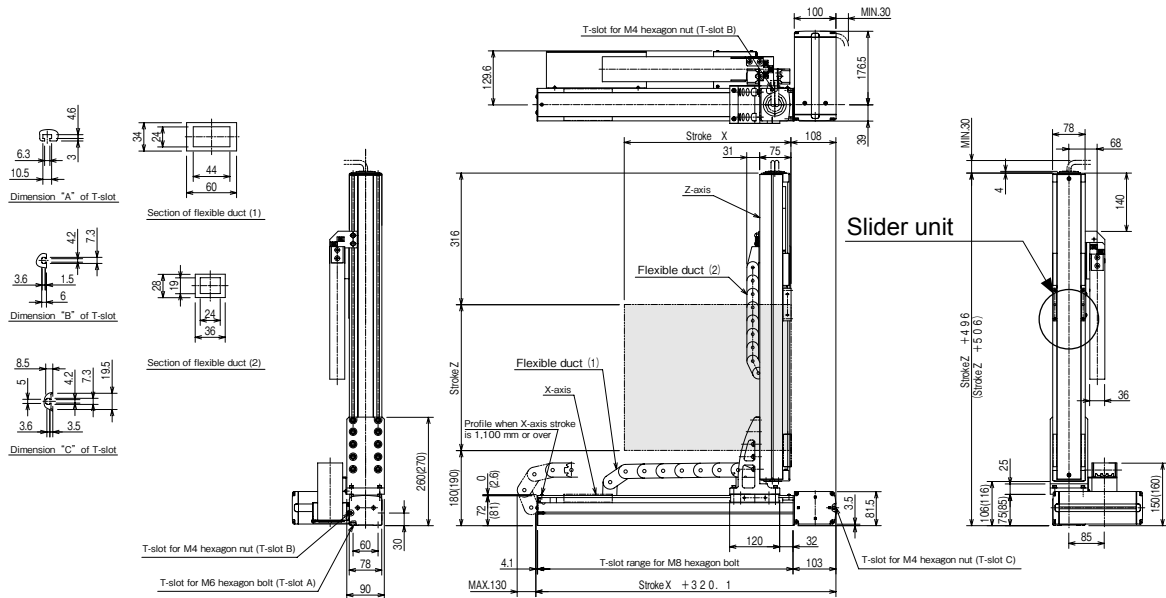

M: Left-handed

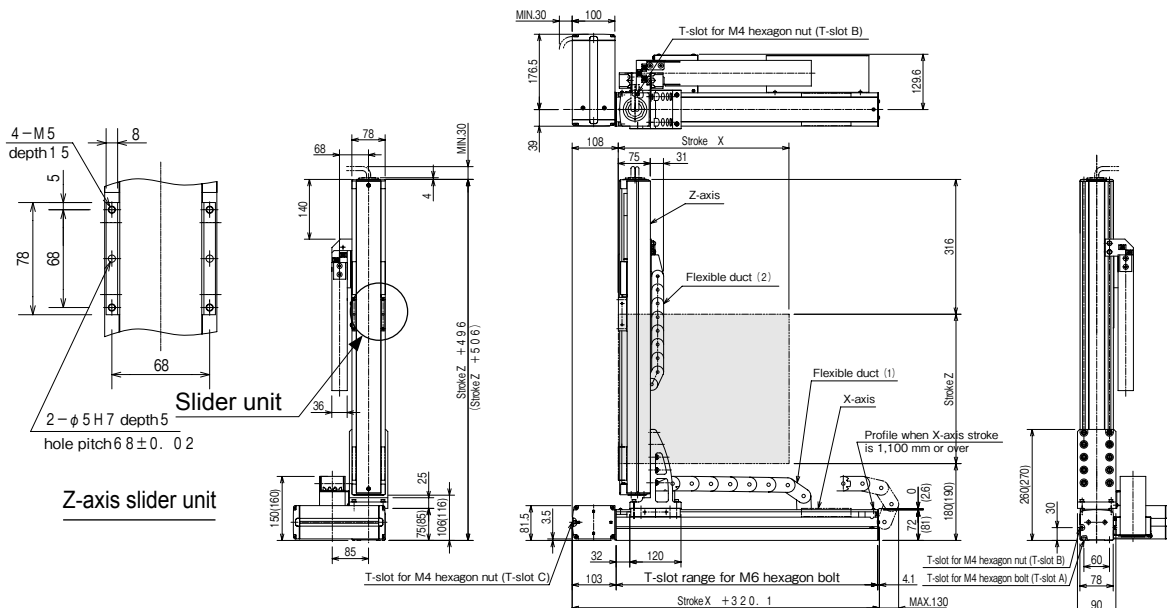

[Set designation]

**BA2 - L1 - B2B S S - 40 45 00 - OF 1 3**

Combined operation	Axis 1 stroke	Axis 2 stroke	Controller	Cable length	
S: Right-handed M: Left-handed	10 : 100mm └ 90 : 900mm A0 : 1000mm └ H0 : 1700mm J0 : 1800mm	15 : 150mm └ 45 : 450mm	0: None 1: CA20-M10 2: CA10-M00B 3: CA10-M01B	3 : 3m 5 : 5m 7 : 7m	9 : 9m B : 11m D : 13m

**Timing belt type**

- X-axis: Timing belt driven  
Side mounted motor
- Z-axis: Ball screw driven  
Motor straight

[Specifications]

	X-axis	Z-axis
Type of axis	BB10F-B □ -M21N- □ 0	BB10E-ST-S10B- □ 5
Stroke (in increments of 100 mm)	100 ~ 1800mm	150 ~ 450mm
Maximum speed	1000mm/s	600mm/s
Positioning repeatability	±0.05mm	±0.01mm
Lead	21 mm (lead converted into ball screw)	10mm
Motor output	200W	100 W, with brake
Resolution	0.01mm	

Acceleration/deceleration time when the maximum speed is set: 0.36 sec. or over

Maximum Payload (kg)	Z-axis stroke			
	150mm	250mm	350mm	450mm
	8.0	6.0	4.0	2.0

**S: Right-handed**

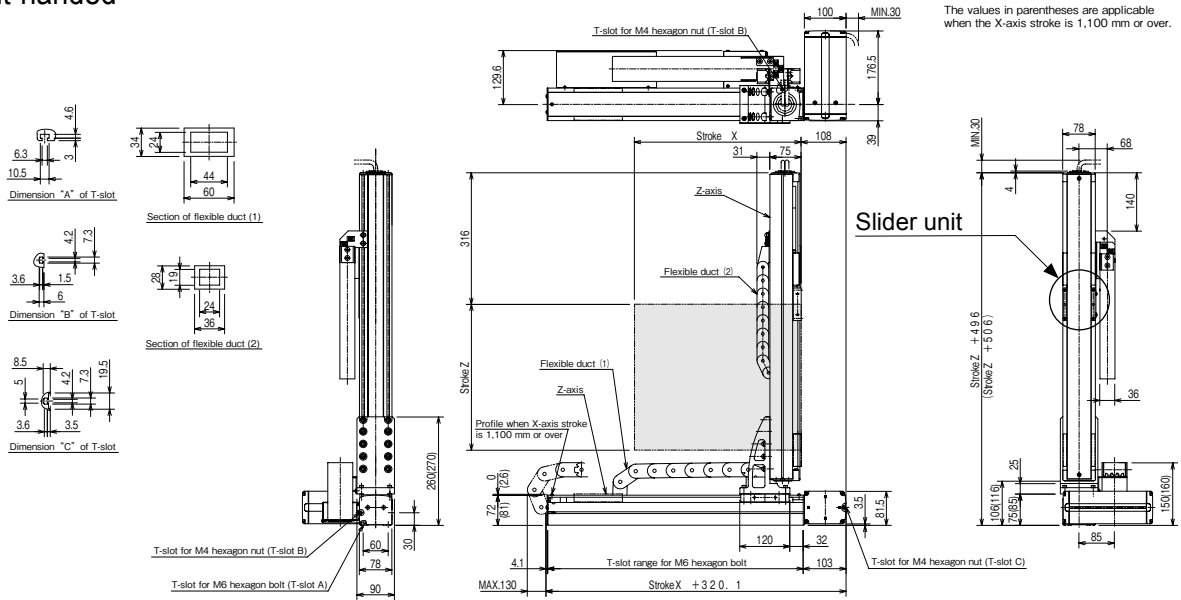

**M: Left-handed**

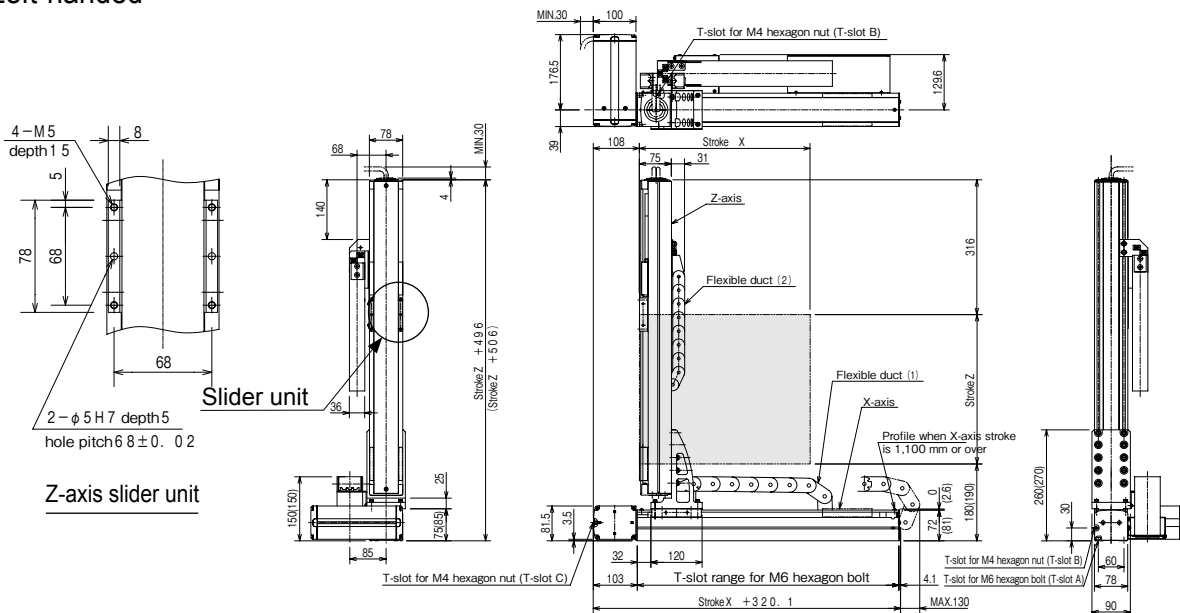

[Set designation]

**BA2 - L3 - B2A S S - 40 40 00 - OF 1 3**

Timing belt type

- X-axis: Timing belt driven  
Side mounted motor
- Z-axis: Ball screw driven  
Motor straight

Combined operation	Axis 1 stroke		Axis 2 stroke	Controller	Cable length	
S: Right-handed	10 : 100mm	J0 : 1800mm	10 : 100mm	0: None	3 : 3m	9 : 9m
M: Left-handed	90 : 900mm	N0 : 2200mm	70 : 700mm	1: CA20-M10	5 : 5m	B : 11m
	AO : 1000mm	PO : 2300mm		2: CA10-M00B	7 : 7m	D : 13m
	HO : 1700mm	RO : 2500mm		3: CA10-M01B		

[Specifications]

	X-axis	Z-axis
Type of axis	BB30E-B <input type="checkbox"/> -M21N- <input type="checkbox"/> 0	BB10E-ST-M10B- <input type="checkbox"/> 0
Stroke (in increments of 100 mm)	100 ~ 2500mm	100 ~ 700mm
Maximum speed	1000mm/s	600 mm/s (Note 1)
Positioning repeatability	±0.05mm	±0.01mm
Lead	21 mm (lead converted into ball screw)	10mm
Motor output	100W	100 W, with brake
Resolution	0.01mm	

Note 1: When the stroke is as given below, the maximum speed differs.

	Stroke (mm)	Maximum speed (mm/s)
Z-axis	700	500

Acceleration/deceleration time when the maximum speed is set: 0.5 sec. or over

Maximum Payload (kg)	Z-axis stroke						
	100mm	200mm	300mm	400mm	500mm	600mm	700mm
	5.0	4.0	4.0	3.0	2.0	2.0	1.0

S: Right-handed

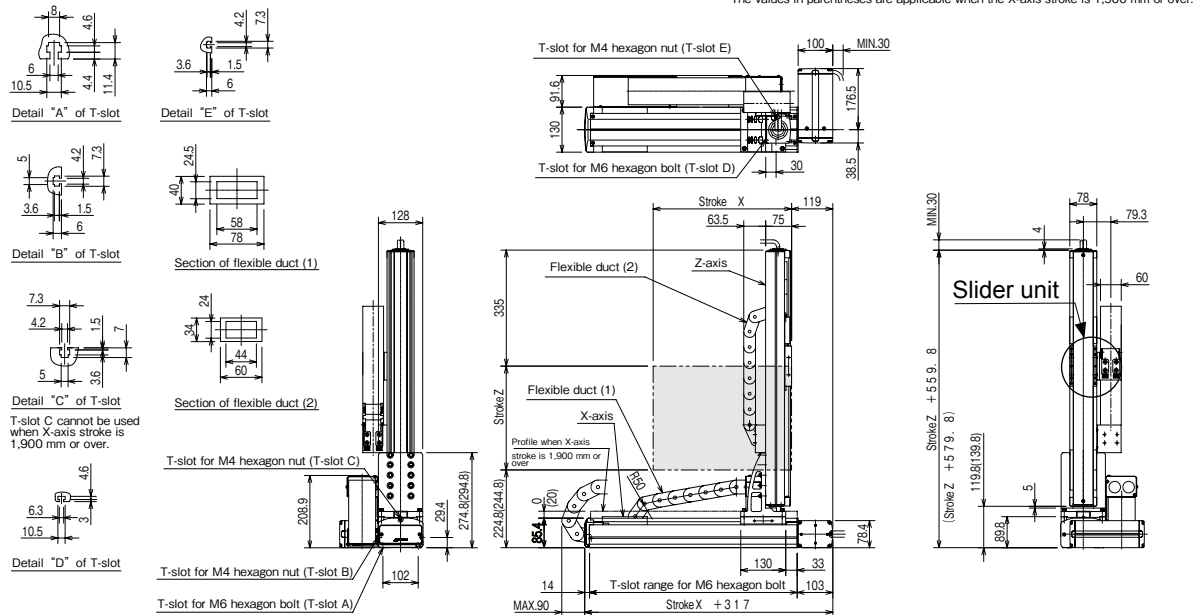

M: Left-handed

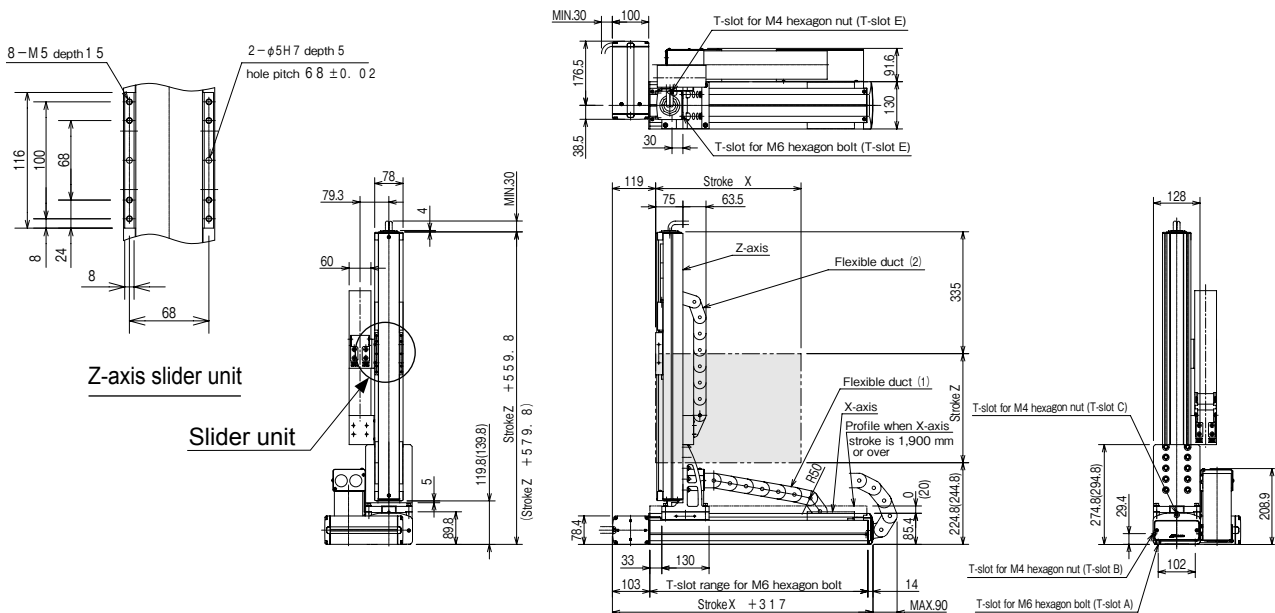

[Set designation]

**BA2 - L3 - B2B S S - 40 40 00 - OF 1 3**

Combined operation	Axis 1 stroke	Axis 2 stroke	Controller	Cable length
S: Right-handed M: Left-handed	10 : 100mm ? : 1800mm	10 : 100mm 90 : 900mm	0: None 1: CA20-M10 2: CA10-M00B 3: CA10-M01B	3 : 3m 9 : 9m 5 : 5m B : 11m 7 : 7m D : 13m
	90 : 900mm A0 : 1000mm ? : 2300mm H0 : 1700mm R0 : 2500mm			

**Timing belt type**

- X-axis: Timing belt driven  
Side mounted motor
- Z-axis: Ball screw driven  
Motor straight

[Specifications]

	X-axis	Z-axis
Type of axis	BB30F-B □ -M21N- □ 0	BB10E-ST-M10B- □ 0
Stroke (in increments of 100 mm)	100 ~ 2500mm	100 ~ 900mm
Maximum speed	1000mm/s	600 mm/s (Note 1)
Positioning repeatability	±0.05mm	±0.01mm
Lead	21 mm (lead converted into ball screw)	10mm
Motor output	100W	100 W, with brake
Resolution	0.01mm	

Acceleration/deceleration time when the maximum speed is set: 0.36 sec. or over

Note 1: When the stroke is as given below, the maximum speed differs.

	Stroke (mm)	Maximum speed (mm/s)
Z-axis	700	500
	800	400
	900	300

Maximum Payload (kg) (Note 2)	Z-axis stroke								
	100mm	200mm	300mm	400mm	500mm	600mm	700mm	800mm	900mm
	12.0	12.0	12.0	12.0	12.0	10.0	4.0	2.0	2.0

Note 2: Payload when a regeneration discharge unit (ABSU-2000) is used.

**S: Right-handed**

The values in parentheses are applicable when the X-axis stroke is 1,900 mm or over.

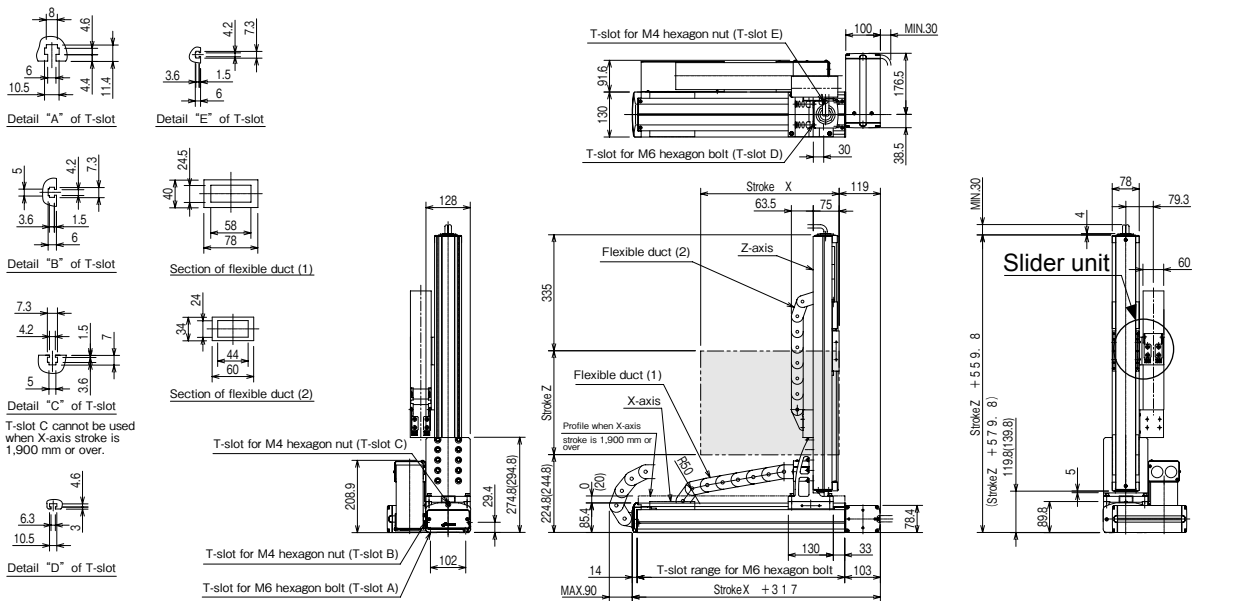

**M: Left-handed**

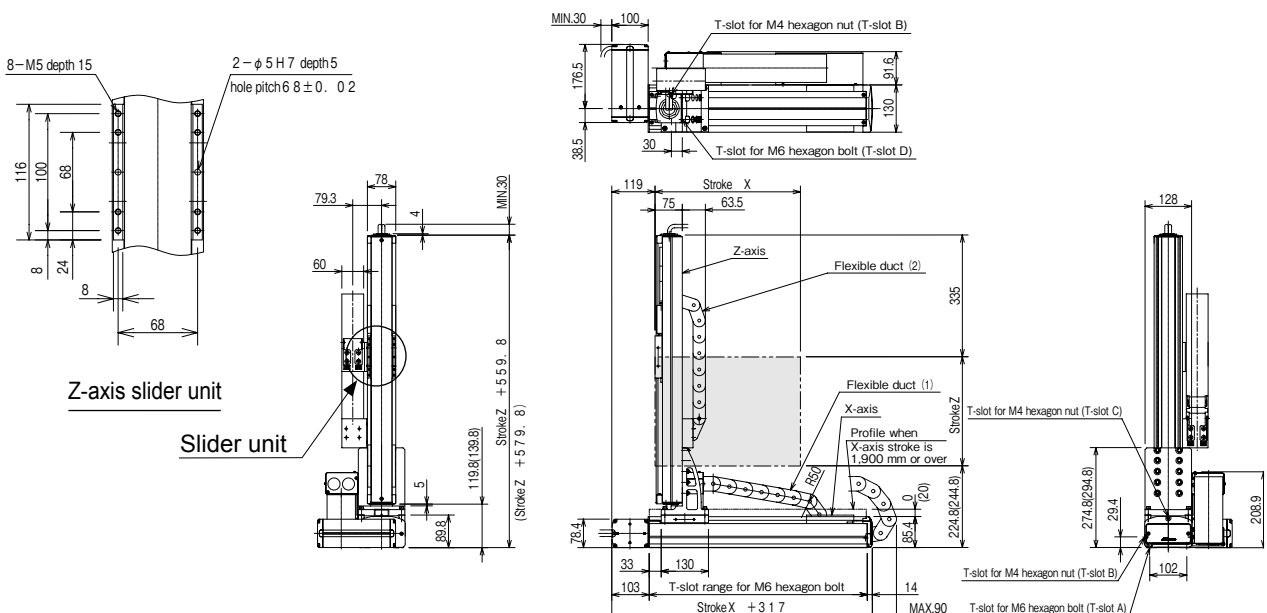



[Set designation]

**BA2 - L5 - B2A S S - 40 40 00 - OF 1 3**

Timing belt type

- X-axis: Timing belt driven  
Side mounted motor
- Z-axis: Ball screw driven  
Motor straight

Combined operation	Axis 1 stroke	Axis 2 stroke	Controller	Cable length
S: Right-handed	20 : 200mm	J0 : 1800mm	0: None	3 : 3m 9 : 9m
M: Left-handed	?	?	1: CA20-M10	5 : 5m B : 11m
	90 : 900mm	NO : 2200mm	2: CA10-M00B	7 : 7m D : 13m
	A0 : 1000mm	PO : 2300mm	3: CA10-M01B	
	?	?		
	H0 : 1700mm	RO : 2500mm		

[Specifications]

	X-axis	Z-axis
Type of axis	BB50F-B <input type="checkbox"/> -M21N- <input type="checkbox"/> 0	BB30E-ST-M10B- <input type="checkbox"/> 0
Stroke (in increments of 100 mm)	200 ~ 2500mm	100 ~ 1000mm
Maximum speed	1000mm/s	600 mm/s (Note 1)
Positioning repeatability	±0.05mm	±0.01mm
Lead	21 mm (lead converted into ball screw)	10mm
Motor output	200W	100 W, with brake
Resolution	0.01mm	

Note 1: When the stroke is as given below, the maximum speed differs.

	Stroke (mm)	Maximum speed (mm/s)
Z-axis	700	500
	800	400
	900 ~ 1000	300

Acceleration/deceleration time when the maximum speed is set: 0.36 sec. or over

Maximum Payload (kg) (Note 2)	Z-axis stroke									
	100mm	200mm	300mm	400mm	500mm	600mm	700mm	800mm	900mm	1000mm
	12.0	12.0	12.0	12.0	12.0	12.0	12.0	12.0	12.0	8.0

Note 2: Payload when a regeneration discharge unit (ABSU-2000) is used.

S: Right-handed

The values in parentheses are applicable when the X-axis stroke is 1,900 mm or over.

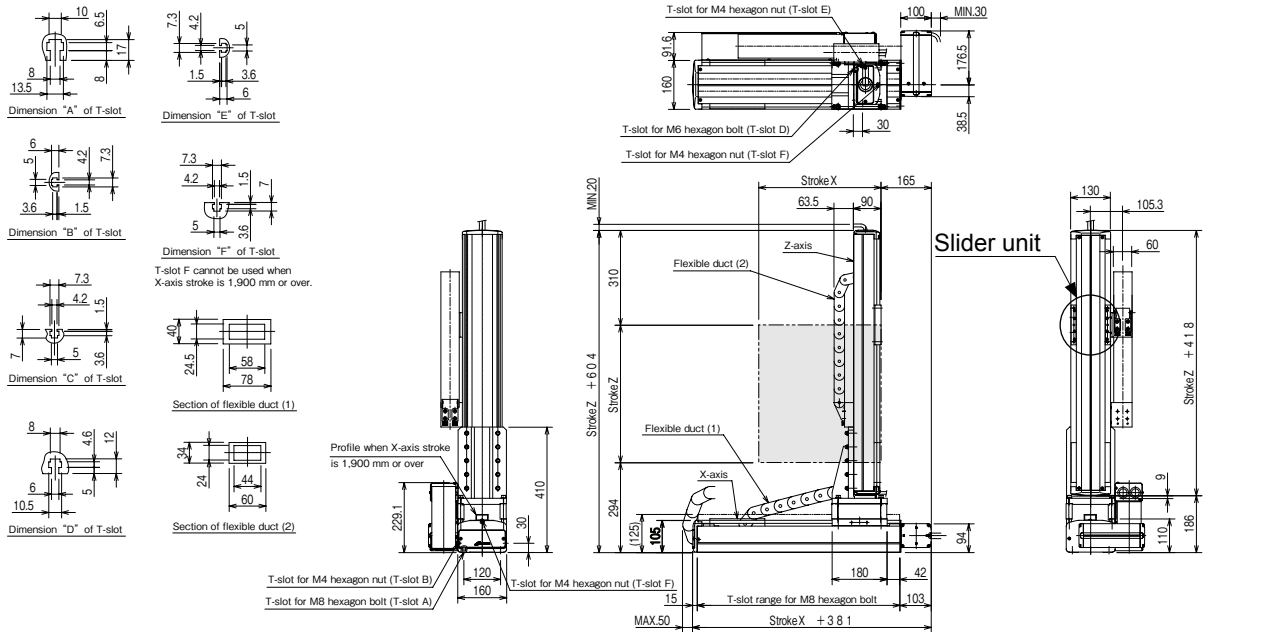

M: Left-handed

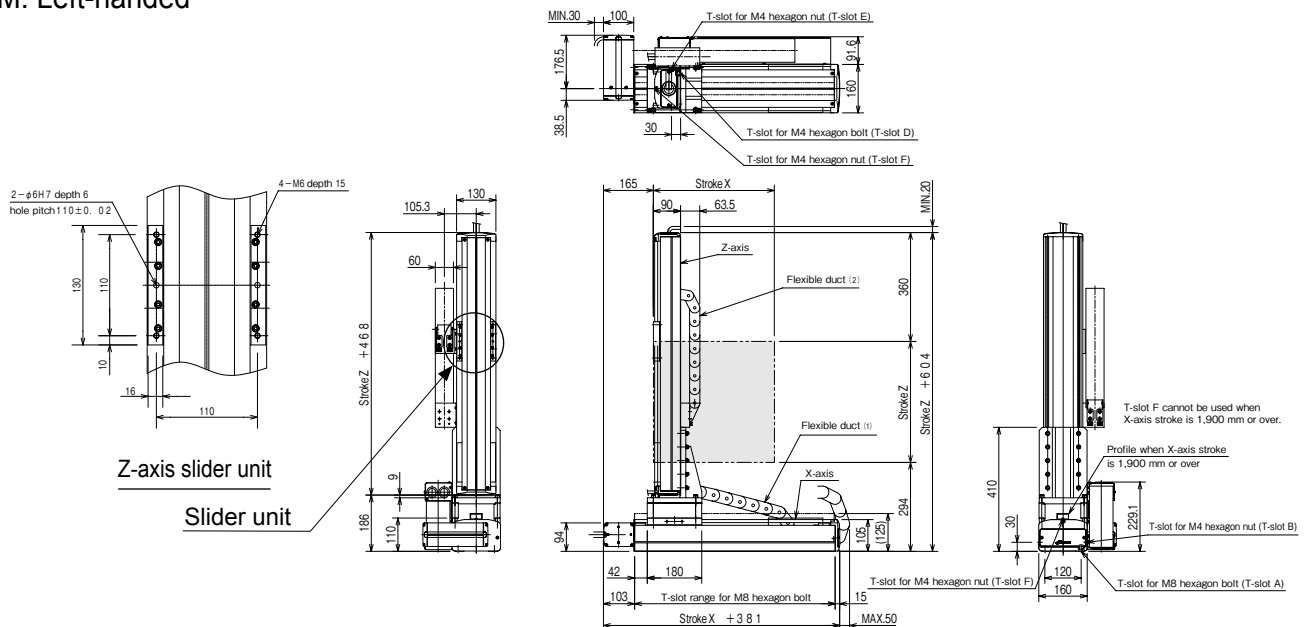

[Set designation]

**BA2 - L5 - B2B S S - 40 40 00 - OF 1 3**

Combined operation	Axis 1 stroke	Axis 2 stroke	Controller	Cable length
S: Right-handed	20 : 200mm	J0 : 1800mm	0: None	3 : 3m 9 : 9m
M: Left-handed	90 : 900mm	NO : 2200mm	1: CA20-M10	5 : 5m B : 11m
	A0 : 1000mm	PO : 2300mm	2: CA10-M00B	7 : 7m D : 13m
	H0 : 1700mm	RO : 2500mm	3: CA10-M01B	

**Timing belt type**

- X-axis: Timing belt driven  
Side mounted motor
- Z-axis: Ball screw driven  
Motor straight

[Specifications]

	X-axis	Z-axis
Type of axis	BB50F-B □ -M21N- □ 0	BB30F-ST-M10B- □ 0
Stroke (in increments of 100 mm)	200 ~ 2500mm	100 ~ 1000mm
Maximum speed	1000mm/s	600 mm/s (Note 1)
Positioning repeatability	±0.05mm	±0.01mm
Lead	21 mm (lead converted into ball screw)	10mm
Motor output	200W	200 W, with brake
Resolution	0.01mm	

Acceleration/deceleration time when the maximum speed is set: 0.36 sec. or over

Maximum Payload (kg) (Note 2)	Z-axis stroke									
	100mm	200mm	300mm	400mm	500mm	600mm	700mm	800mm	900mm	1000mm
	20.0	20.0	20.0	19.0	18.0	17.0	16.0	13.0	9.0	7.0

Note 2: Payload when a regeneration discharge unit (ABSU-2000) is used.

Note 1: When the stroke is as given below, the maximum speed differs.

	Stroke (mm)	Maximum speed (mm/s)
Z-axis	700	500
	800	400
	900 ~ 1000	300

**S: Right-handed**

The values in parentheses are applicable when the X-axis stroke is 1,900 mm or over.

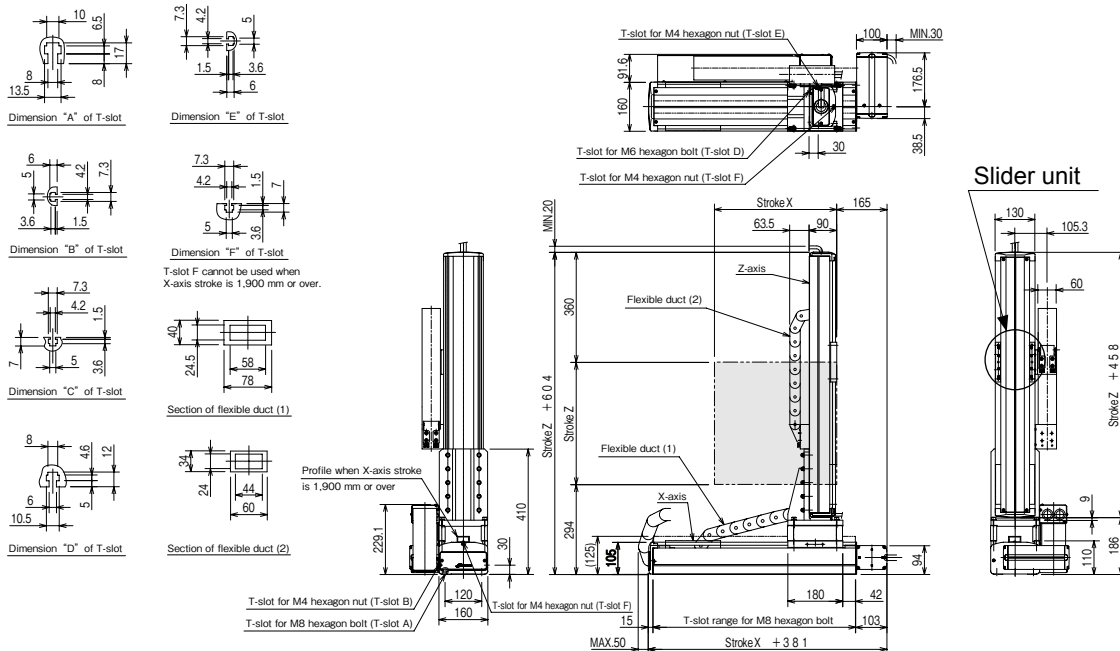

**M: Left-handed**

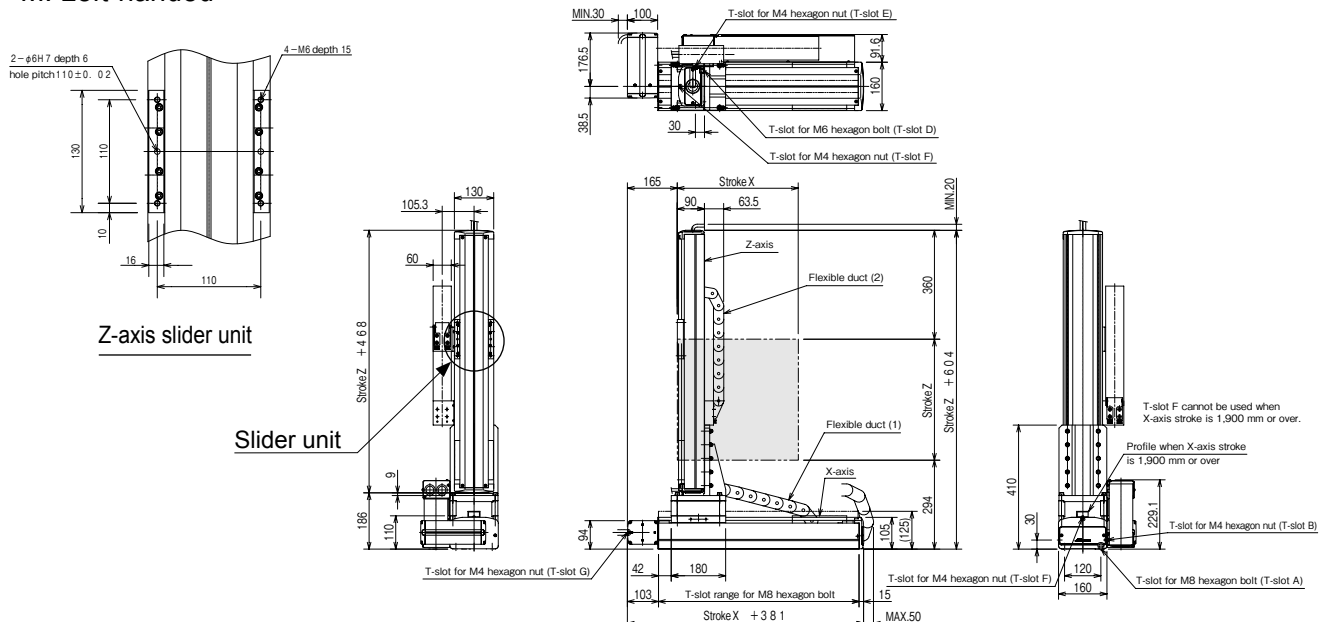

[Set designation]

**BA2 – K7 – H2A R A – 40 40 00 – 00 1 3**

Combined operation  
R: Right-handed  
L: Left-handed

Axis 1 stroke  
05 : 50mm  
60 : 600mm

Axis 2 stroke  
05 : 50mm  
50 : 500mm

Controller  
0: None  
1: CA20-M10  
2: CA10-M00B  
3: CA10-M01B

Cable length  
3 : 3m 9 : 9m  
5 : 5m B : 11m  
7 : 7m D : 13m

Ball screw type

Y-axis: Ball screw driven  
Motor straight  
Z-axis: Ball screw driven  
Motor straight

Note 1: When the stroke is as given below, the maximum speed differs.

	Stroke (mm)	Maximum speed (mm/s)
Y-axis	450 ~ 500	600
	550 ~ 600	400
Z-axis	450 ~ 500	600

[Specifications]

	Y-axis	Z-axis
Type of axis	BB07D-ST-M12N-□□	BB05D-ST-M12B-□□
Stroke (in increments of 50 mm)	50 ~ 600mm	50 ~ 500mm
Maximum speed	800mm/s (Note 1)	800mm/s (Note 1)
Positioning repeatability	±0.02mm	
Ball screw lead	12mm	12mm
Motor output	50W	50 W, with brake
Resolution	0.01mm	

Acceleration/deceleration time when the maximum speed is set: 0.3 sec. or over

Maximum Payload (kg)	Z-axis stroke									
	50mm	100mm	150mm	200mm	250mm	300mm	350mm	400mm	450mm	500mm
	3.0	3.0	3.0	3.0	3.0	3.0	2.0	2.0	1.0	1.0

R: Right-handed

Stroke Y (BA07)	50	100	150	200	250	300	350	400	450	500	550	600
No. of holes A	4	4	6	6	8	8	10	10	12	12	14	14
Hole-to-hole pitch B	1	1	2	2	3	3	4	4	5	5	6	6

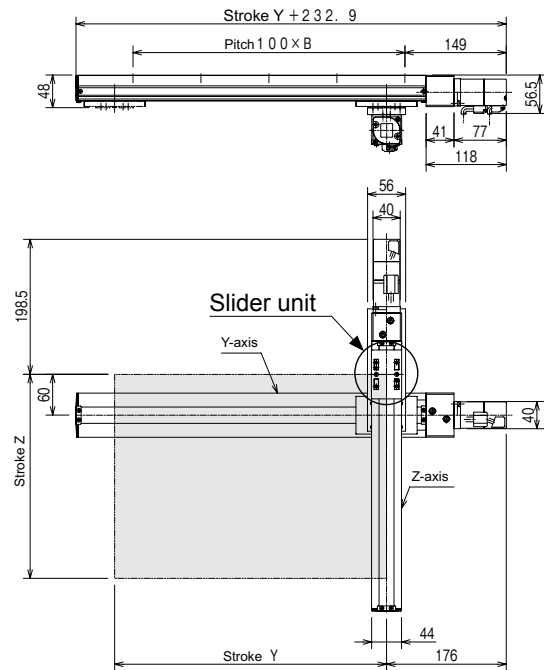
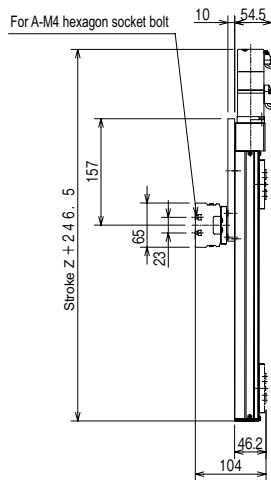

L: Left-handed

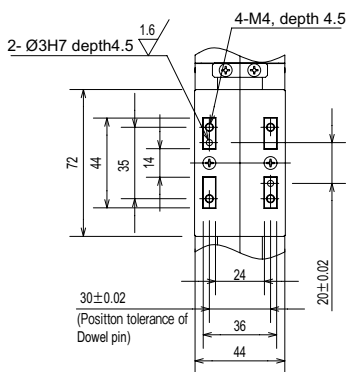

Z-axis slider unit

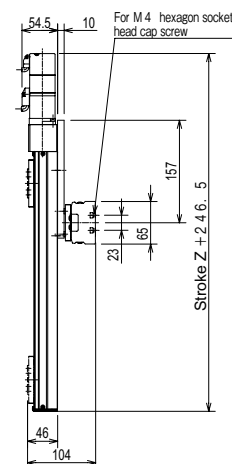
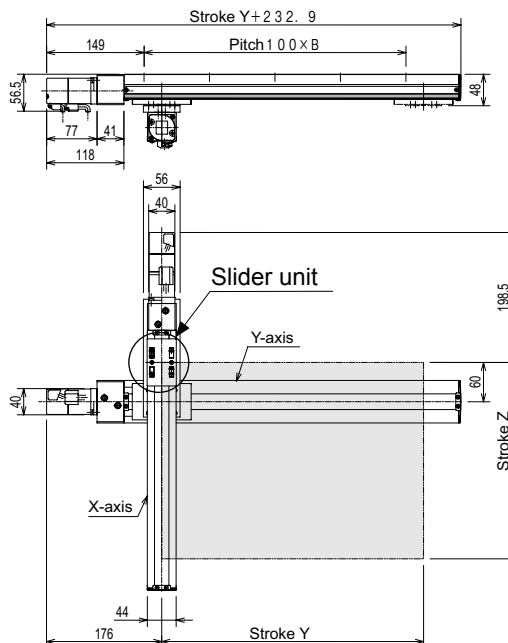

[Set designation]

**BA2 - A1 - H2C R A - 45 40 00 - OF 1 3**

Combined operation R: Right-handed L: Left-handed	Axis 1 stroke 15 : 150mm 95 : 950mm A5 : 1050mm	Axis 2 stroke 05 : 50mm 60 : 600mm	Controller 0: None 1: CA20-M10 2: CA10-M00B 3: CA10-M01B	Cable length 3 : 3m 9 : 9m 5 : 5m B : 11m 7 : 7m D : 13m
---	--	--	--	---

Ball screw type

Y-axis: Ball screw driven  
Motor straight  
Z-axis: Ball screw driven  
Motor straight

[Specifications]

Type of axis	Y-axis: BB10E-ST-S20N-□ 5	Z-axis: BB07D-ST-M12B-□ □
Stroke (in increments of 100 mm for Y-axis, 50mm for Z-axis)	150 ~ 1050mm	50 ~ 600mm
Maximum speed	1200mm/s (Note 1)	800mm/s (Note 1)
Positioning repeatability	±0.02mm	
Ball screw lead	20mm	12mm
Motor output	100W	50 W, with brake
Resolution	0.01mm	

Note 1: When the stroke is as given below, the maximum speed differs.

	Stroke (mm)	Maximum speed (mm/s)
Y-axis	750	1000
	850	800
	950 ~ 1050	600
Z-axis	450 ~ 500	600
	550 ~ 600	400

Acceleration/deceleration time when the maximum speed is set: 0.36 sec. or over

Maximum Payload (kg)	Z-axis stroke											
	50mm	100mm	150mm	200mm	250mm	300mm	350mm	400mm	450mm	500mm	550mm	600mm
	4.0	4.0	4.0	4.0	4.0	4.0	4.0	4.0	4.0	4.0	2.5	2.5

R: Right-handed

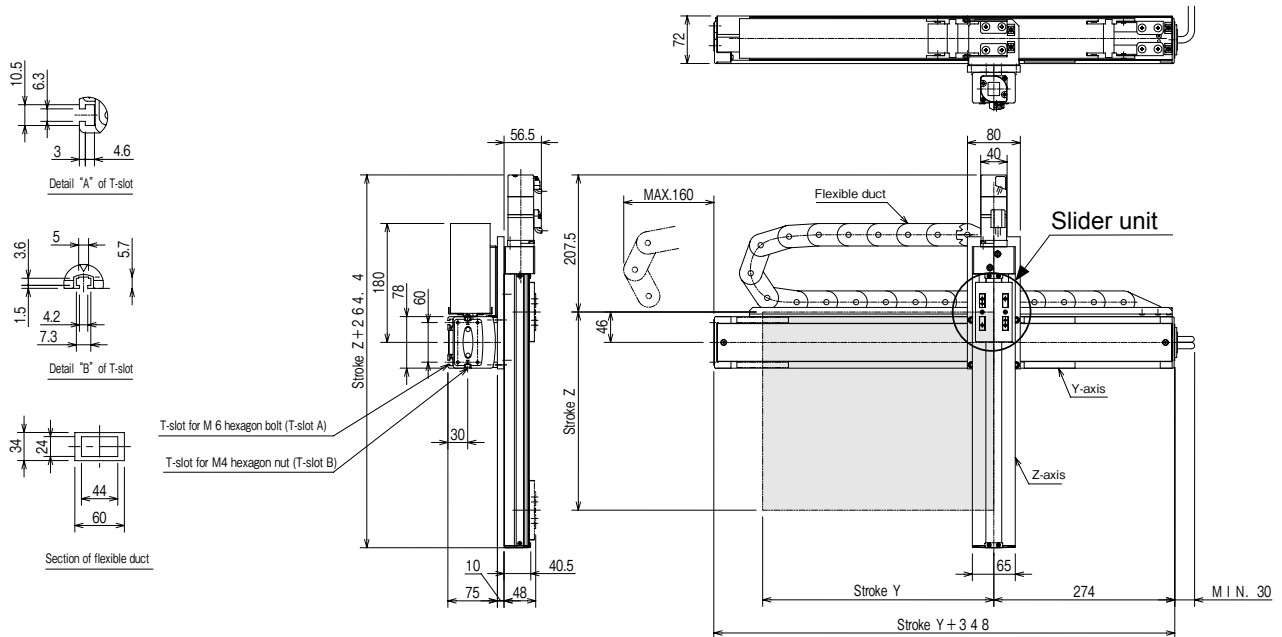

L: Left-handed

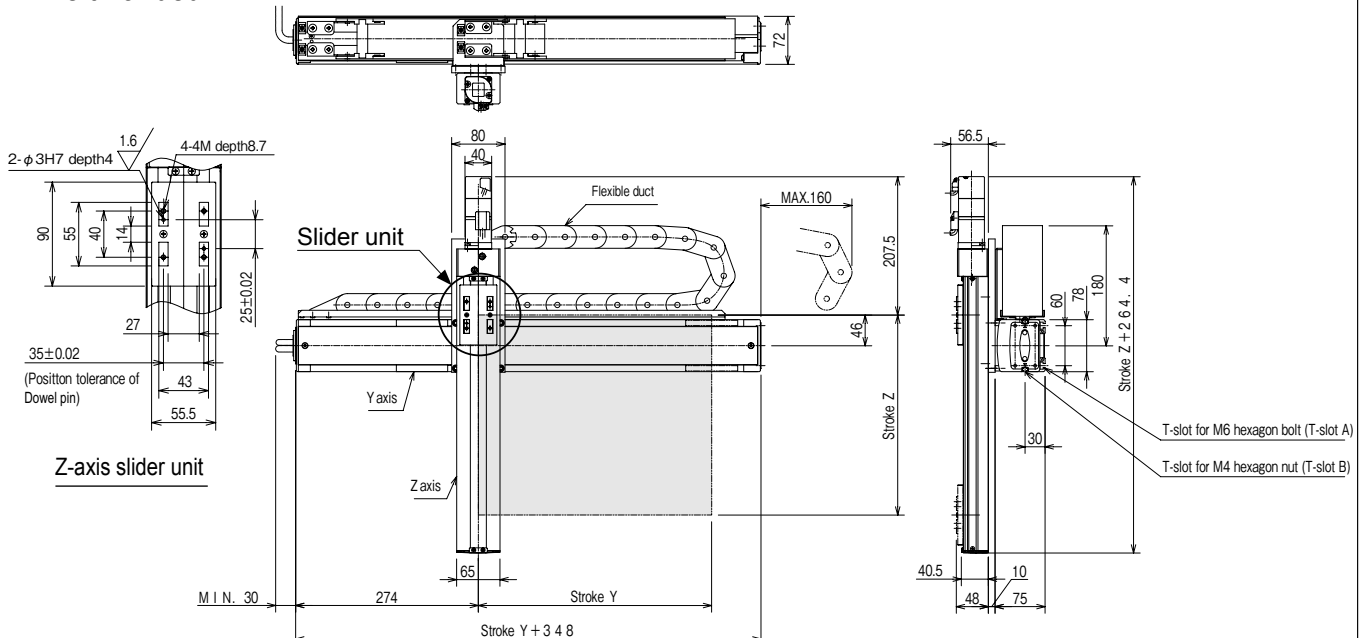

[Set designation]

**BA2 – A1 – H2A R C – 40 45 00 – OF 1 3**

Ball screw type

- Y-axis: Ball screw driven  
Motor straight
- Z-axis: Ball screw driven  
Side mounted moto

Combined operation R: Right-handed L: Left-handed	Axis 1 stroke 10 : 100mm 90 : 900mm A0 : 1000mm	Axis 2 stroke 15 : 150mm 55 : 550mm	Controller 0: None 1: CA20-M10 2: CA10-M00B 3: CA10-M01B	Cable length 3 : 3m 9 : 9m 5 : 5m B : 11m 7 : 7m D : 13m
---	--	---	--	---

[Specifications]

	Y-axis	Z-axis
Type of axis	BB10E-ST-M20N-□ 0	BB10E-U □ -S10B-□ 5
Stroke (in increments of 100 mm)	100 ~ 1000mm	150 ~ 550mm
Maximum speed	1200mm/s (Note 1)	600mm/s
Positioning repeatability	±0.01mm	
Ball screw lead	20mm	10mm
Motor output	100W	100 W, with brake
Resolution	0.01mm	

Note 1: When the stroke is as given below, the maximum speed differs.

	Stroke (mm)	Maximum speed (mm/s)
Y-axis	700	1000
	800	800
	900 ~ 1000	600

Acceleration/deceleration time when the maximum speed is set: 0.36 sec. or over

Maximum Payload (kg) (Note 2)	Z-axis stroke				
	150mm	250mm	350mm	450mm	550mm
	8.0	8.0	6.5	5.0	3.0

Note 2: Payload when a regeneration discharge unit (ABSU-2000) is used.

R: Right-handed

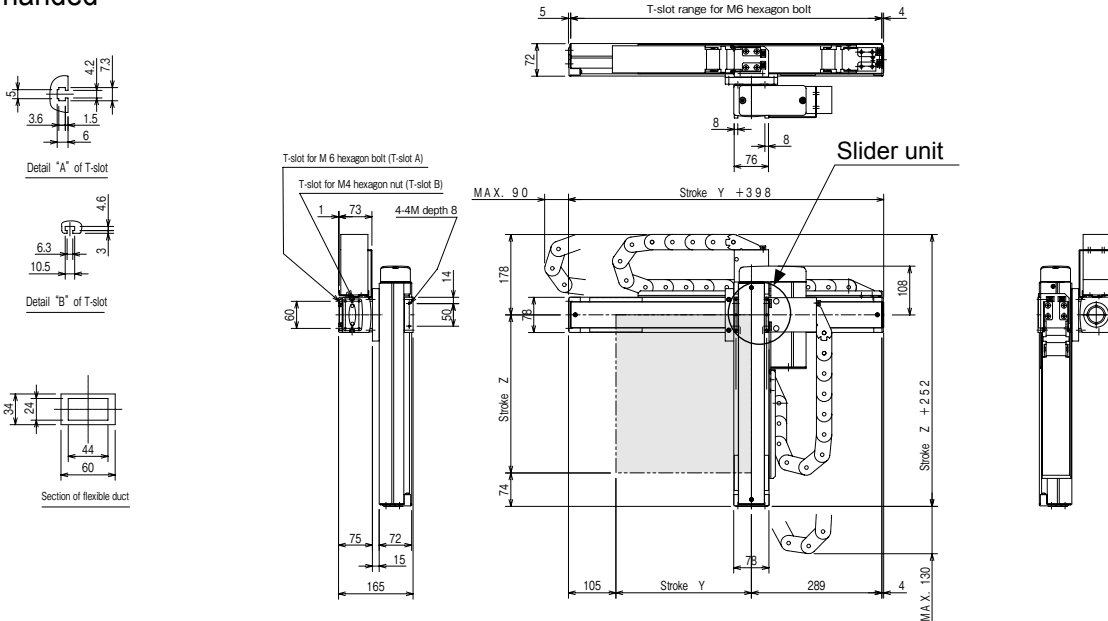

L: Left-handed

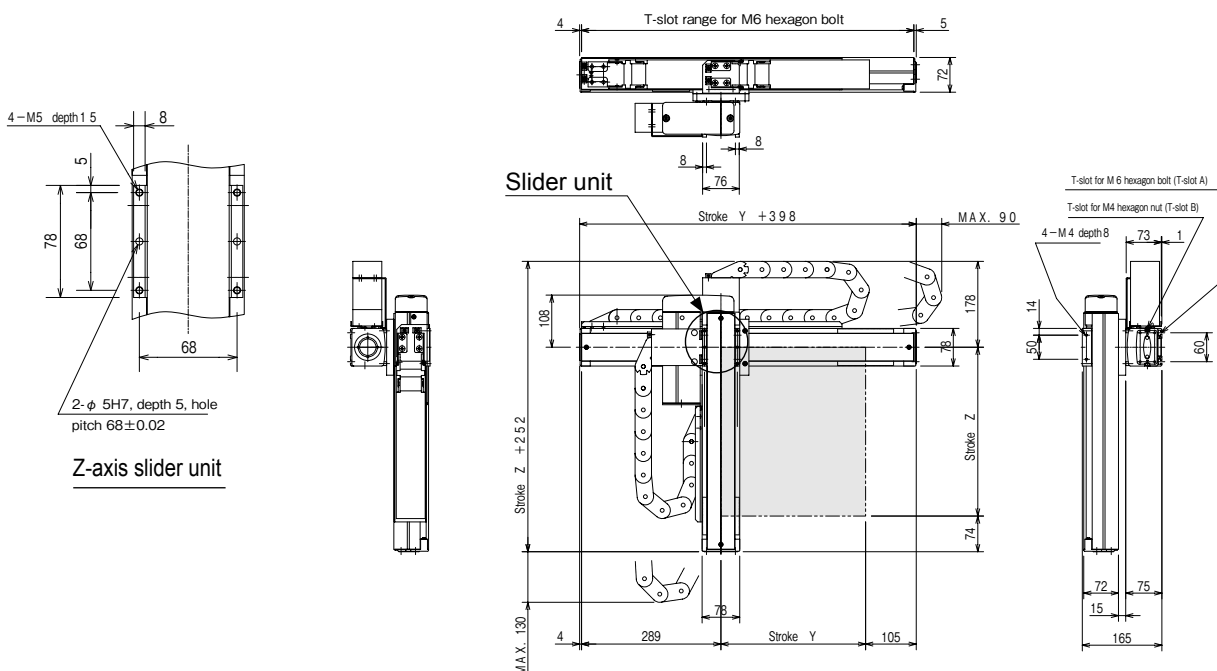

Y-Z Flexible-duct Spec.

[Set designation]

**BA2 - A1 - H2A R C - 40 45 00 - OT 1 3**

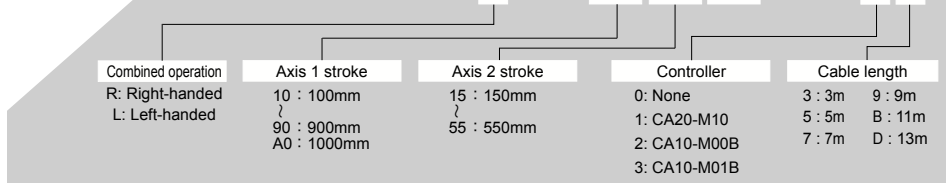

Ball screw type

- Y-axis: Ball screw driven  
Motor straight
- Z-axis: Ball screw driven  
Side mounted moto

[Specifications]

	Y-axis	Z-axis
Type of axis	BB10E-ST-M20N-□ 0	BB10E-U □ -S10B-□ 5
Stroke (in increments of 100 mm)	100 ~ 1000mm	150 ~ 550mm
Maximum speed	1200mm/s (Note 1)	600mm/s
Positioning repeatability	±0.01mm	
Ball screw lead	20mm	10mm
Motor output	100W	100 W, with brake
Resolution	0.01mm	

Note 1: When the stroke is as given below, the maximum speed differs.

	Stroke (mm)	Maximum speed (mm/s)
Y-axis	700	1000
	800	800
	900 ~ 1000	600

Acceleration/deceleration time when the maximum speed is set: 0.36 sec. or over

Maximum Payload (kg) (Note 2)	Z-axis stroke				
	150mm	250mm	350mm	450mm	550mm
	8.0	8.0	6.5	5.0	3.0

Note 2: Payload when a regeneration discharge unit (ABSU-2000) is used.

R: Right-handed

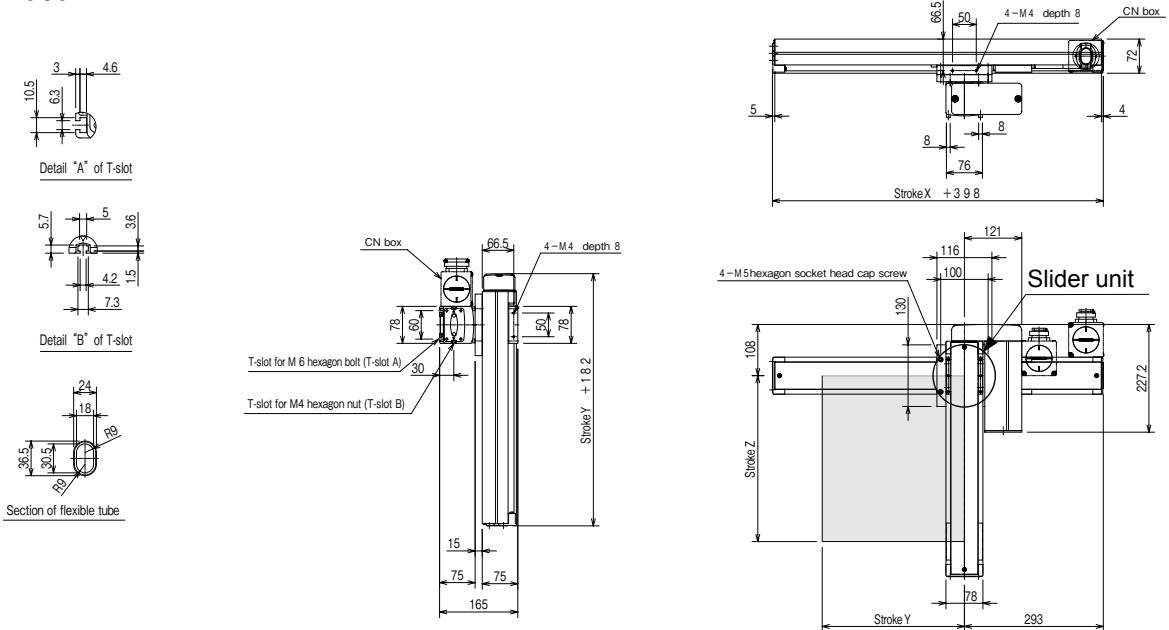

L: Left-handed

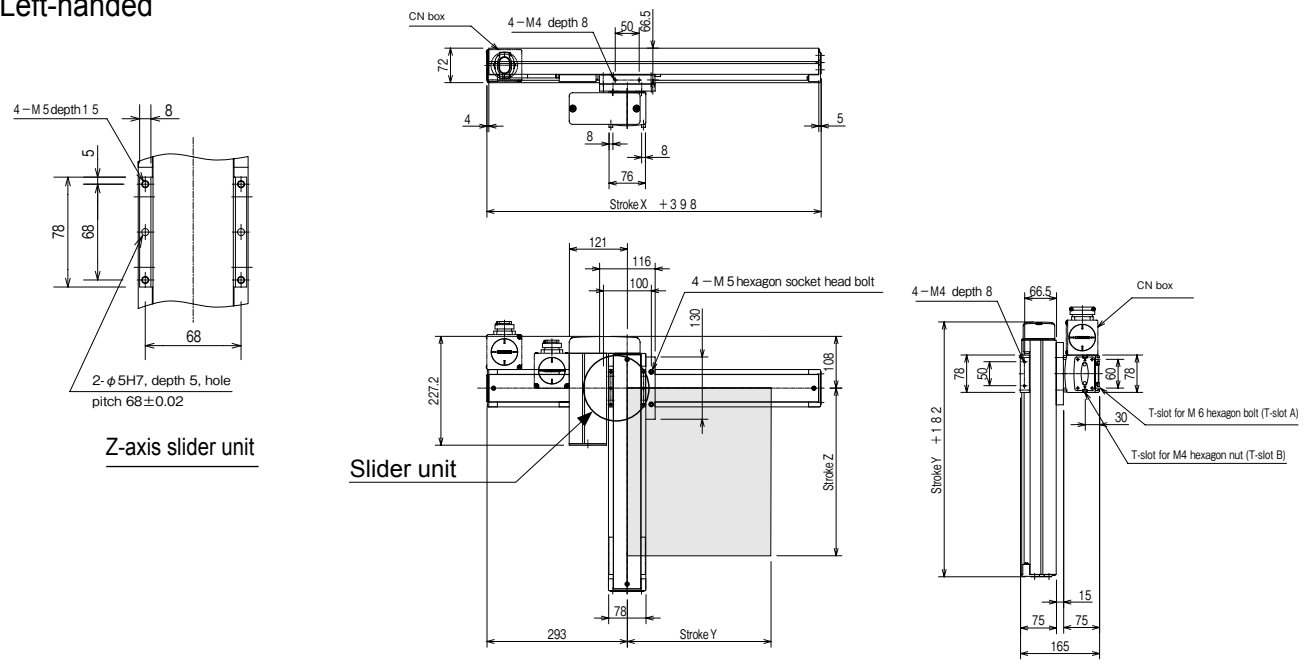

Y-Z Flexible-tube Spec.

# Orthogonal Axes Specifications

[Set designation]

**BA2 - A3 - H2AR C - 45 40 00 - OF 1 3**

Combined operation  
R: Right-handed  
L: Left-handed

Axis 1 stroke  
15 : 150mm  
95 : 950mm  
A5 : 1050mm

Axis 2 stroke  
10 : 100mm  
80 : 800mm

Controller  
0: None  
1: CA20-M10  
2: CA10-M00B  
3: CA10-M01B

Cable length  
3 : 3m 9 : 9m  
5 : 5m B : 11m  
7 : 7m D : 13m

Ball screw type

Y-axis: Ball screw driven  
Motor straight

Z-axis: Ball screw driven  
Motor straight

[Specifications]

	Y-axis	Z-axis
Type of axis	BB30E-ST-M20N-□ 5	BB10E-U □ -M10B-□ 0
Stroke (in increments of 100 mm)	150 ~ 1050mm	100 ~ 800mm
Maximum speed	1200mm/s (Note 1)	600mm/s (Note 1)
Positioning repeatability	±0.01mm	
Ball screw lead	20mm	10mm
Motor output	100W	100 W, with brake
Resolution	0.01mm	

Note 1: When the stroke is as given below, the maximum speed differs.

	Stroke (mm)	Maximum speed (mm/s)
Y-axis	750	1000
	850	800
	950 ~ 1050	600
Z-axis	700	500
	800	400

Acceleration/deceleration time when the maximum speed is set: 0.48 sec. or over

Maximum Payload (kg) (Note 2)	Z-axis stroke							
	100mm	200mm	300mm	400mm	500mm	600mm	700mm	800mm
	12.0	11.0	9.0	9.0	6.0	5.0	1.0	1.0

R: Right-handed

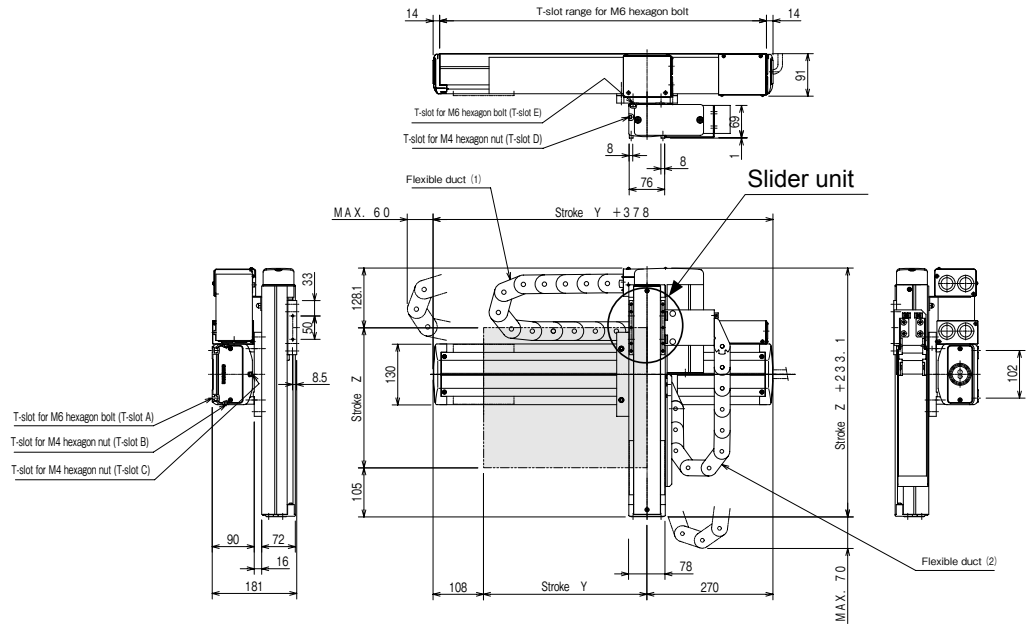
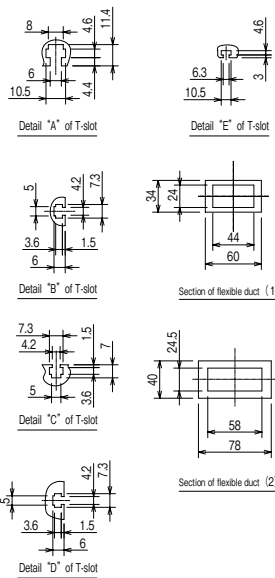

L: Left-handed

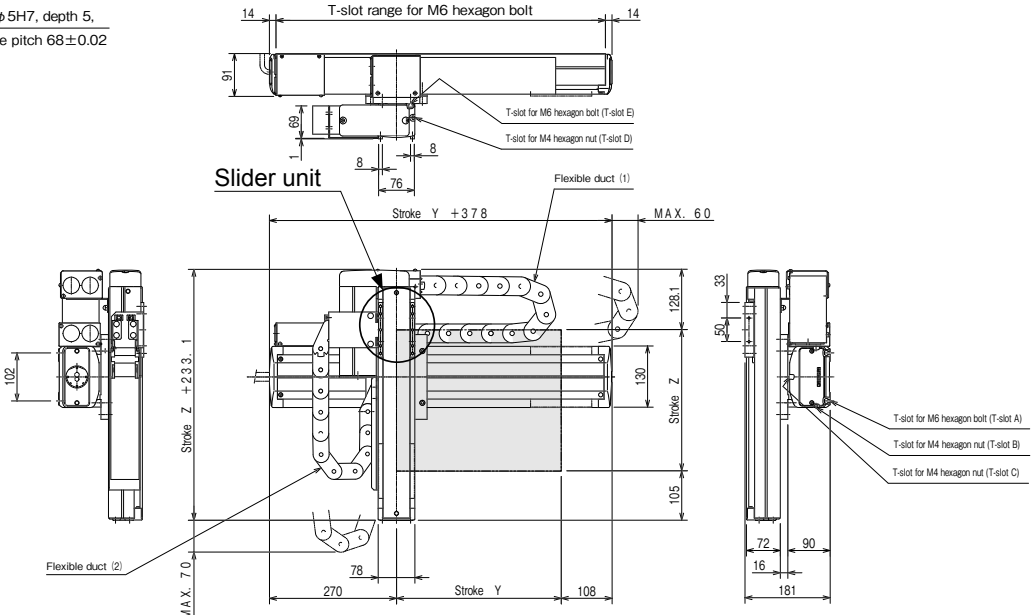
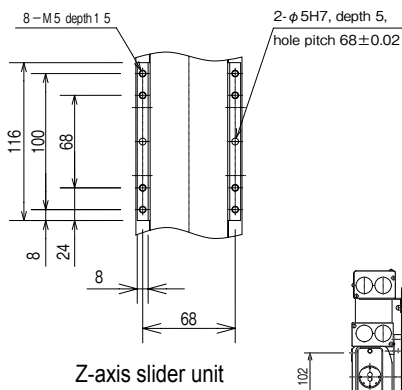

Y-Z Flexible-duct Spec.

[Set designation]

**BA2 – A3 – H2AR C – 45 40 00 – OT 1 3**

Combined operation  
R: Right-handed  
L: Left-handed

Axis 1 stroke  
15 : 150mm  
95 : 950mm  
A5 : 1050mm

Axis 2 stroke  
10 : 100mm  
80 : 800mm

Controller  
0: None  
1: CA20-M10  
2: CA10-M00B  
3: CA10-M01B

Cable length  
3 : 3m 9 : 9m  
5 : 5m B : 11m  
7 : 7m D : 13m

Ball screw type

Y-axis: Ball screw driven  
Motor straight

Z-axis: Ball screw driven  
Side mounted motor

[Specifications]

	Y-axis	Z-axis
Type of axis	BB30E-ST-M20N- □ 5	BB10E-U □ -M10B- □ 0
Stroke (in increments of 100 mm)	150 ~ 1050mm	100 ~ 800mm
Maximum speed	1200mm/s (Note 1)	600mm/s (Note 1)
Positioning repeatability	±0.01mm	
Ball screw lead	20mm	10mm
Motor output	100W	100 W, with brake
Resolution	0.01mm	

Acceleration/deceleration time when the maximum speed is set: 0.48 sec. or over

Note 1: When the stroke is as given below, the maximum speed differs.

	Stroke (mm)	Maximum speed (mm/s)
Y-axis	750	1000
	850	800
	950 ~ 1050	600
Z-axis	700	500
	800	400

Maximum Payload (kg) (Note 2)	Z-axis stroke							
	100mm	200mm	300mm	400mm	500mm	600mm	700mm	800mm
	12.0	11.0	9.0	9.0	6.0	5.0	1.0	1.0

Note 2: Payload when a regeneration discharge unit (ABSU-2000) is used.

R: Right-handed

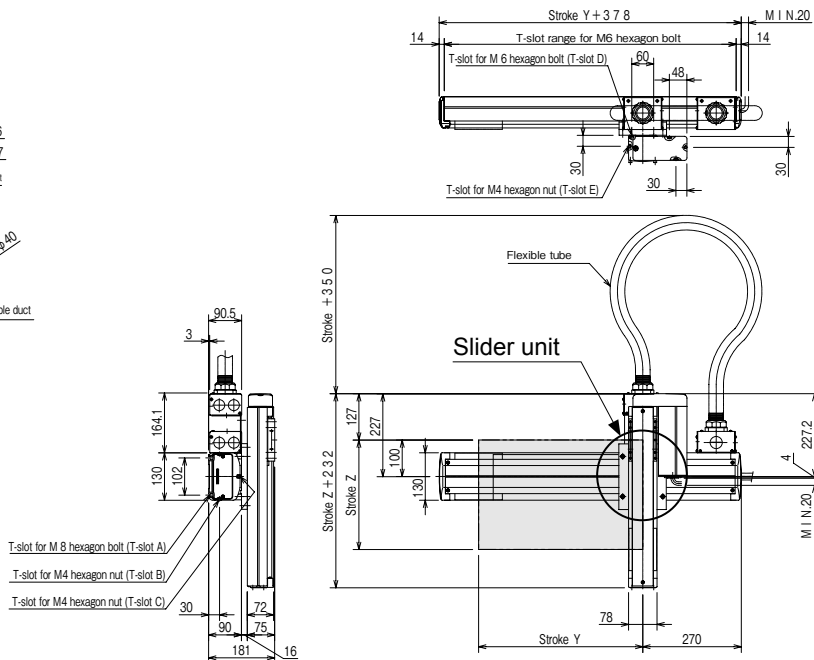
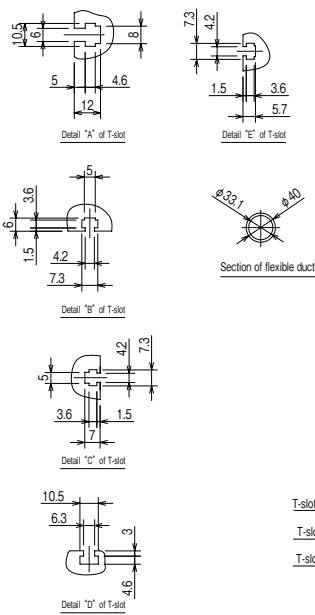

L: Left-handed

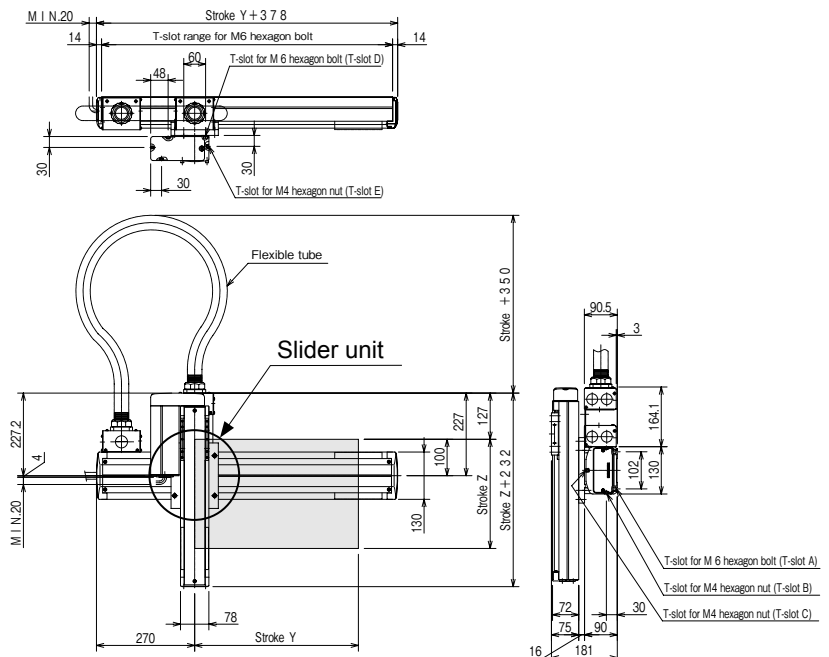
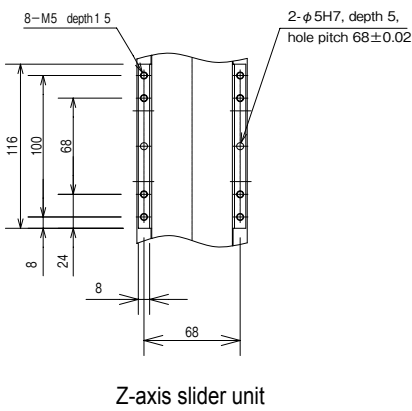



# Orthogonal Axes Specifications

[Set designation]

**BA2 – A3 – H2B R C – 40 40 00 – OF 1 3**

Combined operation R: Right-handed L: Left-handed	Axis 1 stroke 10 : 100mm 90 : 900mm A0 : 1000mm	Axis 2 stroke 10 : 100mm 90 : 900mm A0 : 1000mm	Controller 0: None 1: CA20-M10 2: CA10-M00B 3: CA10-M01B	Cable length 3 : 3m 5 : 5m 7 : 7m 9 : 9m B : 11m D : 13m
---	--	--	--	--

Ball screw type

- Y-axis: Ball screw driven  
Motor straight
- Z-axis: Ball screw driven  
Side mounted motor

[Specifications]

	Y-axis	Z-axis
Type of axis	BB30F-ST-M20N-□ 0	BB10E-U □ -M10B-□ 0
Stroke (in increments of 100 mm)	100 ~ 1000mm	100 ~ 1000mm
Maximum speed	1200mm/s (Note 1)	600mm/s (Note 1)
Positioning repeatability	±0.01mm	
Ball screw lead	20mm	10mm
Motor output	200W	100 W, with brake
Resolution	0.01mm	

Acceleration/deceleration time when the maximum speed is set: 0.36 sec. or over

Note 1: When the stroke is as given below, the maximum speed differs.

	Stroke (mm)	Maximum speed (mm/s)
Y-axis	700	1000
	800	800
	900 ~ 1000	600
Z-axis	700	500
	800	400
	900 ~ 1000	300

Maximum Payload (kg) (Note 2)	Z-axis stroke									
	100mm	200mm	300mm	400mm	500mm	600mm	700mm	800mm	900mm	1000mm
	12.0	12.0	12.0	12.0	12.0	12.0	10.0	5.0	4.0	4.0

Note 2: Payload when a regeneration discharge unit (ABSU-2000) is used.

R: Right-handed

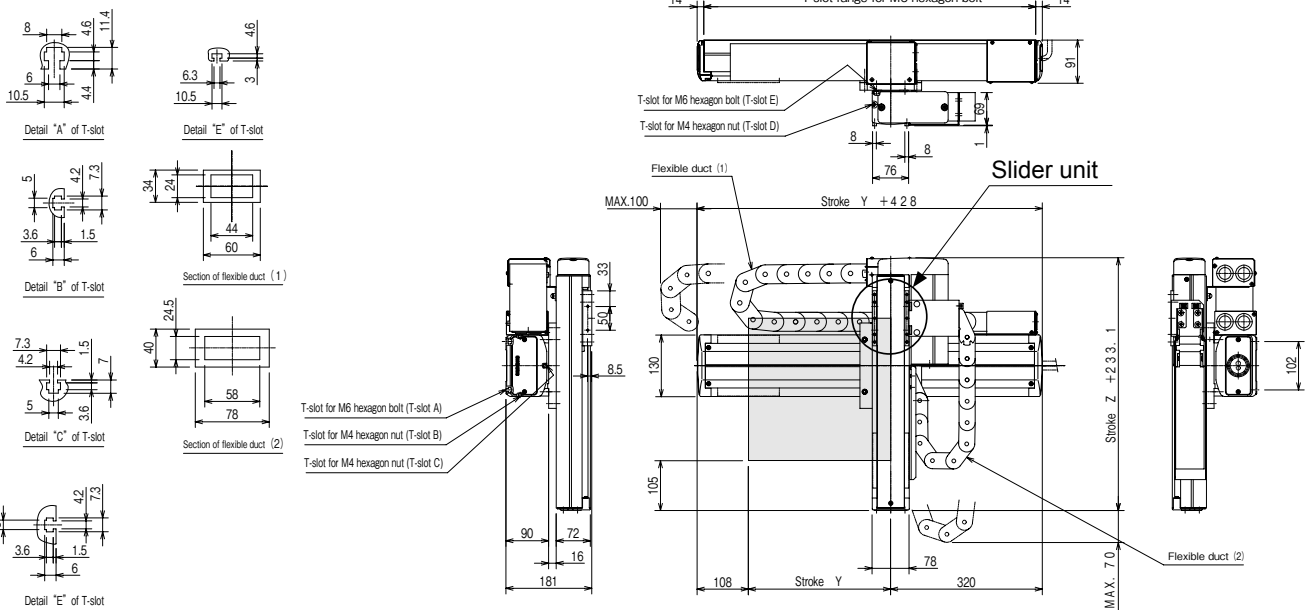

L: Left-handed

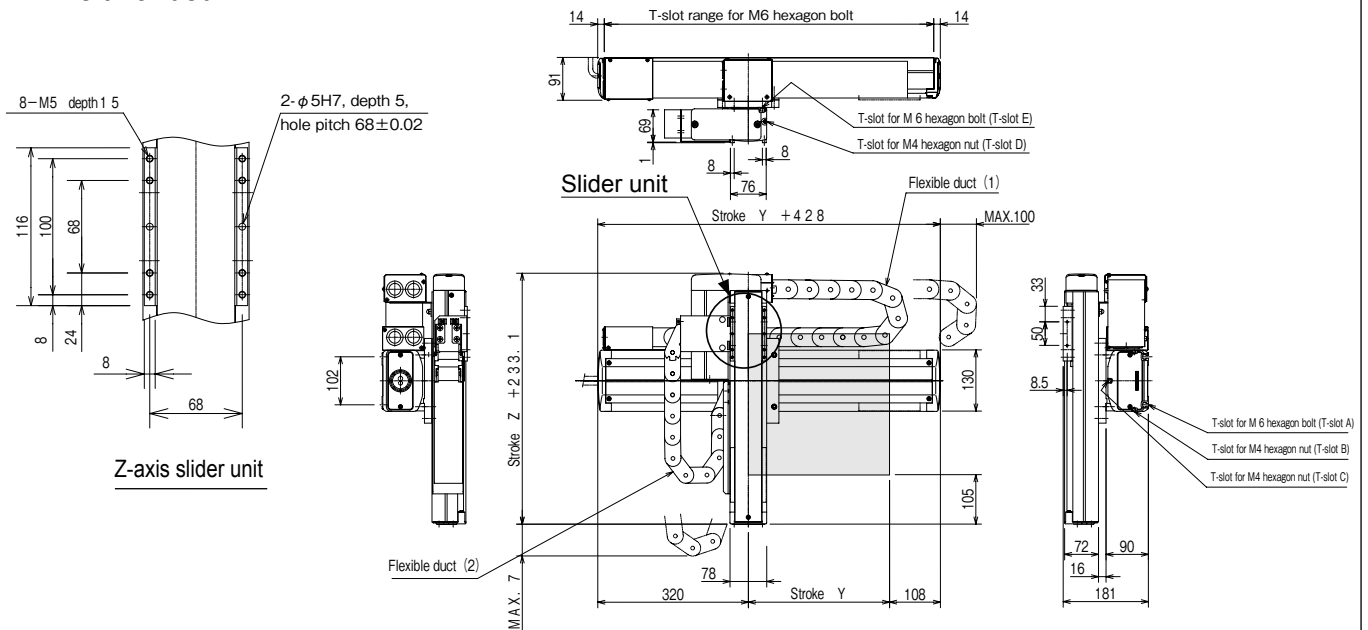

Y-Z Flexible-duct Spec.

[Set designation]

**BA2 – A3 – H2BR C – 40 40 00 – OT 1 3**

Combined operation  
R: Right-handed  
L: Left-handed

Axis 1 stroke  
10 : 100mm  
90 : 900mm  
A0 : 1000mm

Axis 2 stroke  
10 : 100mm  
90 : 900mm  
A0 : 1000mm

Controller  
0: None  
1: CA20-M10  
2: CA10-M00B  
3: CA10-M01B

Cable length  
3 : 3m 9 : 9m  
5 : 5m B : 11m  
7 : 7m D : 13m

Ball screw type

Y-axis: Ball screw driven  
Motor straight  
Z-axis: Ball screw driven  
Side mounted motor

[Specifications]

	Y-axis	Z-axis
Type of axis	BB30F-ST-M20N-□ 0	BB10E-U □ -M10B-□ 0
Stroke (in increments of 100 mm)	100 ~ 1000mm	100 ~ 1000mm
Maximum speed	1200mm/s (Note 1)	600mm/s (Note 1)
Positioning repeatability	±0.01mm	
Ball screw lead	20mm	10mm
Motor output	200W	100 W, with brake
Resolution	0.01mm	

Acceleration/deceleration time when the maximum speed is set: 0.36 sec. or over

Note 1: When the stroke is as given below, the maximum speed differs.

	Stroke (mm)	Maximum speed (mm/s)
Y-axis	700	1000
	800	800
	900 ~ 1000	600
Z-axis	700	500
	800	400
	900 ~ 1000	300

Maximum Payload (kg) (Note 2)	Z-axis stroke									
	100mm	200mm	300mm	400mm	500mm	600mm	700mm	800mm	900mm	1000mm
	12.0	12.0	12.0	12.0	12.0	12.0	10.0	5.0	4.0	4.0

Note 2: Payload when a regeneration discharge unit (ABSU-2000) is used.

R: Right-handed

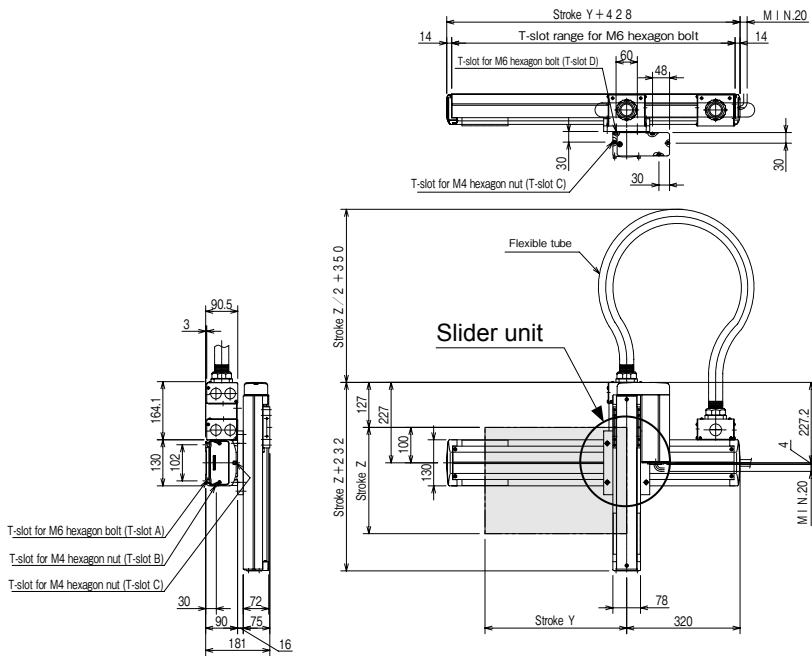
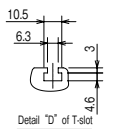
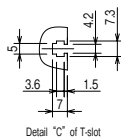
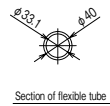
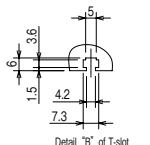
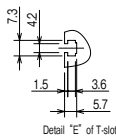
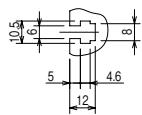

L: Left-handed

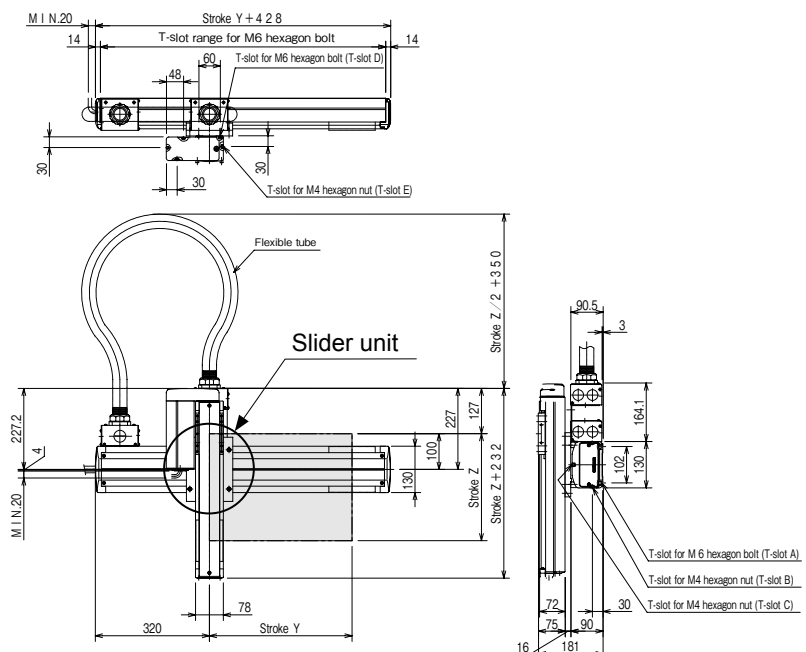
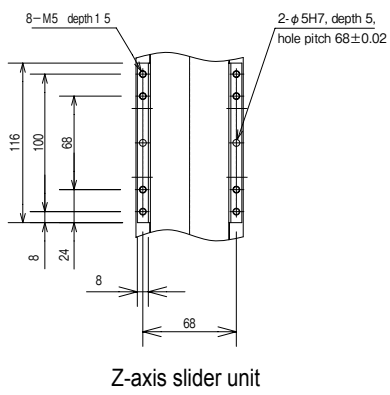

[Set designation]

**BA2 – A5 – H2A R C – 40 40 00 – OF 1 3**

Combined operation R: Right-handed L: Left-handed	Axis 1 stroke 20 : 200mm 90 : 900mm A0 : 1000mm F0 : 1500mm	Axis 2 stroke 10 : 100mm 90 : 900mm A0 : 1000mm	Controller 0: None 1: CA20-M10 2: CA10-M00B 3: CA10-M01B	Cable length 3 : 3m 5 : 5m 7 : 7m 9 : 9m B : 11m D : 13m
---	---	--	--	--

Ball screw type

- Y-axis: Ball screw driven  
Motor straight
- Z-axis: Ball screw driven  
Side mounted motor

Note 1: When the stroke is as given below, the maximum speed differs.

[Specifications]

	Y-axis	Z-axis
Type of axis	BB50F-ST-M20N-□ 0	BB30E-U □ -M10B-□ 0
Stroke (in increments of 100 mm)	200 ~ 1500mm	100 ~ 1000mm
Maximum speed	1200mm/s (Note 1)	600mm/s (Note 1)
Positioning repeatability	±0.01mm	
Ball screw lead	20mm	10mm
Motor output	200W	100 W, with brake
Resolution	0.01mm	

Acceleration/deceleration time when the maximum speed is set: 0.36 sec. or over

	Stroke (mm)	Maximum speed (mm/s)
Y-axis	700 ~ 800	1100
	900 ~ 1000	1000
	1100 ~ 1200	700
	1300	500
	1400	400
Z-axis	700	500
	800	400
	900 ~ 1000	300

Maximum Payload (kg) (Note 2)	Z-axis stroke									
	100mm	200mm	300mm	400mm	500mm	600mm	700mm	800mm	900mm	1000mm
	12.0	12.0	12.0	12.0	12.0	12.0	12.0	12.0	12.0	12.0

Note 2: Payload when a regeneration discharge unit (ABSU-2000) is used.

R: Right-handed

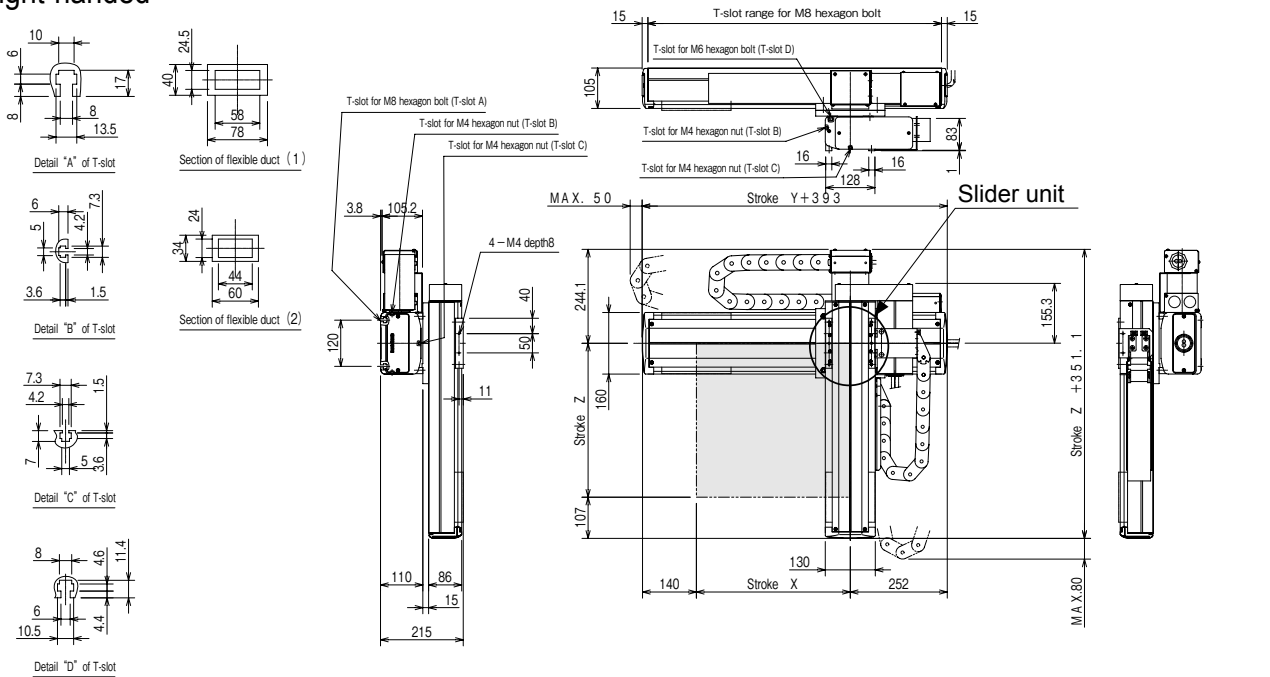

L: Left-handed

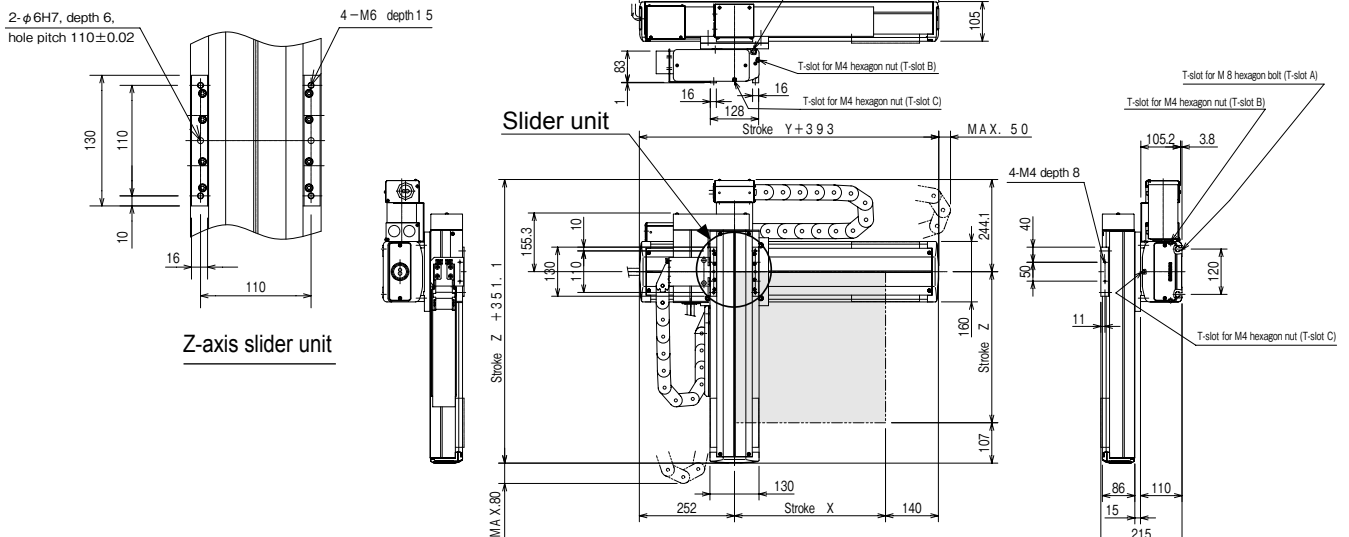

Y-Z Flexible-duct Spec.

[Set designation]

**BA2 - A5 - H2A R C - 40 40 00 - OT 1 3**

Combined operation R: Right-handed L: Left-handed	Axis 1 stroke 20 : 200mm 90 : 900mm A0 : 1000mm F0 : 1500mm	Axis 2 stroke 10 : 100mm 90 : 900mm A0 : 1000mm	Controller 0: None 1: CA20-M10 2: CA10-M00B 3: CA10-M01B	Cable length 3 : 3m 5 : 5m 7 : 7m 9 : 9m B : 11m D : 13m
---	---	--	--	--

Ball screw type

- Y-axis: Ball screw driven  
Motor straight
- Z-axis: Ball screw driven  
Side mounted motor

Note 1: When the stroke is as given below, the maximum speed differs.

	Stroke (mm)	Maximum speed (mm/s)
Y-axis	700 ~ 800	1100
	900 ~ 1000	1000
	1100 ~ 1200	700
	1300	500
	1400	400
Z-axis	1500	300
	700	500
	800	400
	900 ~ 1000	300

[Specifications]

	Y-axis	Z-axis
Type of axis	BB50F-ST-M20N-□ 0	BB30E-U □ -M10B-□ 0
Stroke (in increments of 100 mm)	200 ~ 1500mm	100 ~ 1000mm
Maximum speed	1200mm/s (Note 1)	600mm/s (Note 1)
Positioning repeatability	±0.01mm	
Ball screw lead	20mm	10mm
Motor output	200W	100W
Resolution	0.01mm	

Acceleration/deceleration time when the maximum speed is set: 0.36 sec. or over

Maximum Payload (kg) (Note 2)	Z-axis stroke									
	100mm	200mm	300mm	400mm	500mm	600mm	700mm	800mm	900mm	1000mm
	12.0	12.0	12.0	12.0	12.0	12.0	12.0	12.0	12.0	12.0

Note 2: Payload when a regeneration discharge unit (ABSU-2000) is used.

R: Right-handed

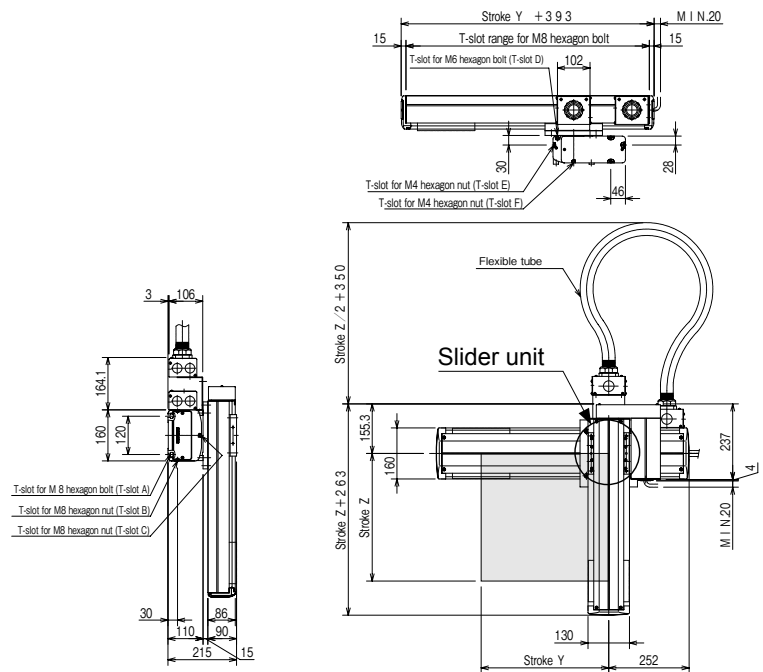
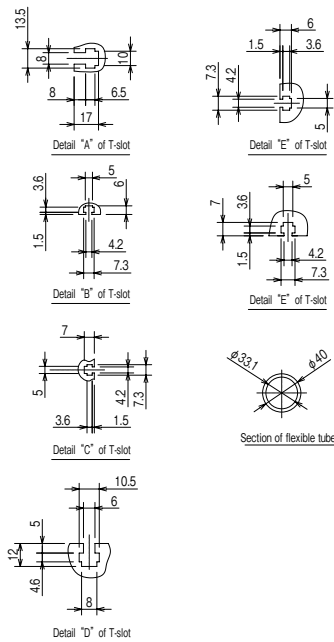

L: Left-handed

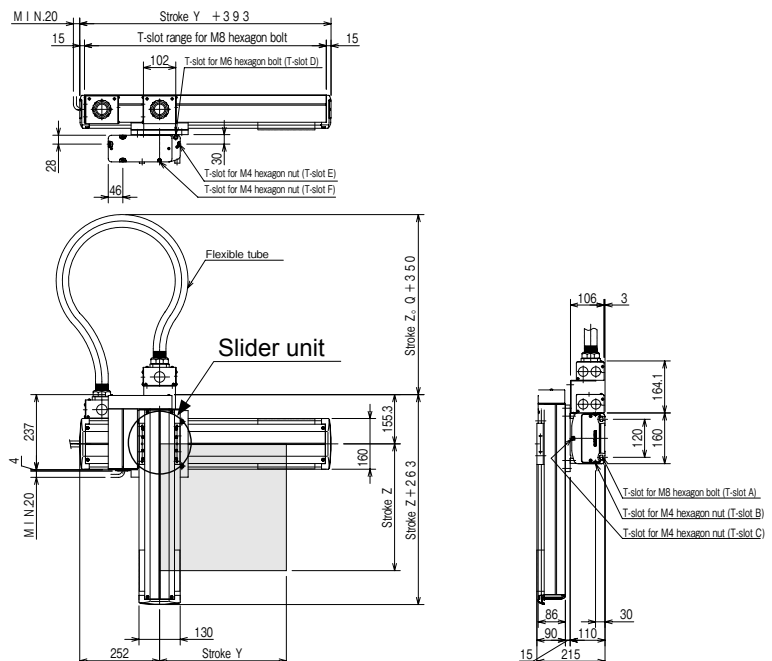
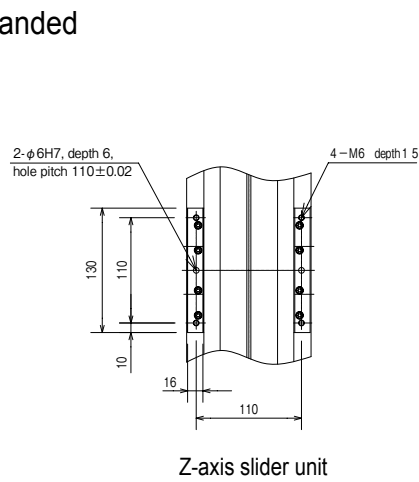

[Set designation]

**BA2 - A5 - H2B R C - 40 40 00 - OF 1 3**

Combined operation R: Right-handed L: Left-handed	Axis 1 stroke 20 : 200mm 90 : 900mm A0 : 1000mm F0 : 1500mm	Axis 2 stroke 10 : 100mm 90 : 900mm A0 : 1000mm	Controller 0: None 1: CA20-M10 2: CA10-M00B 3: CA10-M01B	Cable length 3 : 3m 5 : 5m 7 : 7m 9 : 9m B : 11m D : 13m
---	---	--	--	--

Ball screw type

- Y-axis: Ball screw driven  
Motor straight
- Z-axis: Ball screw driven  
Side mounted motor

Note 1: When the stroke is as given below, the maximum speed differs.

	Stroke (mm)	Maximum speed (mm/s)
Y-axis	700 ~ 800	1100
	900 ~ 1000	1000
	1100 ~ 1200	700
	1300	500
	1400	400
Z-axis	700	500
	800	400
	900 ~ 1000	300

[Specifications]

	Y-axis	Z-axis
Type of axis	BB50F-ST-M20N-□ 0	BB30F-U □ -M10B-□ 0
Stroke (in increments of 100 mm)	200 ~ 1500mm	100 ~ 1000mm
Maximum speed	1200mm/s (Note 1)	600mm/s (Note 1)
Positioning repeatability	±0.01mm	
Ball screw lead	20mm	10mm
Motor output	200W	200 W, with brake
Resolution	0.01mm	

Acceleration/deceleration time when the maximum speed is set: 0.36 sec. or over

Maximum Payload (kg) (Note 2)	Z-axis stroke									
	100mm	200mm	300mm	400mm	500mm	600mm	700mm	800mm	900mm	1000mm
	20.0	20.0	20.0	20.0	20.0	20.0	20.0	20.0	20.0	19.0

Note 2: Payload when a regeneration discharge unit (ABSU-2000) is used.

R: Right-handed

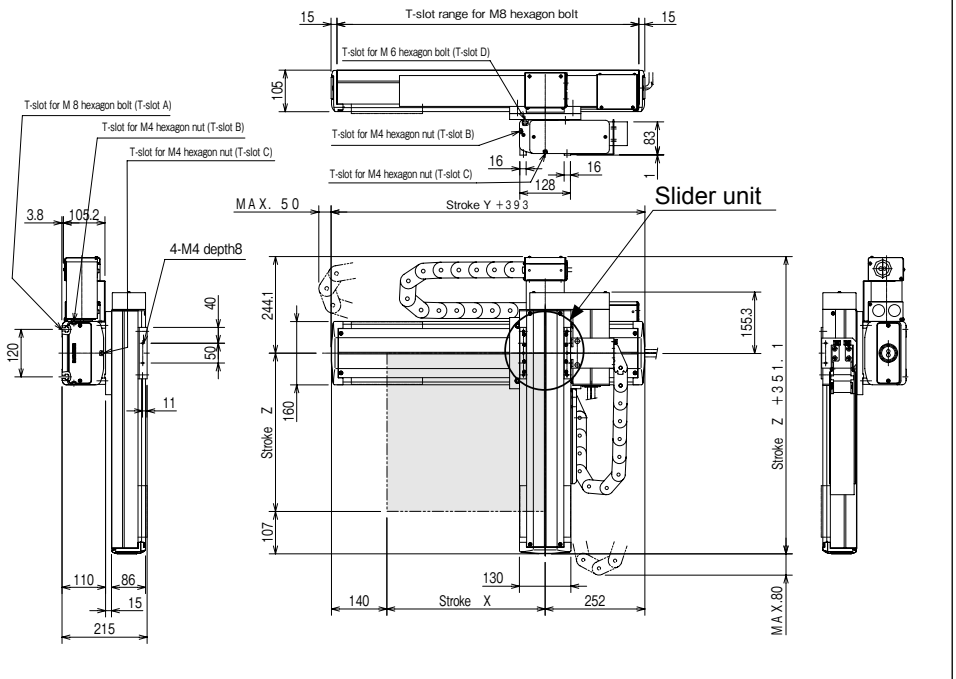
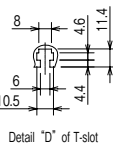
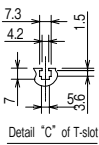
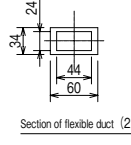
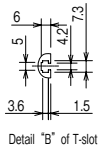
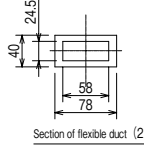
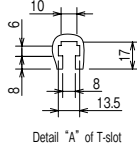

L: Left-handed

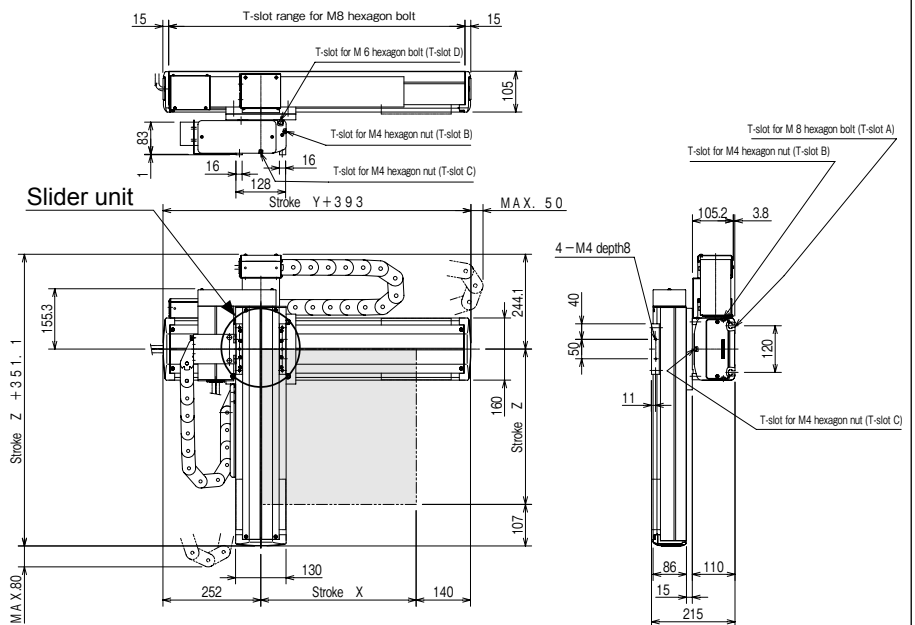
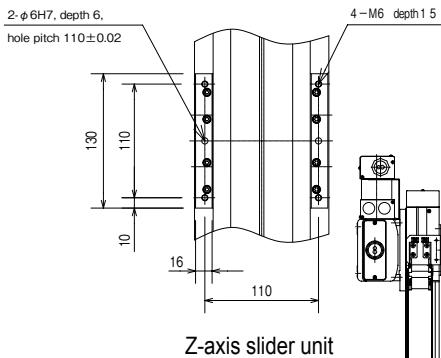

Y-Z Flexible-duct Spec.

[Set designation]

**BA2 – A5 – H2B R C – 40 40 00 – OT 1 3**

Combined operation R: Right-handed L: Left-handed	Axis 1 stroke 20 : 200mm 90 : 900mm A0 : 1000mm F0 : 1500mm	Axis 2 stroke 10 : 100mm 90 : 900mm A0 : 1000mm	Controller 0: None 1: CA20-M10 2: CA10-M00B 3: CA10-M01B	Cable length 3 : 3m 5 : 5m 7 : 7m 9 : 9m B : 11m D : 13m
---	---	--	--	--

Ball screw type

- Y-axis: Ball screw driven  
Motor straight
- Z-axis: Ball screw driven  
Side mounted motor

Note 1: When the stroke is as given below, the maximum speed differs.

	Stroke (mm)	Maximum speed (mm/s)
Y-axis	700 ~ 800	1100
	900 ~ 1000	1000
	1100 ~ 1200	700
	1300	500
	1400	400
Z-axis	1500	300
	700	500
	800 ~ 1000	400

[Specifications]

	Y-axis	Z-axis
Type of axis	BB50F-ST-M20N-□ 0	BB30F-U □ -M10B-□ 0
Stroke (in increments of 100 mm)	200 ~ 1500mm	100 ~ 1000mm
Maximum speed	1200mm/s (Note 1)	600mm/s (Note 1)
Positioning repeatability	±0.01mm	
Ball screw lead	20mm	10mm
Motor output	200W	200 W, with brake
Resolution	0.01mm	

Acceleration/deceleration time when the maximum speed is set: 0.36 sec. or over

Maximum Payload (kg) (Note 2)	Z-axis stroke									
	100mm	200mm	300mm	400mm	500mm	600mm	700mm	800mm	900mm	1000mm
	20.0	20.0	20.0	20.0	20.0	20.0	20.0	20.0	20.0	19.0

Note 2: Payload when a regeneration discharge unit (ABSU-2000) is used.

R: Right-handed

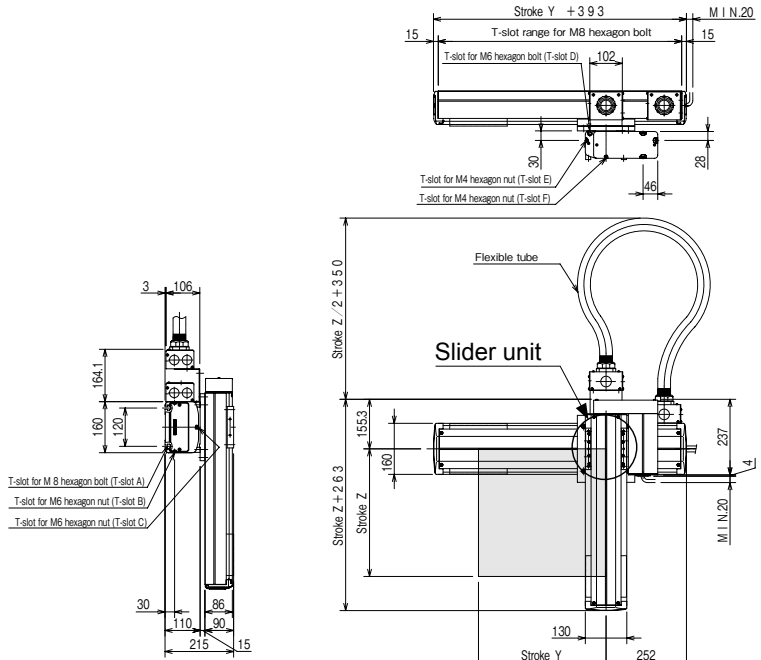
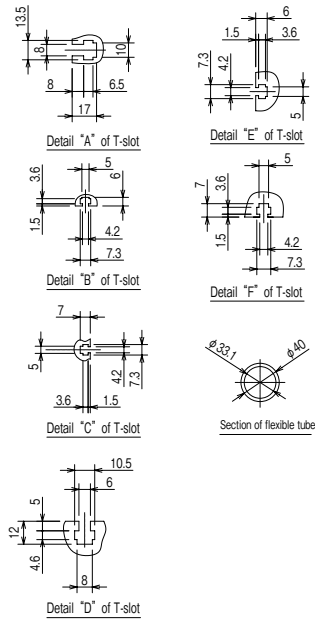

L: Left-handed

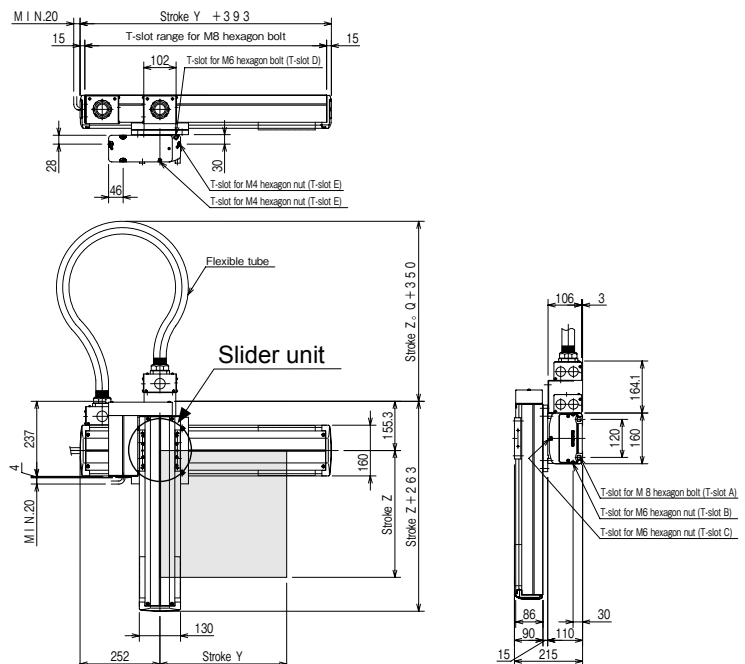
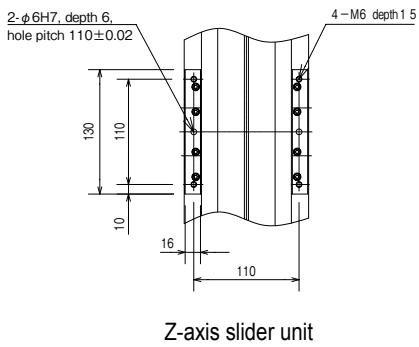

[Set designation]

BA2 - L1 - H2E R S - 40 45 00 - OF 1 3

Timing belt type

Y-axis: Timing belt driven  
Side mounted motor  
Z-axis: Ball screw driven  
Side mounted motor

Combined operation R: Right-handed L: Left-handed	Axis 1 stroke 15 : 150mm 95 : 950mm A5 : 1050mm H5 : 1750mm J5 : 1850mm	Axis 2 stroke 05 : 50mm 60 : 600mm	Controller 0: None 1: CA20-M10 2: CA10-M00B 3: CA10-M01B	Cable length 3 : 3m 9 : 9m 5 : 5m B : 11m 7 : 7m D : 13m
---	--	--	--	---

[Specifications]

	Y-axis	Z-axis
Type of axis	BB10E-B □ -S21N- □ 5	BB07D-ST-M12B- □ □
Stroke (in increments of 100 mm for Y-axis, 50mm for Z-axis)	150 ~ 1850mm	50 ~ 600mm
Maximum speed	1000mm/s	800mm/s (Note 1)
Positioning repeatability	±0.05mm	±0.02mm
Ball screw lead	21 mm (lead converted into ball screw)	12mm
Motor output	100W	50 W, with brake
Resolution	0.01mm	

Note 1: When the stroke is as given below, the maximum speed differs.

	Stroke (mm)	Maximum speed (mm/s)
Z-axis	450 ~ 500	600
	550 ~ 600	400

Acceleration/deceleration time when the maximum speed is set: 0.36 sec. or over

Maximum Payload (kg)	Z-axis stroke											
	50mm	100mm	150mm	200mm	250mm	300mm	350mm	400mm	450mm	500mm	550mm	600mm
	4.0	4.0	4.0	4.0	4.0	4.0	4.0	4.0	4.0	4.0	2.5	2.5

R: Right-handed

The values in parentheses are applicable when the X-axis stroke is 1,150 mm or over.

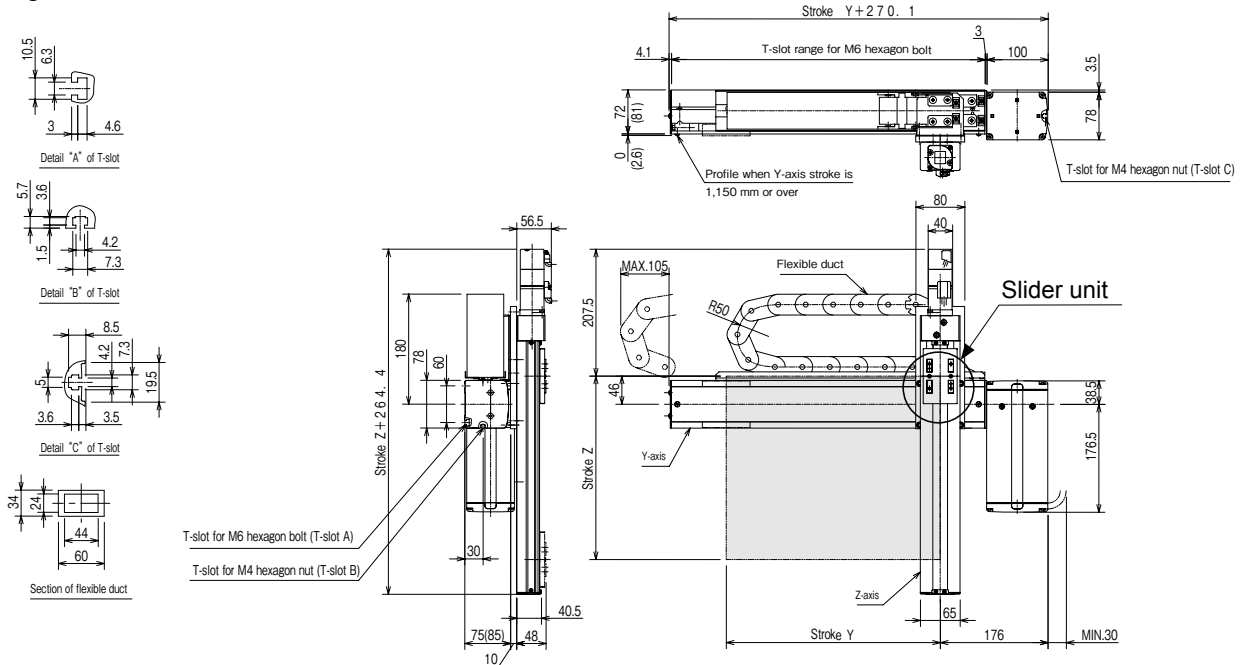

L: Left-handed

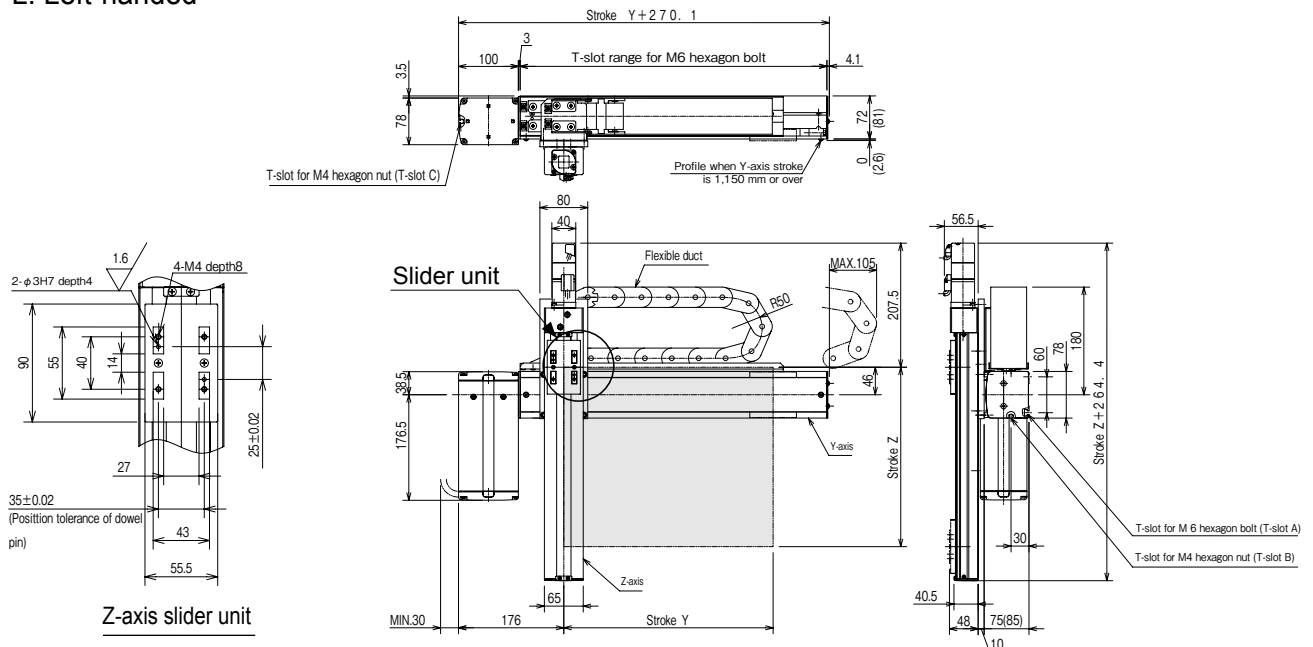

Y-Z Flexible-duct Spec.

[Set designation]

**BA2 - L1 - H2A R W - 40 45 00 - OF 1 3**

Timing belt type

Y-axis: Timing belt driven  
Side mouted motor

Z-axis: Ball screw driven  
Side mouted motor

組合わせ勝手

R : 右勝手  
L : 左勝手

Axis 1 stroke

10 : 100mm  
90 : 900mm  
A0 : 1000mm  
H0 : 1700mm  
J0 : 1800mm

Axis 2 stroke

15 : 150mm  
55 : 550mm

Controller

0: None  
1: CA20-M10  
2: CA10-M00B  
3: CA10-M01B

Cable length

3 : 3m 9 : 9m  
5 : 5m B : 11m  
7 : 7m D : 13m

[Specifications]

	Y-axis	Z-axis
Type of axis	BB10E-B □ -M21N- □ 0	BB10E-U □ -M10B- □ 5
Stroke (in increments of 100 mm)	100 ~ 1800mm	150 ~ 550mm
Maximum speed	1000mm/s	600mm/s
Positioning repeatability	±0.05mm	±0.01mm
Ball screw lead	21 mm (lead converted into ball screw)	10mm
Motor output	100W	100 W, with brake
Resolution	0.01mm	

Acceleration/deceleration time when the maximum speed is set: 0.48 sec. or over

Maximum Payload (kg)	Z-axis stroke				
	150mm	250mm	350mm	450mm	550mm
	8.0	8.0	6.0	5.0	3.0

R: Right-handed

The values in parentheses are applicable when the Y-axis stroke is 1,100 mm or over.

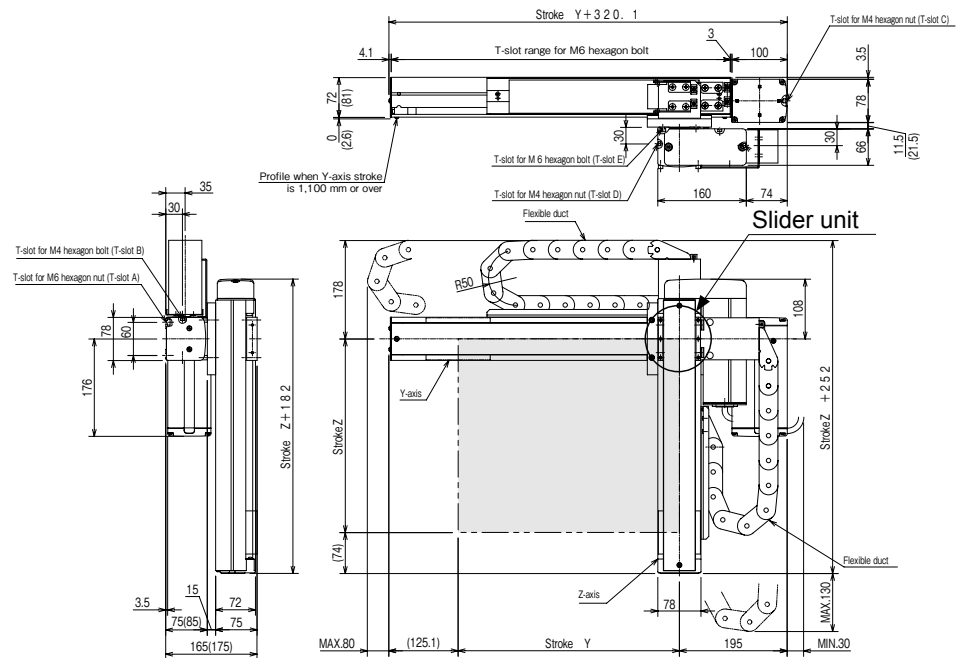
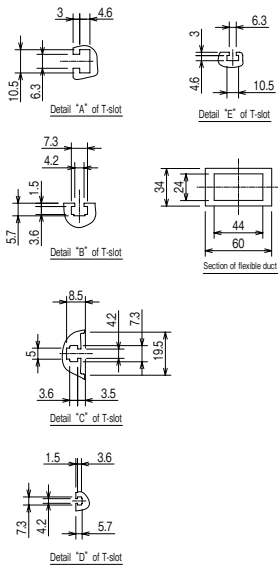

L: Left-handed

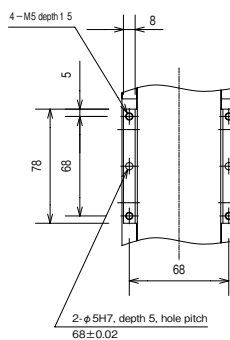

Z-axis slider unit

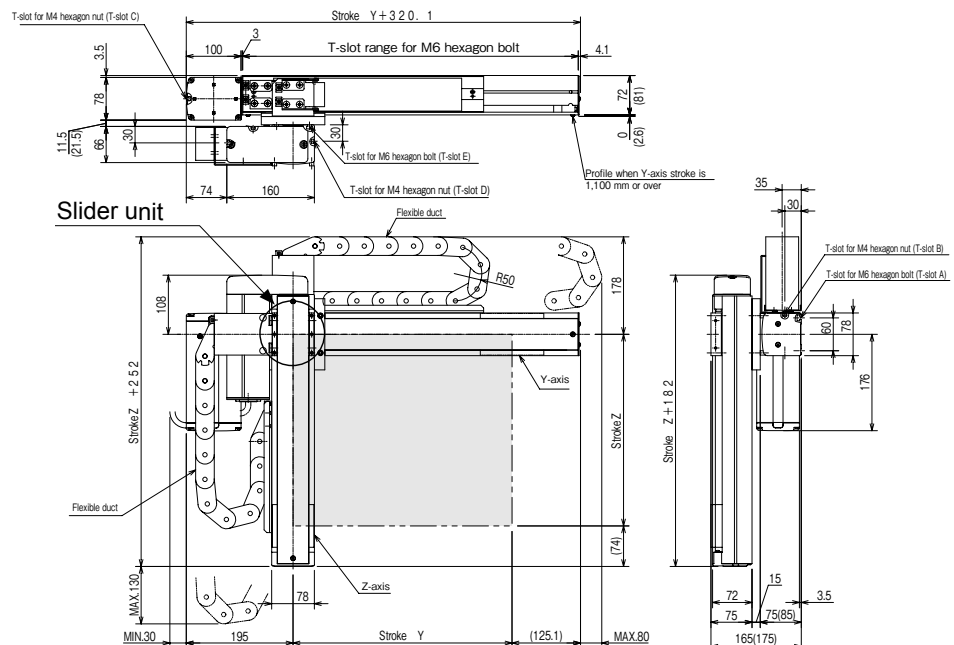



[Set designation]

**BA2 - L3 - H2A R W - 40 40 00 - OF 1 3**

Combined operation	Axis 1 stroke	Axis 2 stroke	Controller	Cable length
R: Right-handed	10 : 100mm JO : 1800mm	10 : 100mm	0: None	3 : 3m 9 : 9m
L: Left-handed	20 : 900mm NO : 2200mm A0 : 1000mm PO : 2300mm	80 : 800mm	1: CA20-M10 2: CA10-M00B 3: CA10-M01B	5 : 5m B : 11m 7 : 7m D : 13m
	HO : 1700mm RO : 2500mm			

Timing belt type

- Y-axis: Timing belt driven  
Side mounted motor
- Z-axis: Ball screw driven  
Motor straight

[Specifications]

	Y-axis	Z-axis
Type of axis	BB30E-B □ -M21N- □ 0	BB10E-U □ -M10B- □ 0
Stroke (in increments of 100 mm)	100 ~ 2500mm	100 ~ 800mm
Maximum speed	1000mm/s	600mm/s (Note 1)
Positioning repeatability	±0.05mm	±0.01mm
Ball screw lead	21 mm (lead converted into ball screw)	10mm
Motor output	100W	100 W, with brake
Resolution	0.01mm	

Note 1: When the stroke is as given below, the maximum speed differs.

	Stroke (mm)	Maximum speed (mm/s)
Z-axis	700	500
	800	400

Acceleration/deceleration time when the maximum speed is set: 0.48 sec. or over

Maximum Payload (kg)	Z-axis stroke							
	100mm	200mm	300mm	400mm	500mm	600mm	700mm	800mm
	6.0	6.0	5.0	4.0	4.0	3.0	1.0	1.0

R: Right-handed

The values in parentheses are applicable when the Y-axis stroke is 1,900 mm or over.

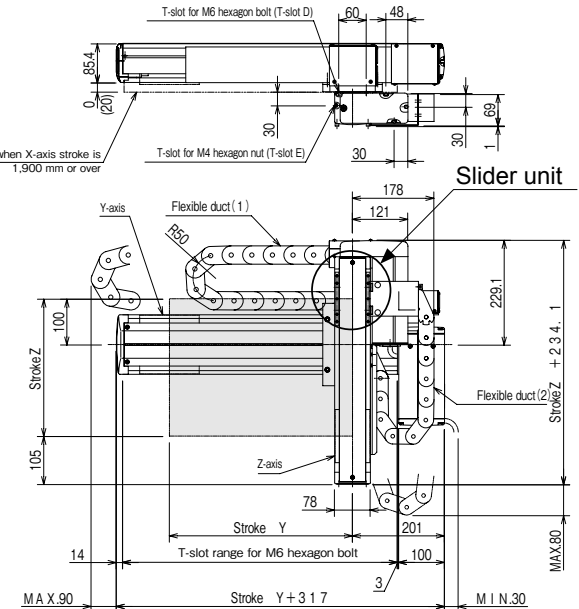
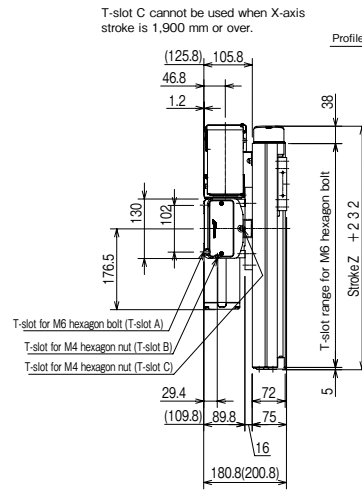
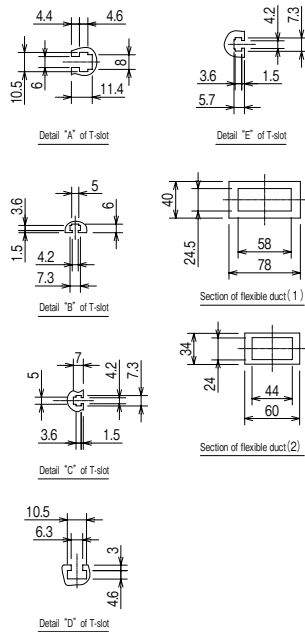

Y-Z Flexible-duct Spec.

L: Left-handed

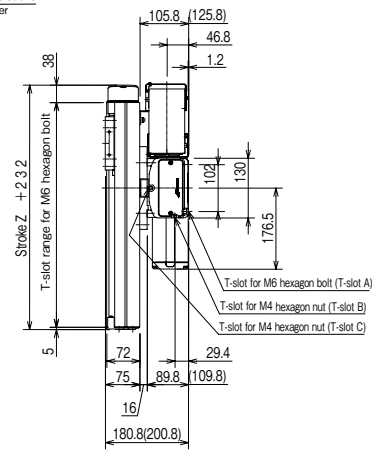
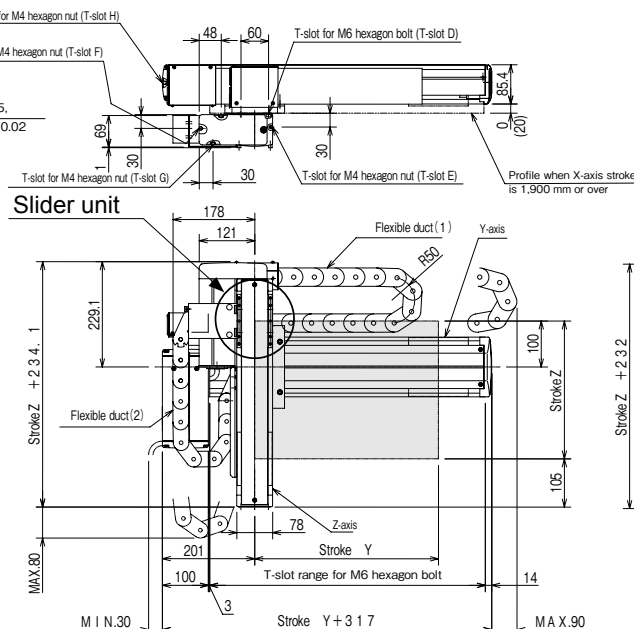
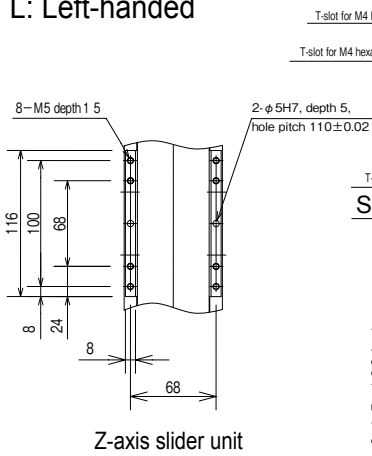

[Set designation]

**BA2 - L3 - H2B R W - 40 40 00 - OF 1 3**

Combined operation	Axis 1 stroke	Axis 2 stroke	Controller	Cable length
R: Right-handed L: Left-handed	10 : 100mm JO : 1800mm 2 : 90 : 900mm NO : 2200mm A0 : 1000mm PO : 2300mm 2 : H0 : 1700mm RO : 2500mm	10 : 100mm 2 : 90 : 900mm A0 : 1000mm	0: None 1: CA20-M10 2: CA10-M00B 3: CA10-M01B	3 : 3m 9 : 9m 5 : 5m B : 11m 7 : 7m D : 13m

Timing belt type

Y-axis: Timing belt driven  
Side mounted motor  
Z-axis: Ball screw driven  
Side mounted motor

[Specifications]

	Y-axis	Z-axis
Type of axis	BB30F-B □ -M21N- □ 0	BB10E-U □ -M10B- □ 0
Stroke (in increments of 100 mm)	100 ~ 2500mm	100 ~ 1000mm
Maximum speed	1000mm/s	600mm/s (Note 1)
Positioning repeatability	±0.05mm	±0.01mm
Ball screw lead	21 mm (lead converted into ball screw)	10mm
Motor output	200W	100 W, with brake
Resolution	0.01mm	

Note 1: When the stroke is as given below, the maximum speed differs.

	Stroke (mm)	Maximum speed (mm/s)
Z-axis	700	500
	800	400
	900 ~ 1000	300

Acceleration/deceleration time when the maximum speed is set: 0.36 sec. or over

Maximum Payload (kg) (Note 2)	Z-axis stroke									
	100mm	200mm	300mm	400mm	500mm	600mm	700mm	800mm	900mm	1000mm
	12.0	12.0	12.0	12.0	12.0	12.0	10.0	5.0	4.0	4.0

Note 2: Payload when a regeneration discharge unit (ABSU-2000) is used.

R: Right-handed

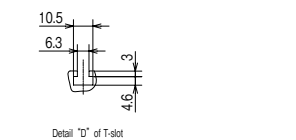
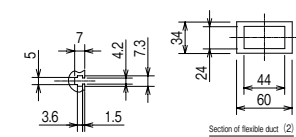
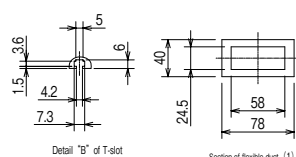
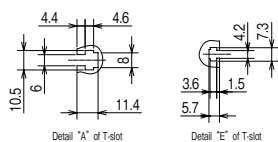

T-slot C cannot be used when X-axis stroke is 1,900 mm or over.

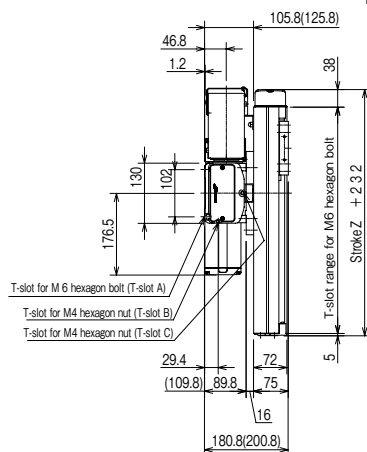

The values in parentheses are applicable when the Y-axis stroke is 1,900 mm or over.

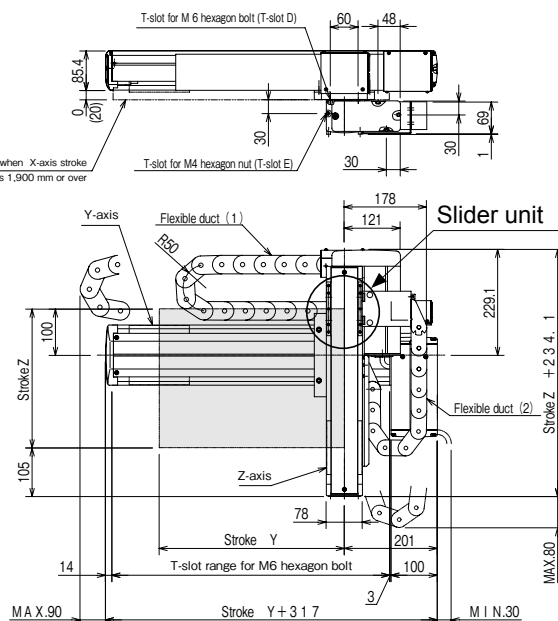

L: Left-handed

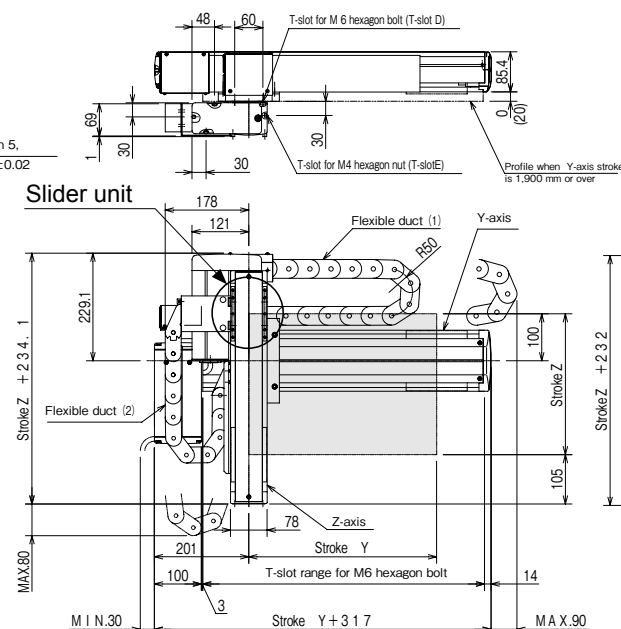
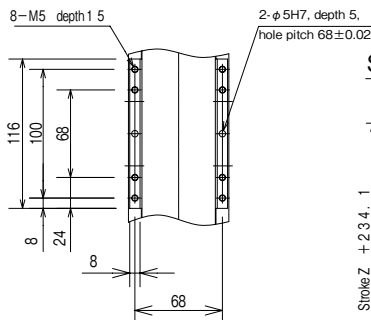

[Set designation]

**BA2 - L5 - H2A R W - 40 40 00 - OF 1 3**

Timing belt type

Y-axis: Timing belt driven  
Side mounted motor  
Z-axis: Ball screw driven  
Side mounted motor

Combined operation	Axis 1 stroke	Axis 2 stroke	Controller	Cable length
R: Right-handed	20 : 200mm J0 : 1800mm	10 : 100mm	0: None	3 : 3m 9 : 9m
L: Left-handed	90 : 900mm N0 : 2200mm	90 : 900mm	1: CA20-M10	5 : 5m B : 11m
	A0 : 1000mm P0 : 2300mm	A0 : 1000mm	2: CA10-M00B	7 : 7m D : 13m
	H0 : 1700mm R0 : 2500mm		3: CA10-M01B	

[Specifications]

	Y-axis	Z-axis
Type of axis	BB50F-B □ -M21N- □ 0	BB30E-U □ -M10B- □ 0
Stroke (in increments of 100 mm)	200 ~ 2500mm	100 ~ 1000mm
Maximum speed	1000mm/s	600mm/s (Note 1)
Positioning repeatability	±0.05mm	±0.01mm
Ball screw lead	21 mm (lead converted into ball screw)	10mm
Motor output	200W	100 W, with brake
Resolution	0.01mm	

Note 1: When the stroke is as given below, the maximum speed differs.

	Stroke (mm)	Maximum speed (mm/s)
Z-axis	700	500
	800	400
	900 ~ 1000	300

Acceleration/deceleration time when the maximum speed is set: 0.36 sec. or over

Maximum Payload (kg) (Note 2)	Z-axis stroke									
	100mm	200mm	300mm	400mm	500mm	600mm	700mm	800mm	900mm	1000mm
	12.0	12.0	12.0	12.0	12.0	12.0	12.0	12.0	12.0	12.0

Note 2: Payload when a regeneration discharge unit (ABSU-2000) is used.

R: Right-handed

The values in parentheses are applicable when the T-axis stroke is 1,900 mm or over.

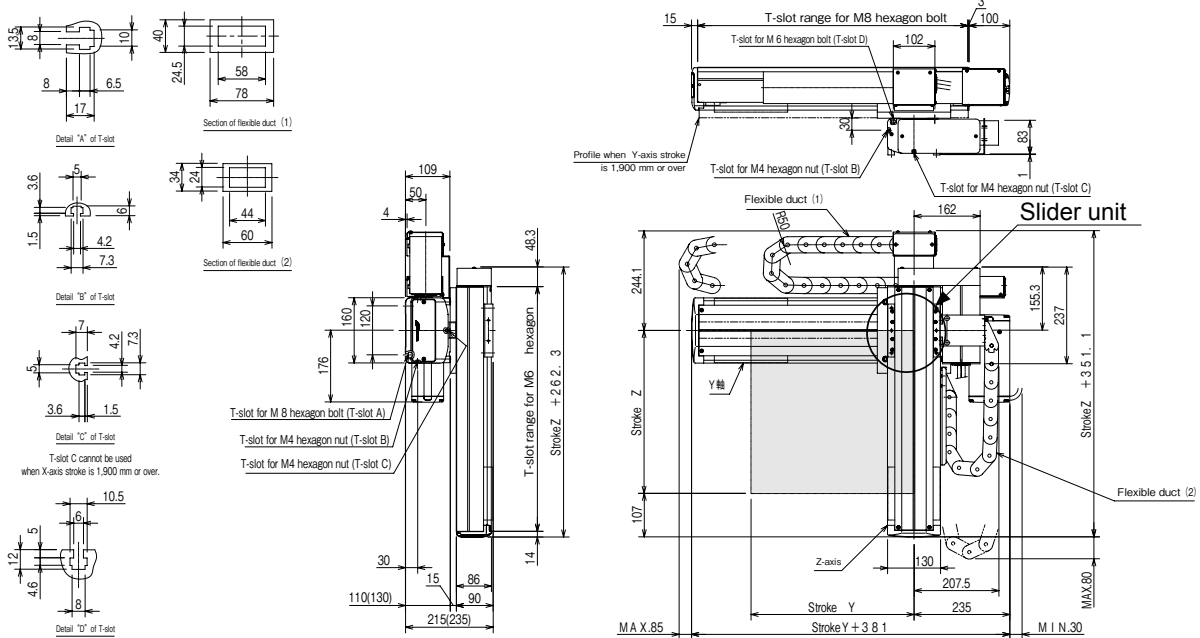

L: Left-handed

2-φ6H7, depth 6, hole pitch 110±0.02

4-M6 depth 1.5

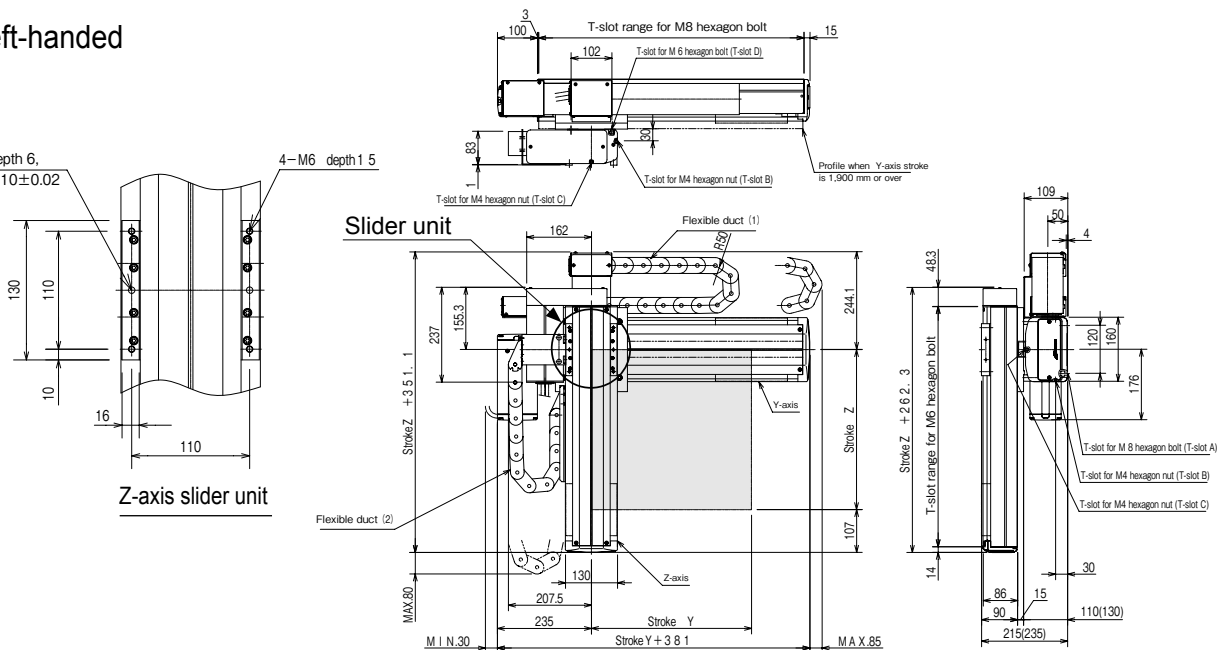

[Set designation]

**BA2 - L5 - H2B R W - 40 40 00 - OF 1 3**

Combined operation	Axis 1 stroke	Axis 2 stroke	Controller	Cable length
R: Right-handed	20 : 200mm JO : 1800mm	10 : 100mm	0: None	3 : 3m 9 : 9m
L: Left-handed	? : 900mm NO : 2200mm AO : 1000mm PO : 2300mm	? : 900mm AO : 1000mm	1: CA20-M10 2: CA10-M00B 3: CA10-M01B	5 : 5m B : 11m 7 : 7m D : 13m
	HO : 1700mm RO : 2500mm			

Timing belt type

Y-axis: Timing belt driven  
Side mouted motor  
Z-axis: Ball screw driven  
Side mouted motor

[Specifications]

	Y-axis	Z-axis
Type of axis	BB50F-B □ -M21N- □ 0	BB30F-U □ -M10B- □ 0
Stroke (in increments of 100 mm)	200 ~ 2500mm	100 ~ 1000mm
Maximum speed	1000mm/s	600mm/s (Note 1)
Positioning repeatability	±0.05mm	±0.01mm
Ball screw lead	21 mm (lead converted into ball screw)	10mm
Motor output	200W	200 W, with brake
Resolution	0.01mm	

Note 1: When the stroke is as given below, the maximum speed differs.

	Stroke (mm)	Maximum speed (mm/s)
Z-axis	700	500
	800	400
	900 ~ 1000	300

Acceleration/deceleration time when the maximum speed is set: 0.36 sec. or over

Maximum Payload (kg) (Note 2)	Z-axis stroke									
	100mm	200mm	300mm	400mm	500mm	600mm	700mm	800mm	900mm	1000mm
	20.0	20.0	20.0	20.0	20.0	20.0	19.0	17.0	16.0	15.0

Note 2: Payload when a regeneration discharge unit (ABSU-2000) is used.

R: Right-handed

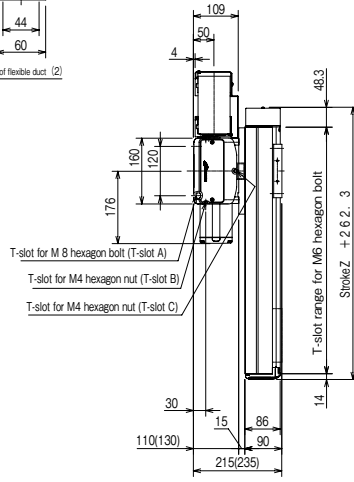
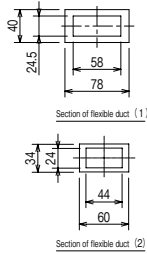
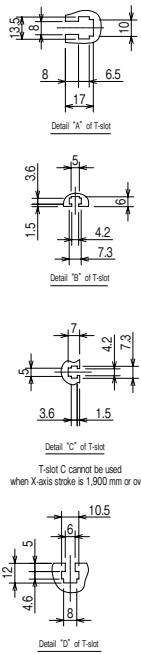

The values in parentheses are applicable when the X-axis stroke is 1,900 mm or over.

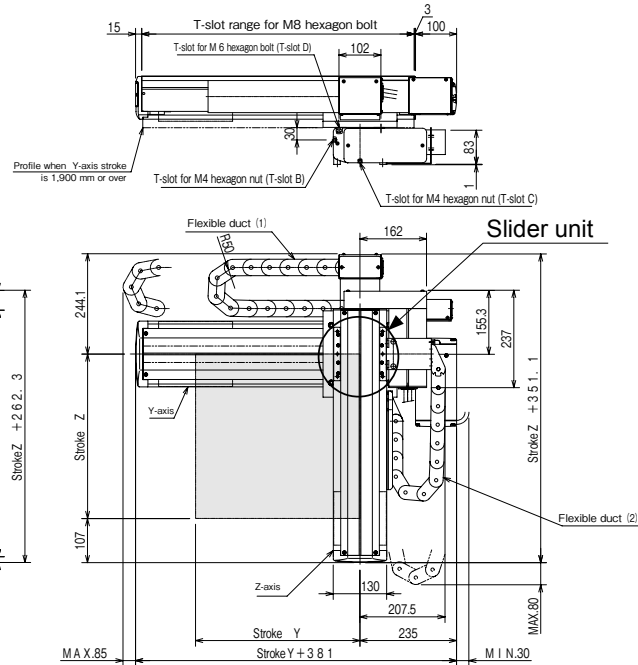

L: Left-handed

2-φ6H7, depth 6, hole pitch 110±0.02

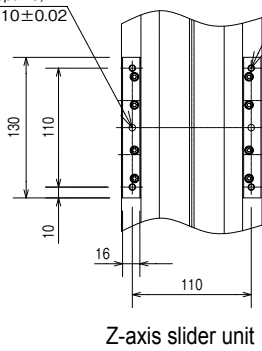

4-M6 depth 1 5

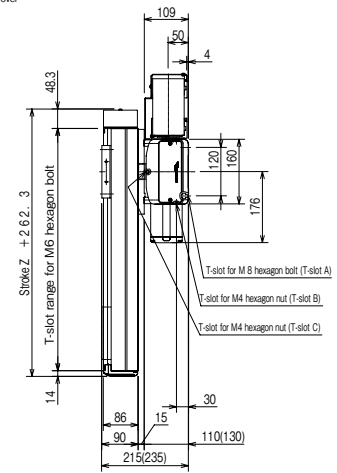
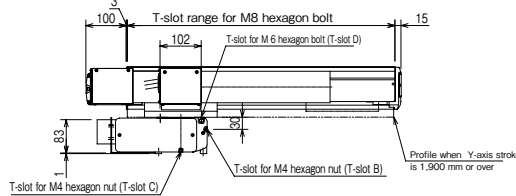
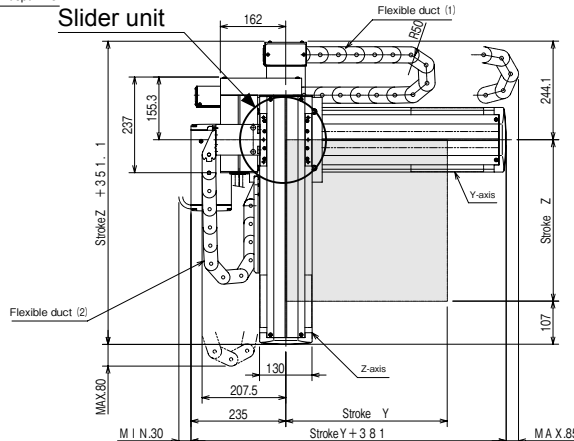

[Set designation]

BA2 – A1 – C2A RA – 40 45 00 – OF 1 3

Ball screw type

- Z-axis: Ball screw driven  
Motor straight
- Y-axis: Ball screw driven  
Motor straight

Combined operation R: Right-handed L: Left-handed	Axis 1 stroke 10 : 100mm 90 : 900mm A0 : 1000mm	Axis 2 stroke 15 : 150mm 65 : 650mm	Controller 0: None 1: CA20-M10 2: CA10-M00B 3: CA10-M01B	Cable length 3 : 3m 9 : 9m 5 : 5m B : 11m 7 : 7m D : 13m
---	--	---	--	---

[Specifications]

	Z-axis	Y-axis
Type of axis	BB10E-ST-M05B-□ 0	BB10E-ST-S20N-□ 5
Stroke (in increments of 100 mm)	100 ~ 1000mm	150 ~ 650mm
Maximum speed	300 mm/s (Note 1)	1200mm/s
Positioning repeatability	±0.01mm	
Ball screw lead	5mm	20mm
Motor output	100 W, with brake	100W
Resolution	0.01mm	

Note 1: When the stroke is as given below, the maximum speed differs.

	Stroke (mm)	Maximum speed (mm/s)
Z-axis	700	250
	800	200
	900 ~ 1000	150

Acceleration/deceleration time when the maximum speed is set: 0.36 sec. or over

Maximum Payload (kg) (Note 2)	Y-axis stroke					
	150mm	250mm	350mm	450mm	550mm	650mm
	15.0	12.0	9.0	6.5	5.0	3.5

Note 2: Payload when a regeneration discharge unit (ABSU-2000) is used.

R: Right-handed

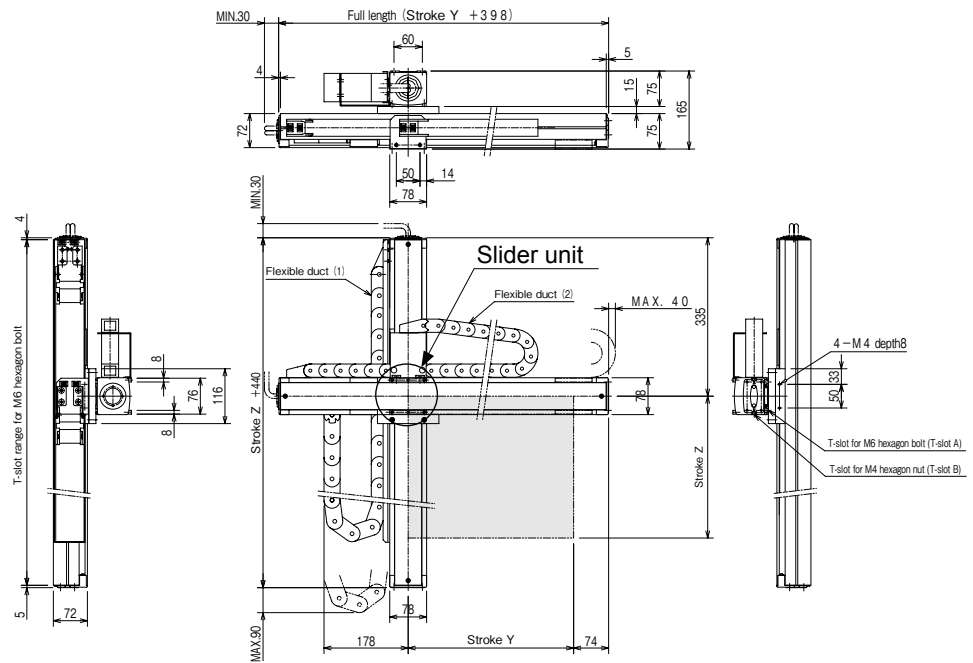
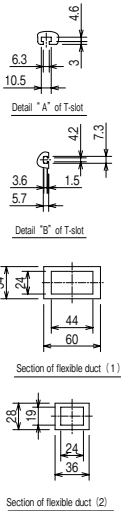

L: Left-handed

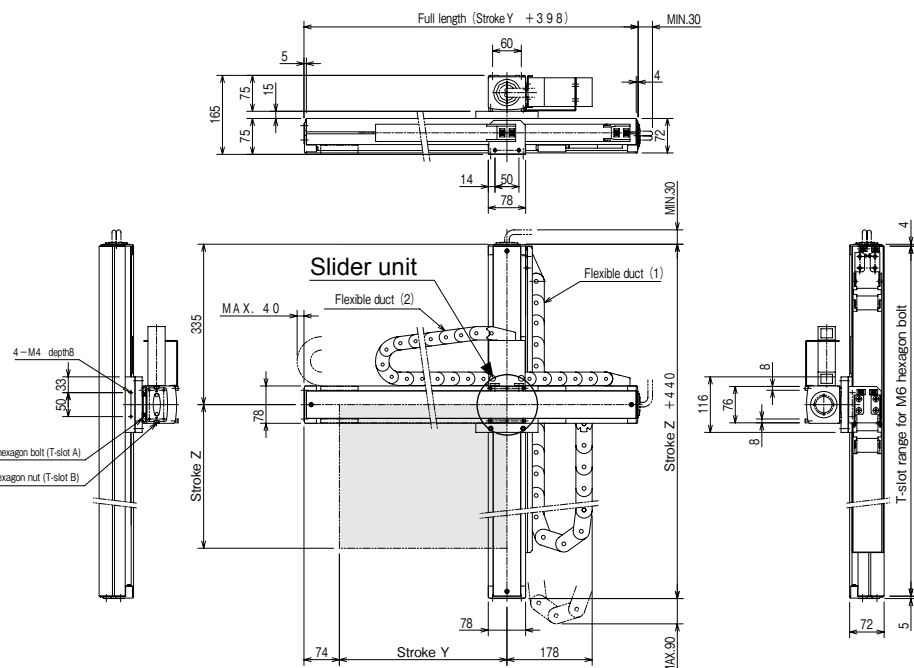
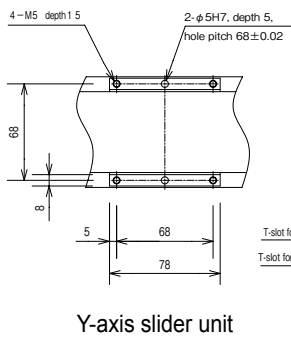

Z-Y Flexible-duct Spec.

[Set designation]

**BA2 – A1 – C2A RA – 40 45 00 – OT 1 3**

Combined operation	Axis 1 stroke	Axis 2 stroke	Controller	Cable length
R: Right-handed L: Left-handed	10 : 100mm 7 : 900mm A0 : 1000mm	15 : 150mm 65 : 650mm	0: None 1: CA20-M10 2: CA10-M00B 3: CA10-M01B	3 : 3m 9 : 9m 5 : 5m B : 11m 7 : 7m D : 13m

**Ball screw type**

Z-axis: Ball screw driven  
Motor straight  
Y-axis: Ball screw driven  
Motor straight

[Specifications]

	Z-axis	Y-axis
Type of axis	BB10E-ST-M05B-□ 0	BB10E-ST-S20N-□ 5
Stroke (in increments of 100 mm)	100 ~ 1000mm	150 ~ 650mm
Maximum speed	300 mm/s (Note 1)	1200mm/s
Positioning repeatability	±0.01mm	
Ball screw lead	5mm	20mm
Motor output	100 W, with brake	100W
Resolution	0.01mm	

Note 1: When the stroke is as given below, the maximum speed differs.

	Stroke (mm)	Maximum speed (mm/s)
Z-axis	700	250
	800	200
	900 ~ 1000	150

Acceleration/deceleration time when the maximum speed is set: 0.36 sec. or over

Maximum Payload (kg) (Note 2)	Y-axis stroke					
	150mm	250mm	350mm	450mm	550mm	650mm
	15.0	12.0	9.0	6.5	5.0	3.5

Note 2: Payload when a regeneration discharge unit (ABSU-2000) is used.

**R: Right-handed**

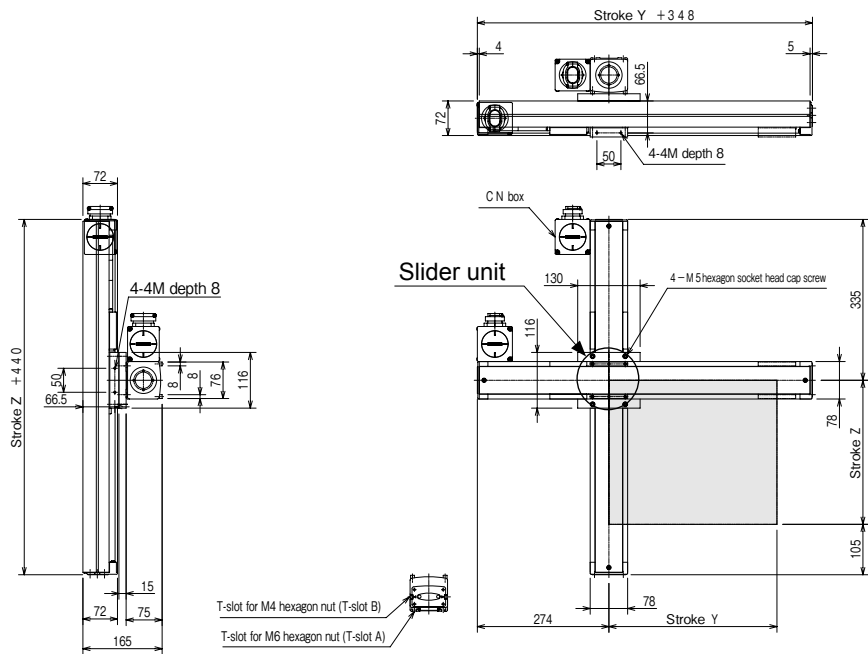
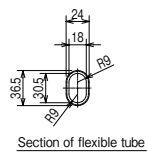
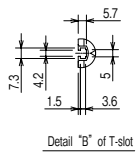
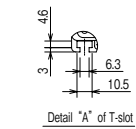

**L: Left-handed**

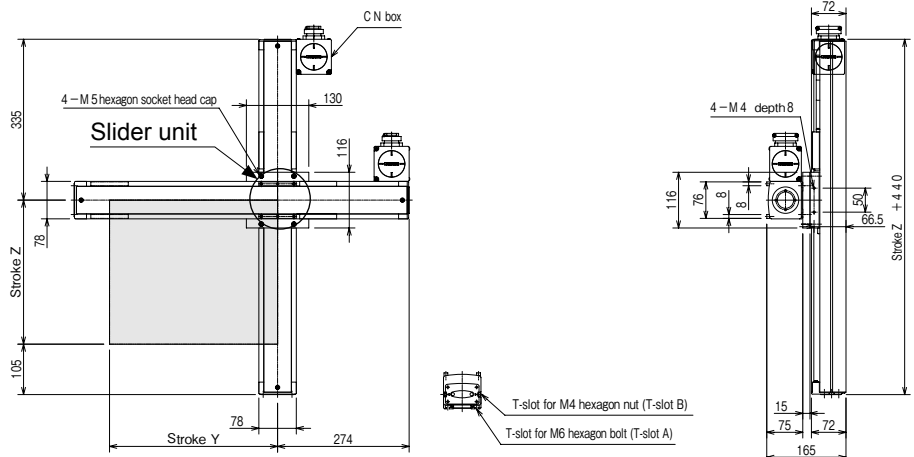
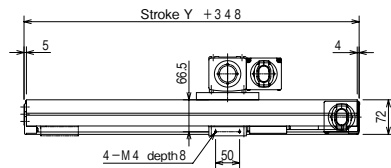
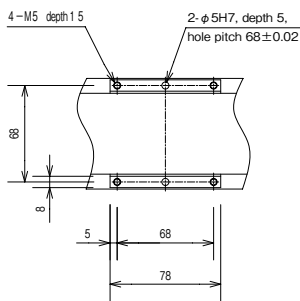

[Set designation]

**BA2 – A3 – C2A RA – 45 40 00 – OF 1 3**

Combined operation R: Right-handed L: Left-handed	Axis 1 stroke 15 : 150mm 95 : 950mm A5 : 1050mm	Axis 2 stroke 10 : 100mm 90 : 900mm	Controller 0: None 1: CA20-M10 2: CA10-M00B 3: CA10-M01B	Cable length 3 : 3m 9 : 9m 5 : 5m B : 11m 7 : 7m D : 13m
---	--	---	--	---

**Ball screw type**

Z-axis: Ball screw driven  
Motor straight  
Y-axis: Ball screw driven  
Motor straight

[Specifications]

	Z-axis	Y-axis
Type of axis	BB30E-ST-M05B-□ 5	BB10E-ST-M20N-□ 0
Stroke (in increments of 100 mm)	150 ~ 1050mm	100 ~ 900mm
Maximum speed	300 mm/s (Note 1)	1200mm/s (Note 1)
Positioning repeatability	±0.01mm	
Ball screw lead	5mm	20mm
Motor output	100 W, with brake	100W
Resolution	0.01mm	

Acceleration/deceleration time when the maximum speed is set: 0.36 sec. or over

Note 1: When the stroke is as given below, the maximum speed differs.

	Stroke (mm)	Maximum speed (mm/s)
Z-axis	750	250
	850	200
	950 ~ 1050	150
Y-axis	700	1000
	800	800
	900 ~ 1000	600

Maximum Payload (kg) (Note 2)	Y-axis stroke								
	100mm	200mm	300mm	400mm	500mm	600mm	700mm	800mm	900mm
	15.0	15.0	14.0	12.0	9.0	7.0	5.0	3.0	1.0

Note 2: Payload when a regeneration discharge unit (ABSU-2000) is used.

R: Right-handed

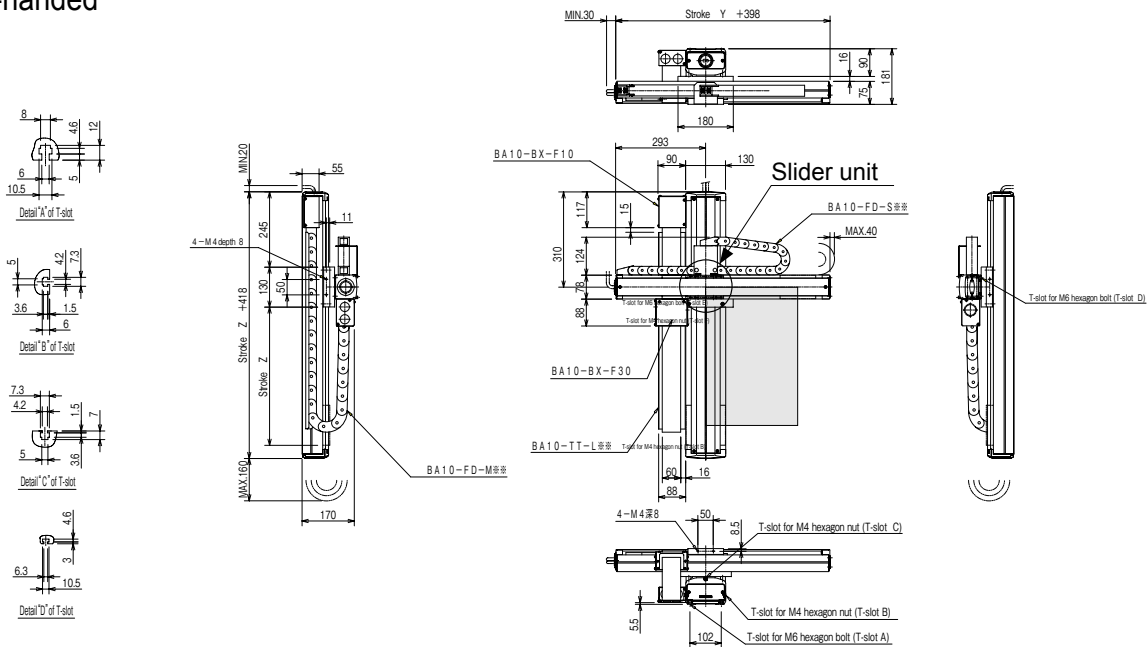

L: Left-handed

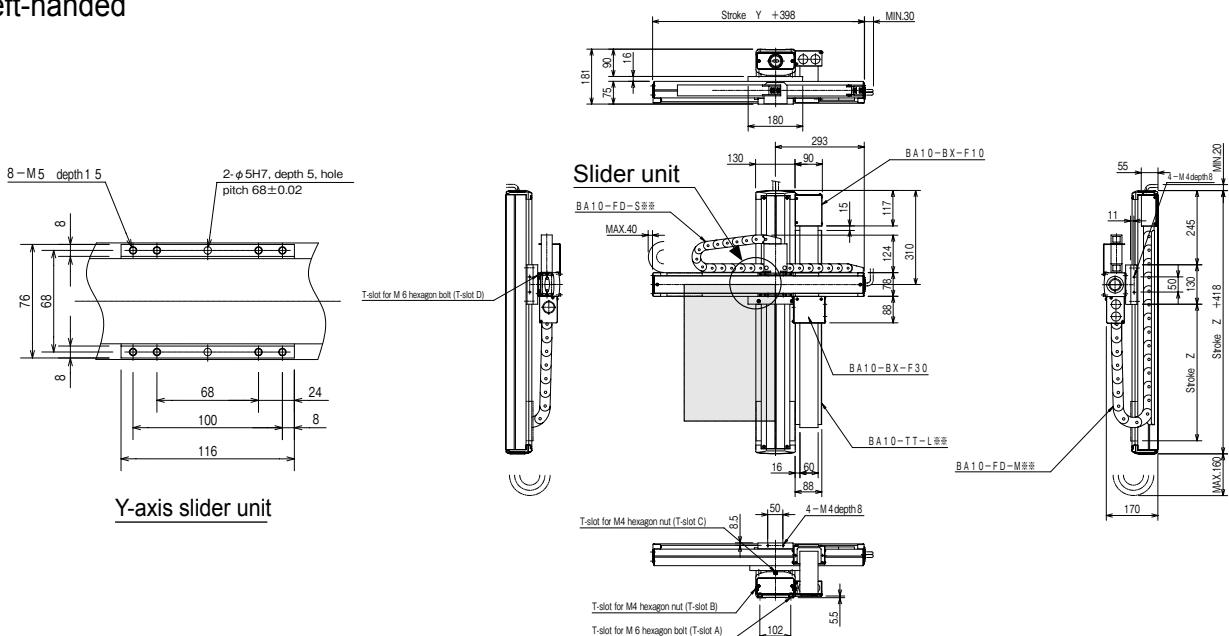

Z-Y Flexible-duct Spec.

[Set designation]

**BA2 – A3 – C2A RA – 45 40 00 – OT 1 3**

Combined operation	Axis 1 stroke	Axis 2 stroke	Controller	Cable length
R: Right-handed	15 : 150mm	10 : 100mm	0: None	3 : 3m 9 : 9m
L: Left-handed	95 : 950mm A5 : 1050mm	90 : 900mm	1: CA20-M10 2: CA10-M00B 3: CA10-M01B	5 : 5m B : 11m 7 : 7m D : 13m

**Ball screw type**

Z-axis: Ball screw driven  
Motor straight  
Y-axis: Ball screw driven  
Motor straight

[Specifications]

	Z-axis	Y-axis
Type of axis	BB30E-ST-M05B-□ 5	BB10E-ST-M20N-□ 0
Stroke (in increments of 100 mm)	150 ~ 1050mm	100 ~ 900mm
Maximum speed	300 mm/s (Note 1)	1200mm/s (Note 1)
Positioning repeatability	±0.01mm	
Ball screw lead	5mm	20mm
Motor output	100 W, with brake	100W
Resolution	0.01mm	

Acceleration/deceleration time when the maximum speed is set: 0.36 sec. or over

Note 1: When the stroke is as given below, the maximum speed differs.

	Stroke (mm)	Maximum speed (mm/s)
Z-axis	750	250
	850	200
	950 ~ 1050	150
Y-axis	700	1000
	800	800
	900 ~ 1000	600

Maximum Payload (kg) (Note 2)	Y-axis stroke								
	100mm	200mm	300mm	400mm	500mm	600mm	700mm	800mm	900mm
	15.0	15.0	14.0	12.0	9.0	7.0	5.0	3.0	1.0

Note 2: Payload when a regeneration discharge unit (ABSU-2000) is used.

**R: Right-handed**

Note 1: The height of the flexible tube is an approximate value.

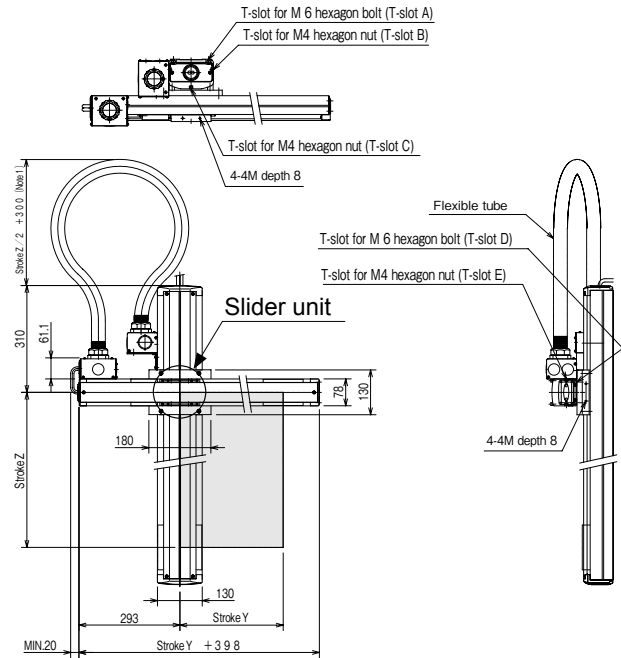
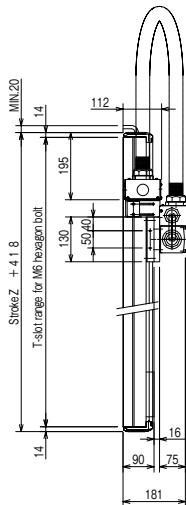
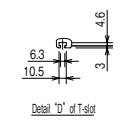
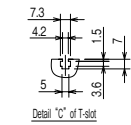
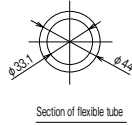
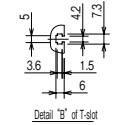
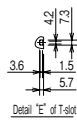
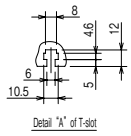

**L: Left-handed**

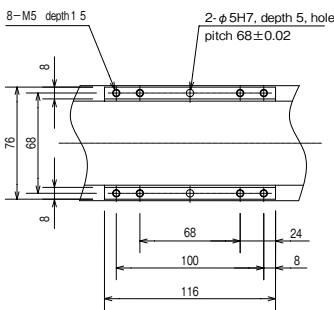

Y-axis slider unit

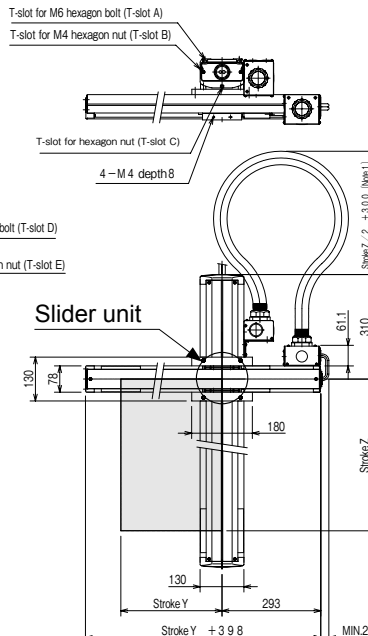
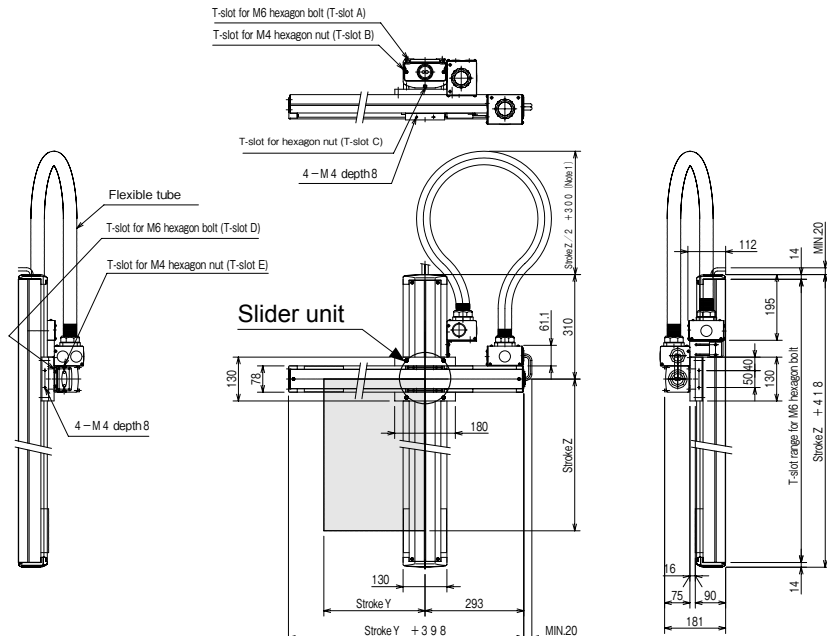



[Set designation]

**BA2 – A3 – C2B RA – 40 40 00 – OF 1 3**

Combined operation	Axis 1 stroke	Axis 2 stroke	Controller	Cable length
R: Right-handed L: Left-handed	10 : 100mm 90 : 900mm A0 : 1000mm	10 : 100mm 90 : 900mm	0: None 1: CA20-M10 2: CA10-M00B 3: CA10-M01B	3 : 3m 9 : 9m 5 : 5m B : 11m 7 : 7m D : 13m

**Ball screw type**

Z-axis: Ball screw driven  
Motor straight  
Y-axis: Ball screw driven  
Motor straight

[Specifications]

	Z-axis	Y-axis
Type of axis	BB30F-ST-M05B-□ 0	BB10E-ST-M20N-□ 0
Stroke (in increments of 100 mm)	100 ~ 1000mm	100 ~ 900mm
Maximum speed	300 mm/s (Note 1)	1200 mm/s (Note 1)
Positioning repeatability	±0.01mm	
Ball screw lead	5mm	20mm
Motor output	200W, with brake	100W
Resolution	0.01mm	

Acceleration/deceleration time when the maximum speed is set: 0.36 sec. or over

Note 1: When the stroke is as given below, the maximum speed differs.

	Stroke (mm)	Maximum speed (mm/s)
Z-axis	700	250
	800	200
	900 ~ 1000	150
Y-axis	700	1000
	800	800
	900 ~ 1000	600

Maximum Payload (kg) (Note 2)	Y-axis stroke								
	100mm	200mm	300mm	400mm	500mm	600mm	700mm	800mm	900mm
	15.0	15.0	15.0	12.0	9.0	7.0	5.0	3.0	1.0

Note 2: Payload when a regeneration discharge unit (ABSU-2000) is used.

**R: Right-handed**

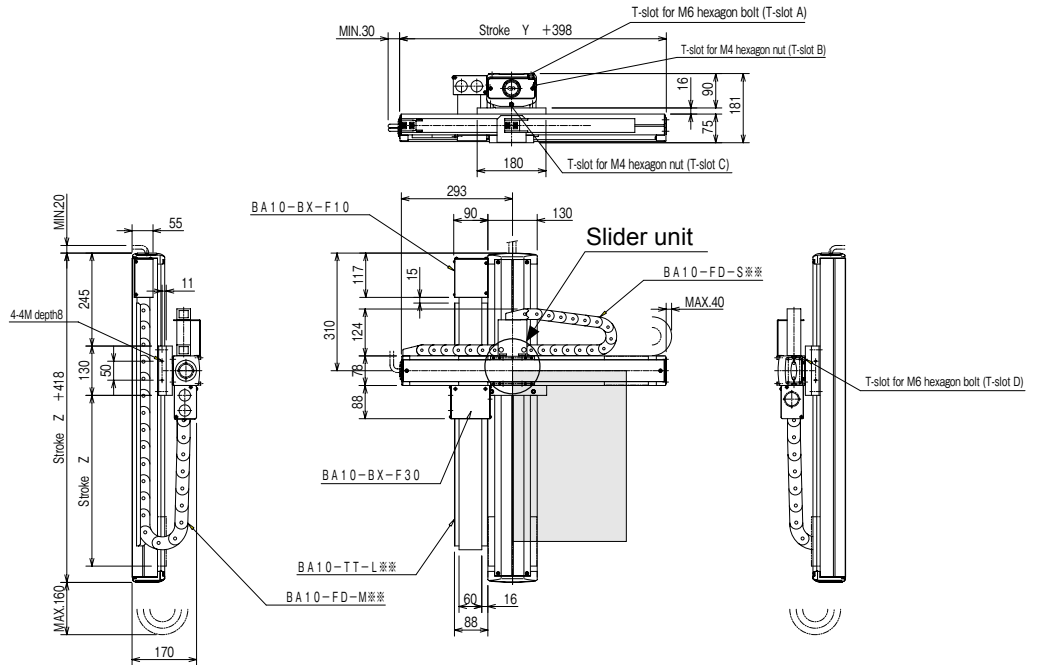
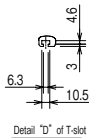
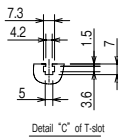
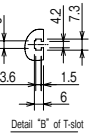
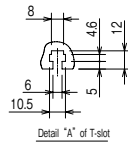

**L: Left-handed**

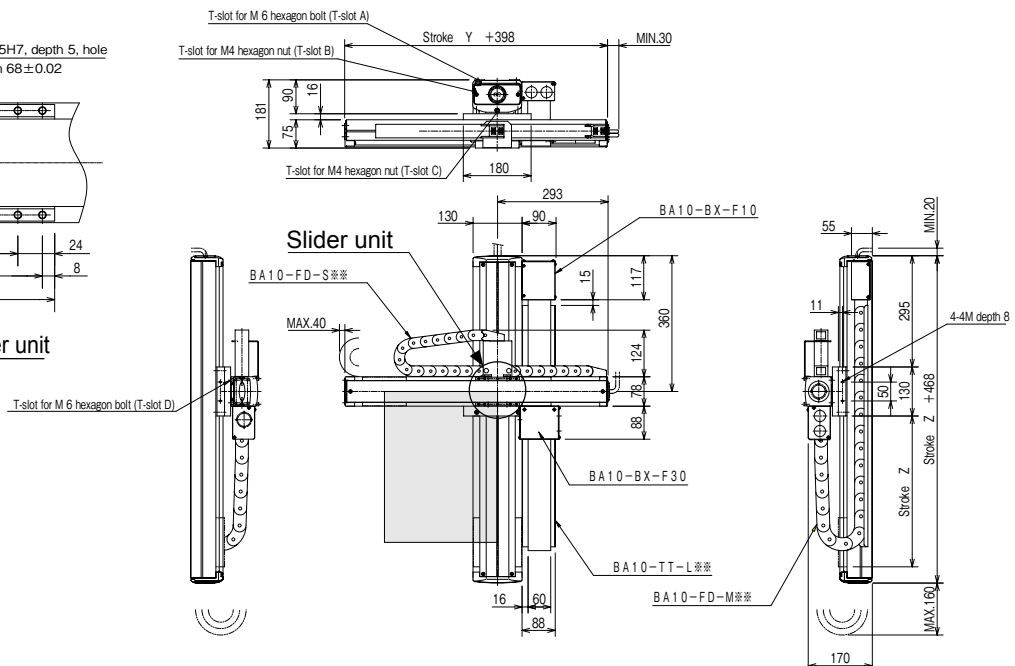
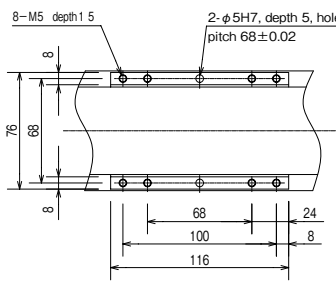

Z-Y Flexible-duct Spec.

[Set designation]

**BA2 – A3 – C2B RA – 40 40 00 – OT 1 3**

Combined operation R: Right-handed L: Left-handed	Axis 1 stroke 10 : 100mm 90 : 900mm A0 : 1000mm	Axis 2 stroke 10 : 100mm 90 : 900mm	Controller 0: None 1: CA20-M10 2: CA10-M00B 3: CA10-M01B	Cable length 3 : 3m 9 : 9m 5 : 5m B : 11m 7 : 7m D : 13m
---	--	---	--	---

**Ball screw type**

Z-axis: Ball screw driven  
Motor straight  
Y-axis: Ball screw driven  
Motor straight

[Specifications]

Z-axis	Z-axis	Y-axis
Type of axis	BB30F-ST-M05B-□ 0	BB10E-ST-M20N-□ 0
Stroke (in increments of 100 mm)	100 ~ 1000mm	100 ~ 900mm
Maximum speed	300 mm/s (Note 1)	1200 mm/s (Note 1)
Positioning repeatability	±0.01mm	
Ball screw lead	5mm	20mm
Motor output	200W, with brake	100W
Resolution	0.01mm	

Note 1: When the stroke is as given below, the maximum speed differs.

	Stroke (mm)	Maximum speed (mm/s)
Z-axis	700	250
	800	200
	900 ~ 1000	150
Y-axis	700	1000
	800	800
	900 ~ 1000	600

Acceleration/deceleration time when the maximum speed is set: 0.36 sec. or over

Maximum Payload (kg) (Note 2)	Y-axis stroke								
	100mm	200mm	300mm	400mm	500mm	600mm	700mm	800mm	900mm
	15.0	15.0	15.0	12.0	9.0	7.0	5.0	3.0	1.0

Note 2: Payload when a regeneration discharge unit (ABSU-2000) is used.

**R: Right-handed**

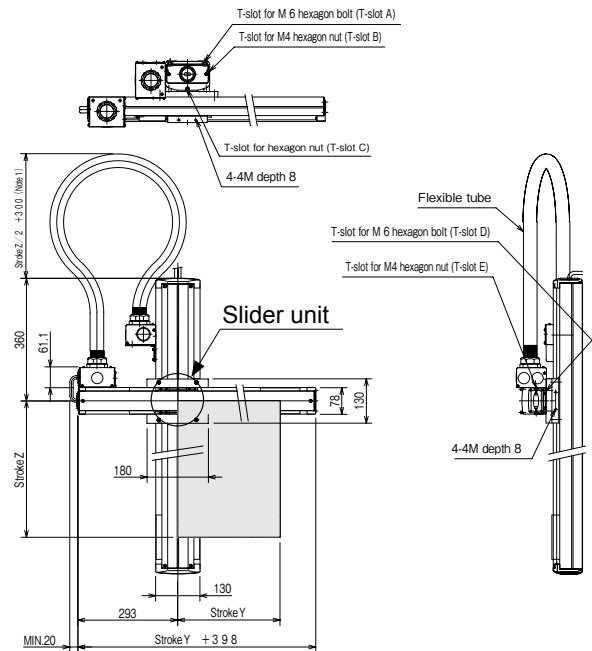
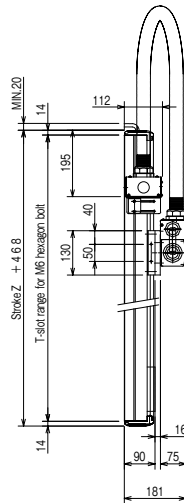
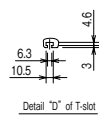
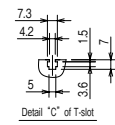
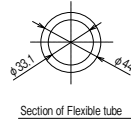
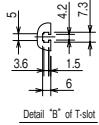
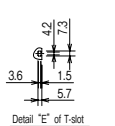
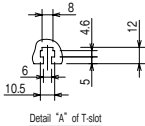

Note 1: The height of the flexible tube is an approximate value.

**L: Left-handed**

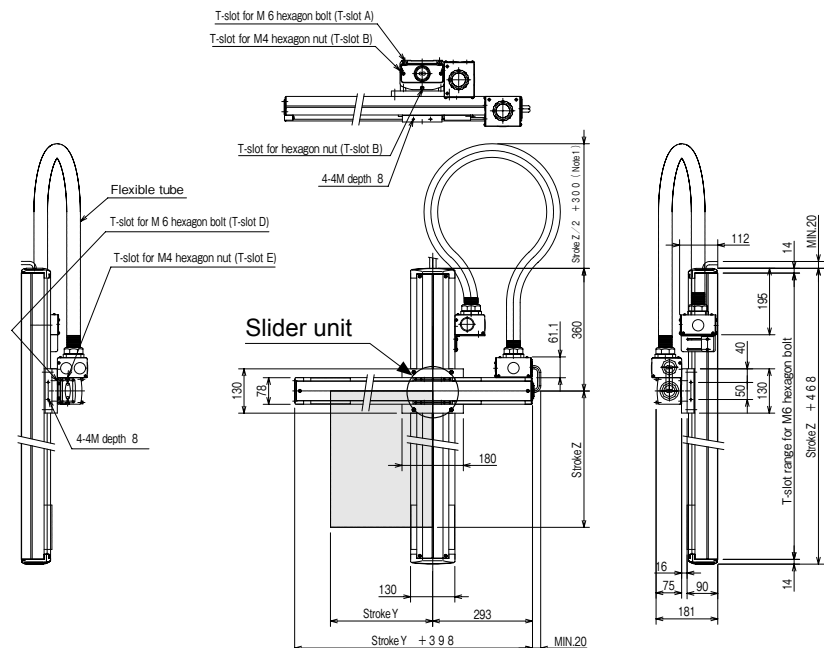
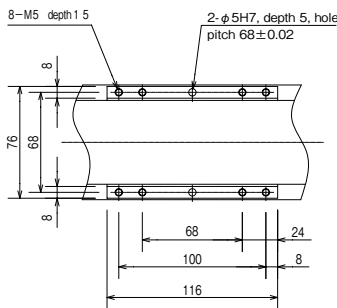

[Set designation]

**BA2 – A5 – C2A RA – 40 45 00 – OF 1 3**

Combined operation  
R: Right-handed  
L: Left-handed

Axis 1 stroke  
20 : 200mm  
90 : 900mm  
A0 : 1000mm  
F0 : 1500mm

Axis 2 stroke  
15 : 150mm  
95 : 950mm  
A5 : 1050mm

Controller  
0: None  
1: CA20-M10  
2: CA10-M00B  
3: CA10-M01B

Cable length  
3 : 3m 9 : 9m  
5 : 5m B : 11m  
7 : 7m D : 13m

**Ball screw type**

Z-axis: Ball screw driven  
Motor straight  
Y-axis: Ball screw driven  
Motor straight

Note 1: When the stroke is as given below, the maximum speed differs.

	Stroke (mm)	Maximum speed (mm/s)
Z-axis	700 ~ 800	280
	900 ~ 1000	250
	1100 ~ 1200	180
	1300	130
	1400	100
Y-axis	750	1000
	850	800
	950 ~ 1050	600

[Specifications]

	Z-axis	Y-axis
Type of axis	BB50F-ST-M05B-□ 0	BB30E-ST-M20N-□ 5
Stroke (in increments of 100 mm)	200 ~ 1500mm	150 ~ 1050mm
Maximum speed	300 mm/s (Note 1)	1200 mm/s (Note 1)
Positioning repeatability	±0.01mm	
Ball screw lead	5mm	20mm
Motor output	200 W, with brake	100W
Resolution	0.01mm	

Acceleration/deceleration time when the maximum speed is set: 0.36 sec. or over

Maximum Payload (kg) (Note 2)	Y-axis stroke									
	150mm	250mm	350mm	450mm	550mm	650mm	750mm	850mm	950mm	1050mm
	20.0	20.0	20.0	20.0	20.0	20.0	18.0	14.0	11.0	7.0

Note 2: Payload when a regeneration discharge unit (ABSU-2000) is used.

**R: Right-handed**

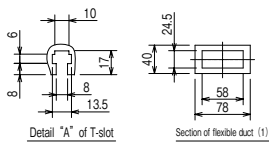

Detail "A" of T-slot

Section of flexible duct (1)

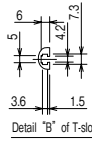

Detail "B" of T-slot

Section of flexible duct (2)

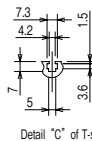

Detail "C" of T-slot

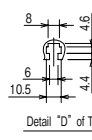

Detail "D" of T-slot

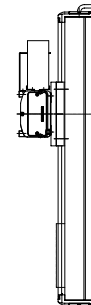
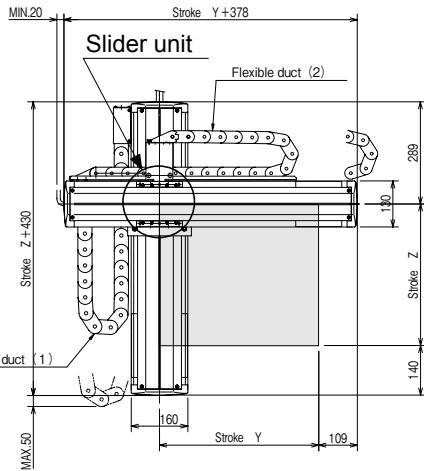
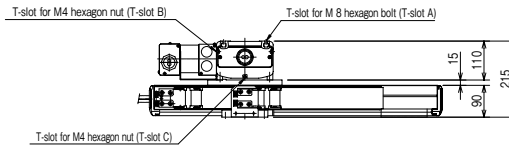

**L: Left-handed**

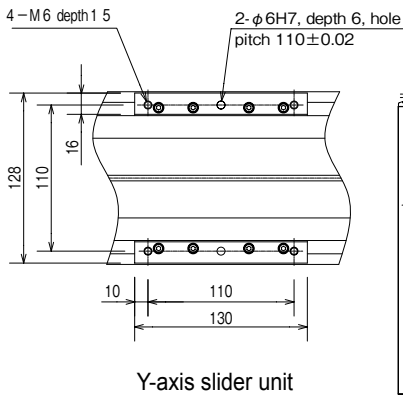

Y-axis slider unit

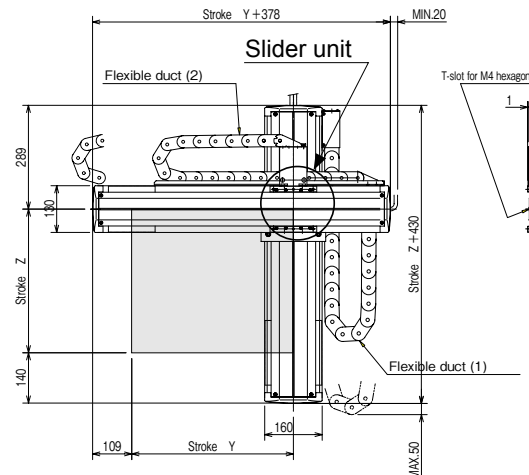
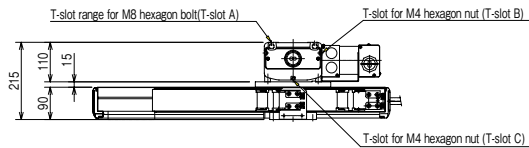

[Set designation]

**BA2 – A5 – C2A RA – 40 45 00 – OT 1 3**

Combined operation  
R: Right-handed  
L: Left-handed

Axis 1 stroke  
20 : 200mm  
90 : 900mm  
A0 : 1000mm  
F0 : 1500mm

Axis 2 stroke  
15 : 150mm  
95 : 950mm  
A5 : 1050mm

Controller  
0: None  
1: CA20-M10  
2: CA10-M00B  
3: CA10-M01B

Cable length  
3 : 3m 9 : 9m  
5 : 5m B : 11m  
7 : 7m D : 13m

**Ball screw type**

Z-axis: Ball screw driven  
Motor straight  
Y-axis: Ball screw driven  
Motor straight

Note 1: When the stroke is as given below, the maximum speed differs.

	Stroke (mm)	Maximum speed (mm/s)
Z-axis	700 ~ 800	280
	900 ~ 1000	250
	1100 ~ 1200	180
	1300	130
	1400	100
Y-axis	1500	80
	750	1000
	850	800
	950 ~ 1050	600

[Specifications]

	Z-axis	Y-axis
Type of axis	BB50F-ST-M05B-□ 0	BB30E-ST-M20N-□ 5
Stroke (in increments of 100 mm)	200 ~ 1500mm	150 ~ 1050mm
Maximum speed	300 mm/s (Note 1)	1200mm/s (Note 1)
Positioning repeatability	±0.01mm	
Ball screw lead	5mm	20mm
Motor output	200 W, with brake	100W
Resolution	0.01mm	

Acceleration/deceleration time when the maximum speed is set: 0.36 sec. or over

Maximum Payload (kg) (Note 2)	Y-axis stroke									
	150mm	250mm	350mm	450mm	550mm	650mm	750mm	850mm	950mm	1050mm
	20.0	20.0	20.0	20.0	20.0	20.0	18.0	14.0	11.0	7.0

Note 2: Payload when a regeneration discharge unit (ABSU-2000) is used.

**R: Right-handed**

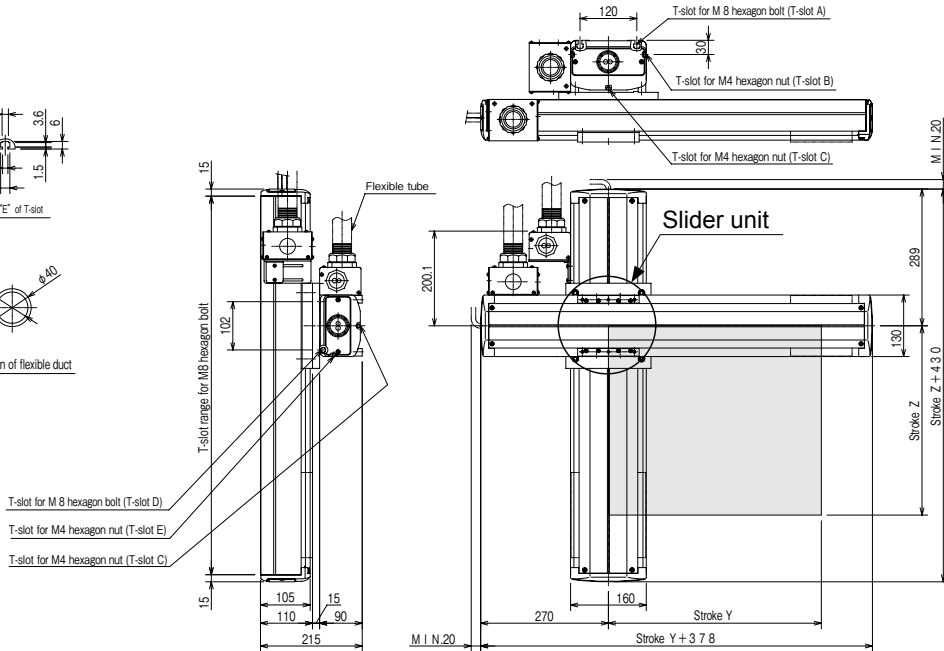
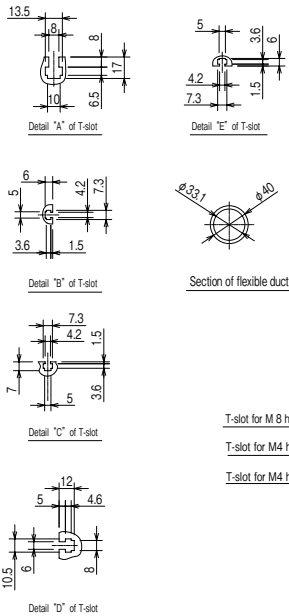

**L: Left-handed**

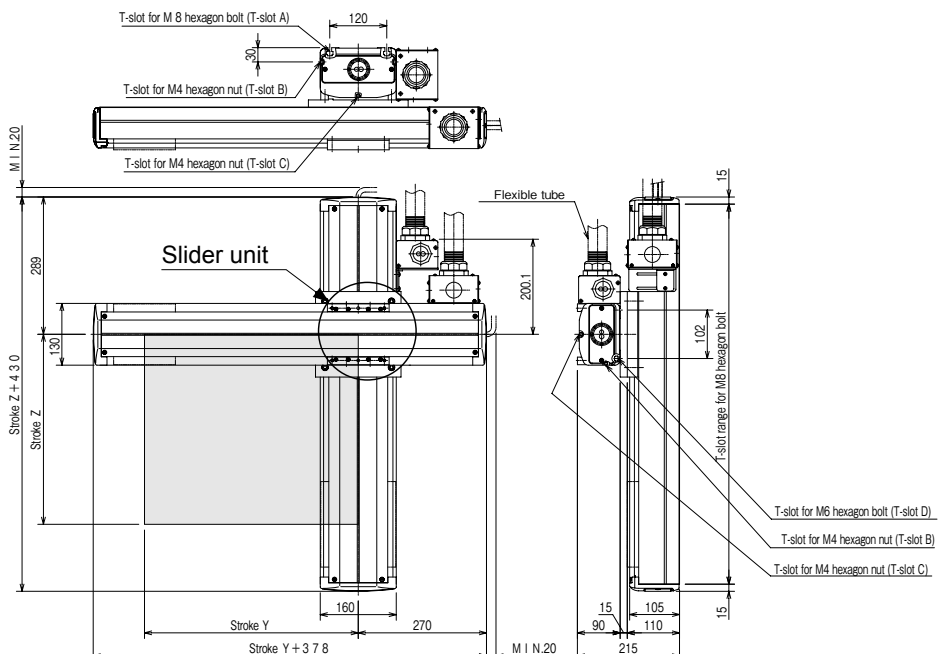
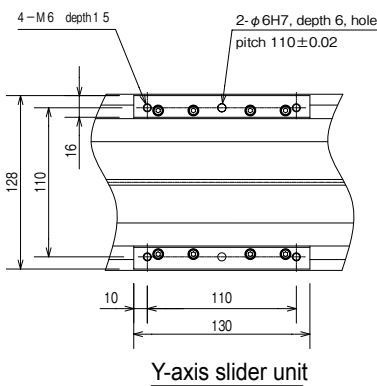

[Set designation]

**BA2 - A5 - C2B RA - 40 45 00 - OF 1 3**

Combined operation R: Right-handed L: Left-handed	Axis 1 stroke 20 : 200mm 90 : 900mm A0 : 1000mm F0 : 1500mm	Axis 2 stroke 10 : 100mm 90 : 900mm A0 : 1000mm	Controller 0: None 1: CA20-M10 2: CA10-M00B 3: CA10-M01B	Cable length 3 : 3m 9 : 9m 5 : 5m B : 11m 7 : 7m D : 13m
---	---	--	--	---

**Ball screw type**

Z-axis: Ball screw driven  
Motor straight  
Y-axis: Ball screw driven  
Motor straight

Note 1: When the stroke is as given below, the maximum speed differs.

	Stroke (mm)	Maximum speed (mm/s)
Z-axis	700 ~ 800	280
	900 ~ 1000	250
	1100 ~ 1200	180
	1300	130
	1400	100
Y-axis	700	1000
	800	800
	900 ~ 1000	600

[Specifications]

	Z-axis	Y-axis
Type of axis	BB50F-ST-M05B-□ 0	BB30F-ST-M20N-□ 0
Stroke (in increments of 100 mm)	200 ~ 1500mm	100 ~ 1000mm
Maximum speed	300 mm/s (Note 1)	1200mm/s (Note 1)
Positioning repeatability	±0.01mm	
Ball screw lead	5mm	20mm
Motor output	200 W, with brake	200W
Resolution	0.01mm	

Acceleration/deceleration time when the maximum speed is set: 0.36 sec. or over

Maximum Payload (kg) (Note 2)	Y-axis stroke									
	100mm	200mm	300mm	400mm	500mm	600mm	700mm	800mm	900mm	1000mm
	38.0	37.0	36.0	34.0	29.0	23.0	18.0	14.0	11.0	7.0

Note 2: Payload when a regeneration discharge unit (ABSU-2000) is used.

**R: Right-handed**

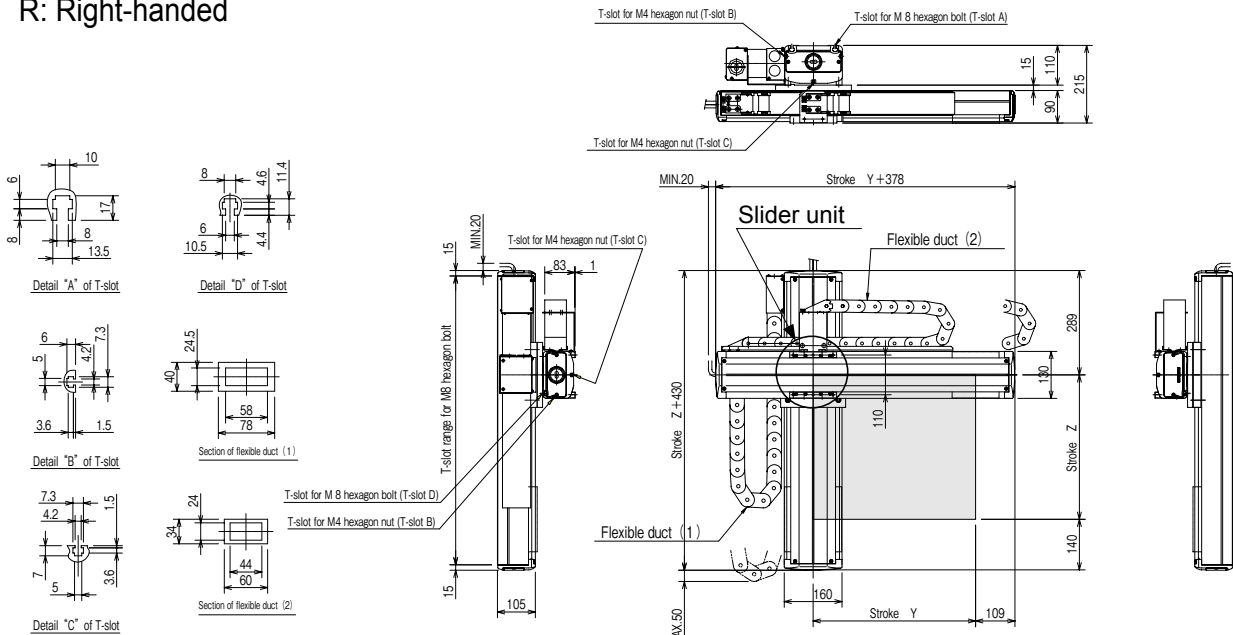

**L: Left-handed**

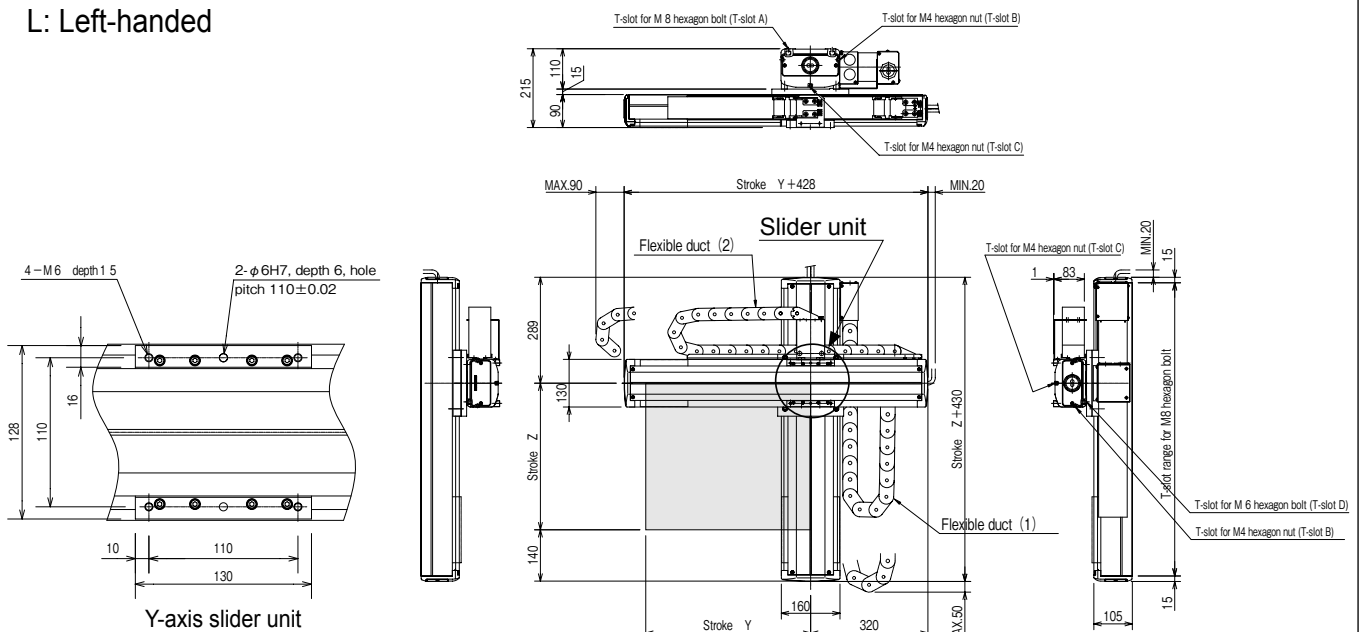

Z-Y Flexible-duct Spec.

[Set designation]

**BA2 – A5 – C2B RA – 40 40 00 – OT 1 3**

Combined operation	Axis 1 stroke	Axis 2 stroke	Controller	Cable length
R: Right-handed	20 : 200mm	10 : 100mm	0: None	3 : 3m 9 : 9m
L: Left-handed	90 : 900mm	90 : 900mm	1: CA20-M10	5 : 5m B : 11m
	A0 : 1000mm	A0 : 1000mm	2: CA10-M00B	7 : 7m D : 13m
	F0 : 1500mm		3: CA10-M01B	

**Ball screw type**

Z-axis: Ball screw driven  
Motor straight  
Y-axis: Ball screw driven  
Motor straight

Note 1: When the stroke is as given below, the maximum speed differs.

	Stroke (mm)	Maximum speed (mm/s)
Z-axis	700 ~ 800	280
	900 ~ 1000	250
	1100 ~ 1200	180
	1300	130
	1400	100
Y-axis	700	1000
	800	800
	900 ~ 1000	600

[Specifications]

	Z-axis	Y-axis
Type of axis	BB50F-ST-M05B-□ 0	BB30F-ST-M20N-□ 0
Stroke (in increments of 100 mm)	200 ~ 1500mm	100 ~ 1000mm
Maximum speed	300 mm/s (Note 1)	1200mm/s (Note 1)
Positioning repeatability	±0.01mm	
Ball screw lead	5mm	20mm
Motor output	200 W, with brake	200W
Resolution	0.01mm	

Acceleration/deceleration time when the maximum speed is set: 0.36 sec. or over

Maximum Payload (kg) (Note 2)	Y-axis stroke									
	100mm	200mm	300mm	400mm	500mm	600mm	700mm	800mm	900mm	1000mm
	38.0	37.0	36.0	34.0	29.0	23.0	18.0	14.0	11.0	7.0

Note 2: Payload when a regeneration discharge unit (ABSU-2000) is used.

**R: Right-handed**

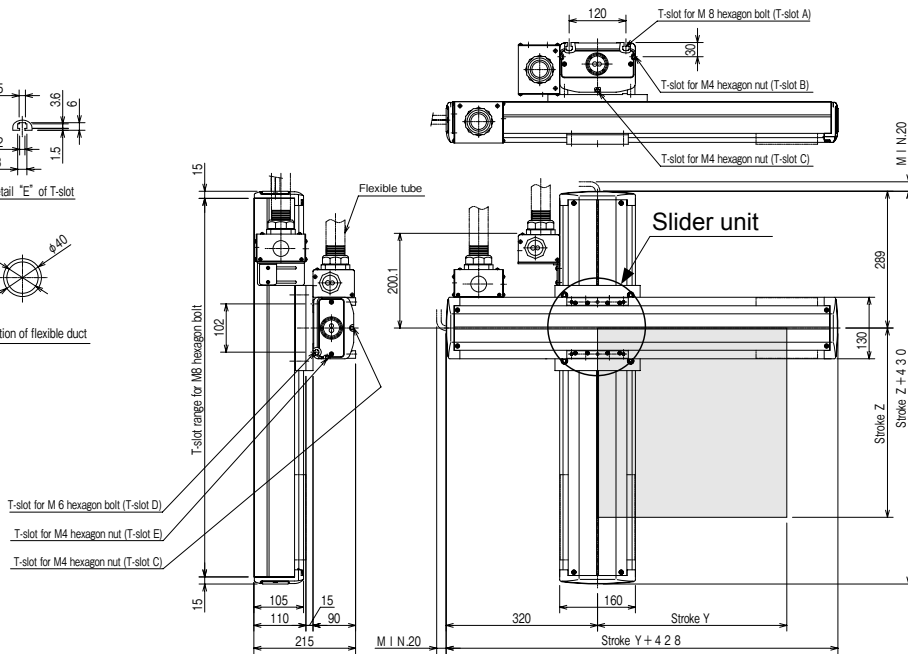
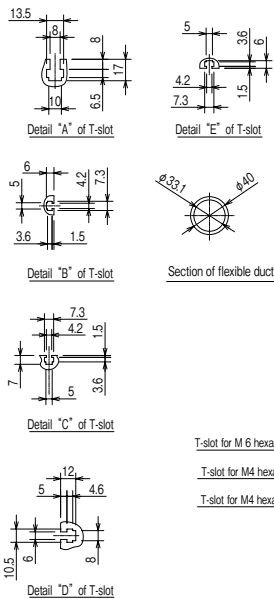

**L: Left-handed**

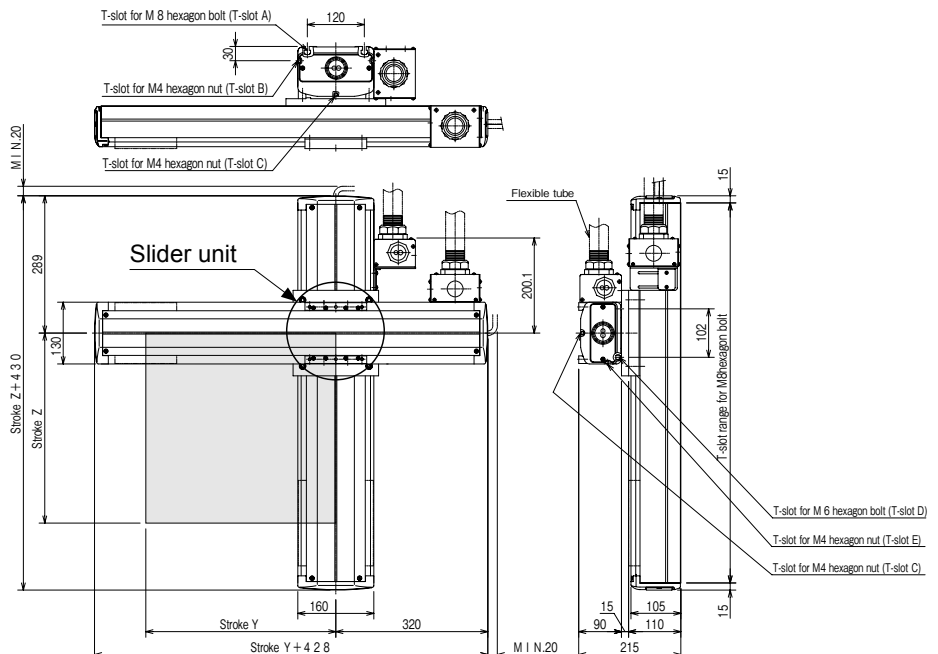
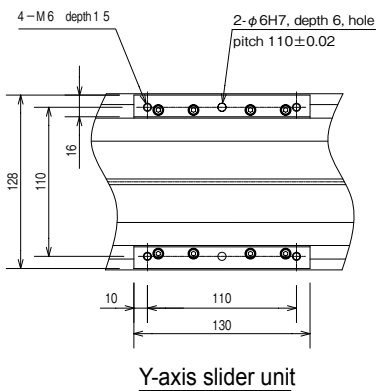

[Set designation]

BA2 - A1 - L2A R L - 40 45 00 - OF 1 3

Combined operation R: Right-handed L: Left-handed	Axis 1 stroke 10 : 100mm 90 : 900mm A0 : 1000mm	Axis 2 stroke 15 : 150mm 65 : 650mm	Controller 0: None 1: CA20-M10 2: CA10-M00B 3: CA10-M01B	Cable length 3 : 3m 9 : 9m 5 : 5m B : 11m 7 : 7m D : 13m
---	--	---	--	---

Timing belt type

- Z-axis: Ball screw driven  
Motor straight
- Y-axis: Timing belt driven  
Side mounted motor

[Specifications]

	Z-axis	Y-axis
Type of axis	BB10E-ST-M05B- □ 0	BB10E-B □ -S21N- □ 5
Stroke (in increments of 100 mm)	100 ~ 1000mm	150 ~ 650mm
Maximum speed	300 mm/s (Note 1)	1000mm/s
Positioning repeatability	±0.01mm	±0.05mm
Ball screw lead	5mm	21 mm (lead converted into ball screw)
Motor output	100 W, with brake	100W
Resolution	0.01mm	

Acceleration/deceleration time when the maximum speed is set: 0.36 sec. or over

Note 1: When the stroke is as given below, the maximum speed differs.

	Stroke (mm)	Maximum speed (mm/s)
Z-axis	700	250
	800	200
	900 ~ 1000	150

Maximum Payload (kg) (Note 2)	Z-axis stroke					
	150mm	250mm	350mm	450mm	550mm	650mm
	15.0	12.0	9.0	6.0	5.0	3.0

Note 2: Payload when a regeneration discharge unit (ABSU-2000) is used.

R: Right-handed

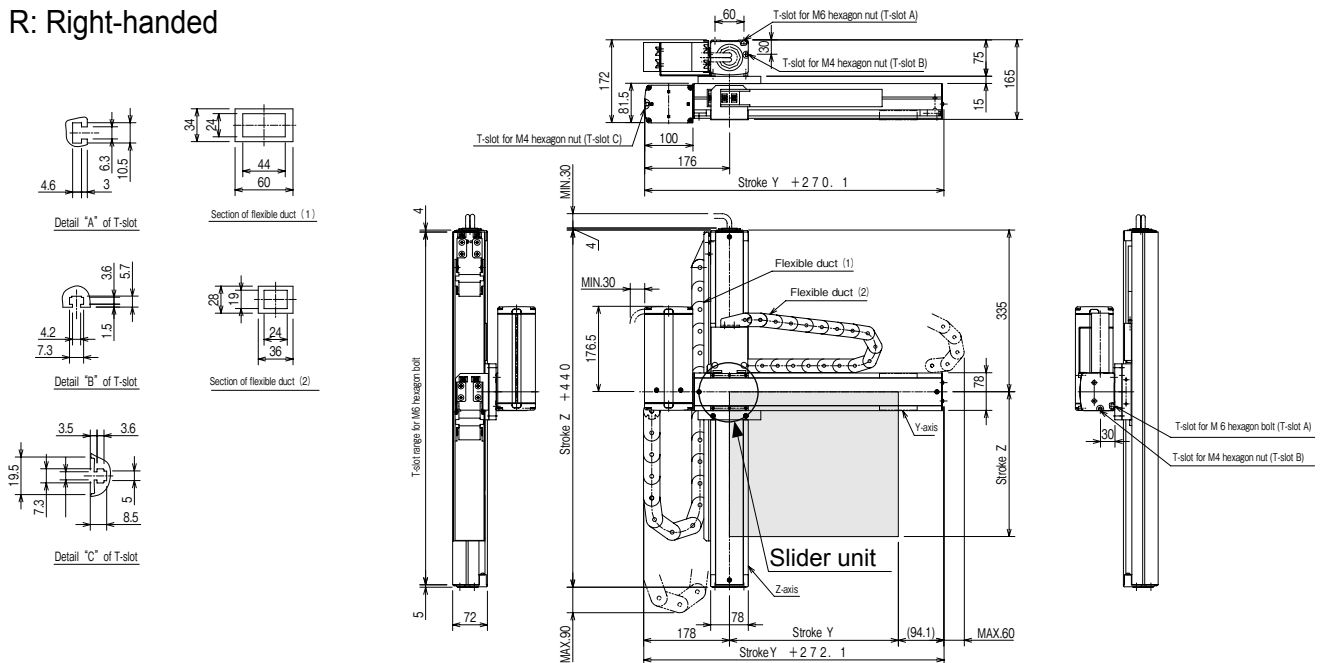

L: Left-handed

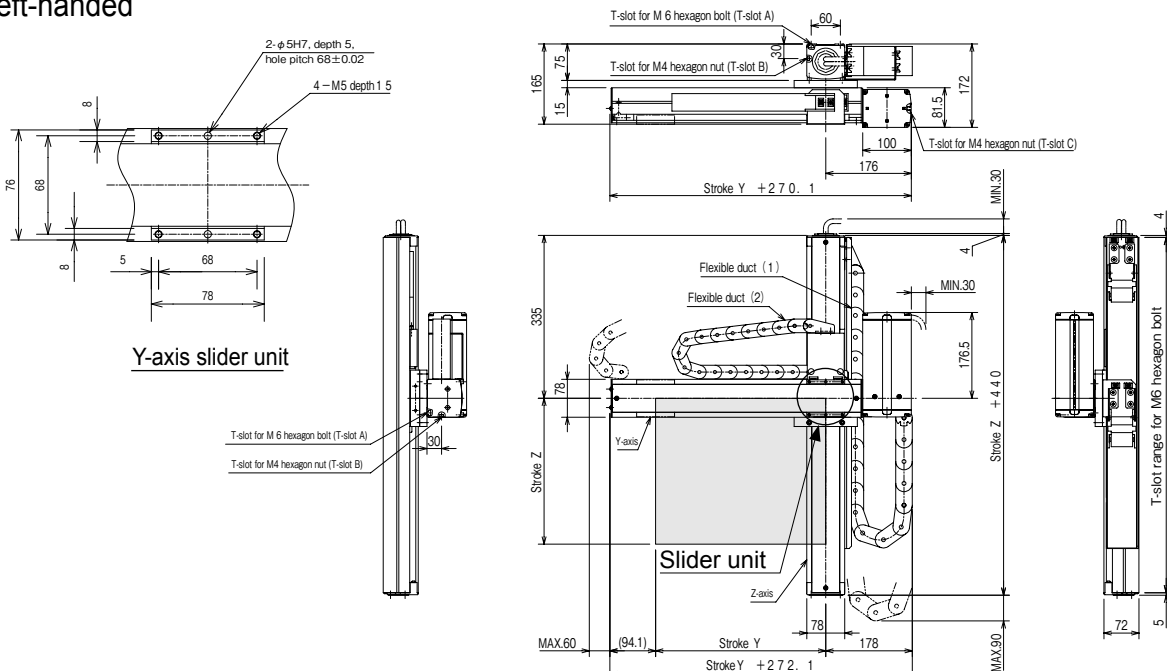

Z-Y Flexible-duct Spec.

[Set designation]

BA2 - A3 - L2A R L - 45 40 00 - OF 1 3

Combined operation R: Right-handed L: Left-handed	Axis 1 stroke 15 : 150mm 95 : 950mm A5 : 1050mm	Axis 2 stroke 10 : 100mm 80 : 800mm	Controller 0: None 1: CA20-M10 2: CA10-M00B 3: CA10-M01B	Cable length 3 : 3m 9 : 9m 5 : 5m B : 11m 7 : 7m D : 13m
---	--	---	--	---

Timing belt type

- Z-axis: Ball screw driven  
Motor straight
- Y-axis: Timing belt driven  
Side mounted motor

[Specifications]

	Z-axis	Y-axis
Type of axis	BB30E-ST-M05B-□ 5	BB10E-B □ -M21N-□ 0
Stroke (in increments of 100 mm)	150 ~ 1050mm	100 ~ 800mm
Maximum speed	300 mm/s (Note 1)	1000mm/s
Positioning repeatability	±0.01mm	±0.05mm
Ball screw lead	5mm	21 mm (lead converted into ball screw)
Motor output	100 W, with brake	100W
Resolution	0.01mm	

Note 1: When the stroke is as given below, the maximum speed differs.

	Stroke (mm)	Maximum speed (mm/s)
Z-axis	750	250
	850	200
	950 ~ 1050	150

Acceleration/deceleration time when the maximum speed is set: 0.36 sec. or over

Maximum Payload (kg) (Note 2)	Z-axis stroke							
	100mm	200mm	300mm	400mm	500mm	600mm	700mm	800mm
	15.0	15.0	15.0	12.0	8.0	6.0	4.0	1.0

Note 2: Payload when a regeneration discharge unit (ABSU-2000) is used.

R: Right-handed

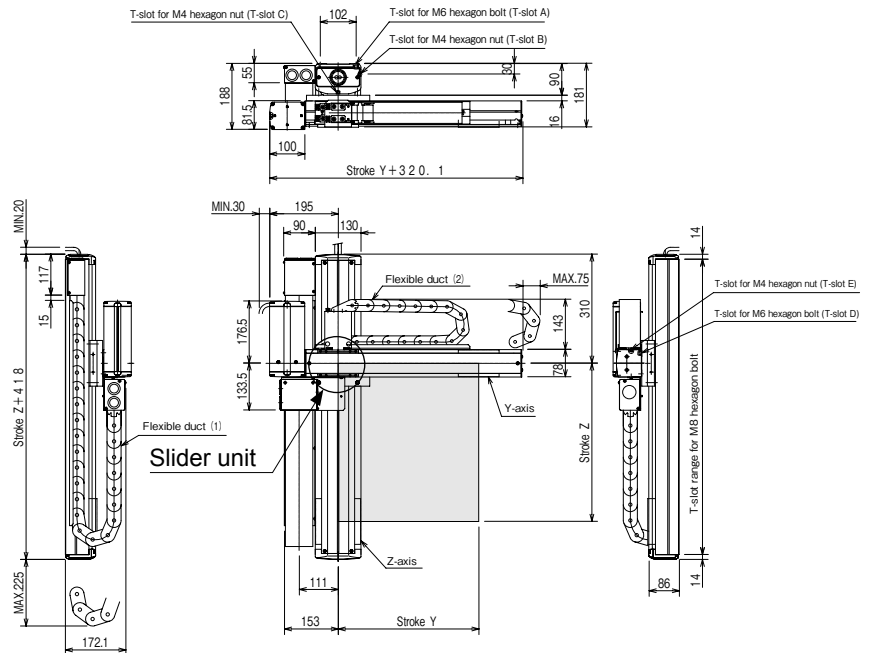
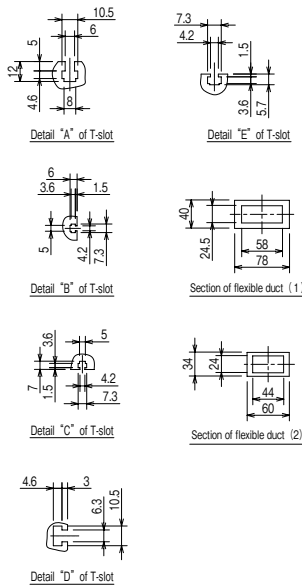

L: Left-handed

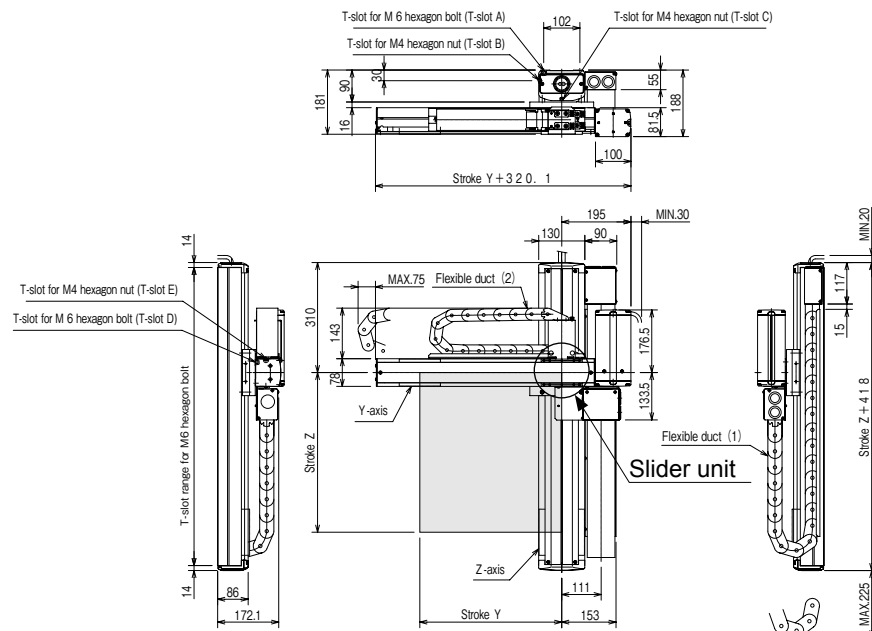
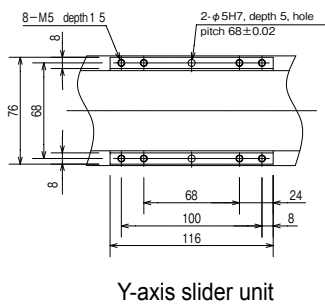

Z-Y Flexible-duct Spec.



[Set designation]

**BA2 - A3 - L2B R L - 40 40 00 - OF 1 3**

Combined operation R: Right-handed L: Left-handed	Axis 1 stroke 10 : 100mm 90 : 900mm A0 : 1000mm	Axis 2 stroke 10 : 100mm 90 : 900mm	Controller 0: None 1: CA20-M10 2: CA10-M00B 3: CA10-M01B	Cable length 3 : 3m 9 : 9m 5 : 5m B : 11m 7 : 7m D : 13m
---	--	---	--	---

**Timing belt type**

- Z-axis: Ball screw driven  
Motor straight
- Y-axis: Timing belt driven  
Side mounted motor

[Specifications]

	Z-axis	Y-axis
Type of axis	BB30F-ST-M05B-□ 0	BB10E-B □ -M21N-□ 0
Stroke (in increments of 100 mm)	100 ~ 1000mm	100 ~ 900mm
Maximum speed	300mm/s (Note 1)	1000mm/s
Positioning repeatability	±0.01mm	±0.05mm
Ball screw lead	5mm	21 mm (lead converted into ball screw)
Motor output	200 W, with brake	100W
Resolution	0.01mm	

Acceleration/deceleration time when the maximum speed is set: 0.36 sec. or over

Note 1: When the stroke is as given below, the maximum speed differs.

	Stroke (mm)	Maximum speed (mm/s)
Z-axis	700	250
	800	200
	900 ~ 1000	150

Maximum Payload (kg) (Note 2)	Z-axis stroke								
	100mm	200mm	300mm	400mm	500mm	600mm	700mm	800mm	900mm
	15.0	15.0	15.0	12.0	9.0	7.0	5.0	3.0	1.0

Note 2: Payload when a regeneration discharge unit (ABSU-2000) is used.

**R: Right-handed**

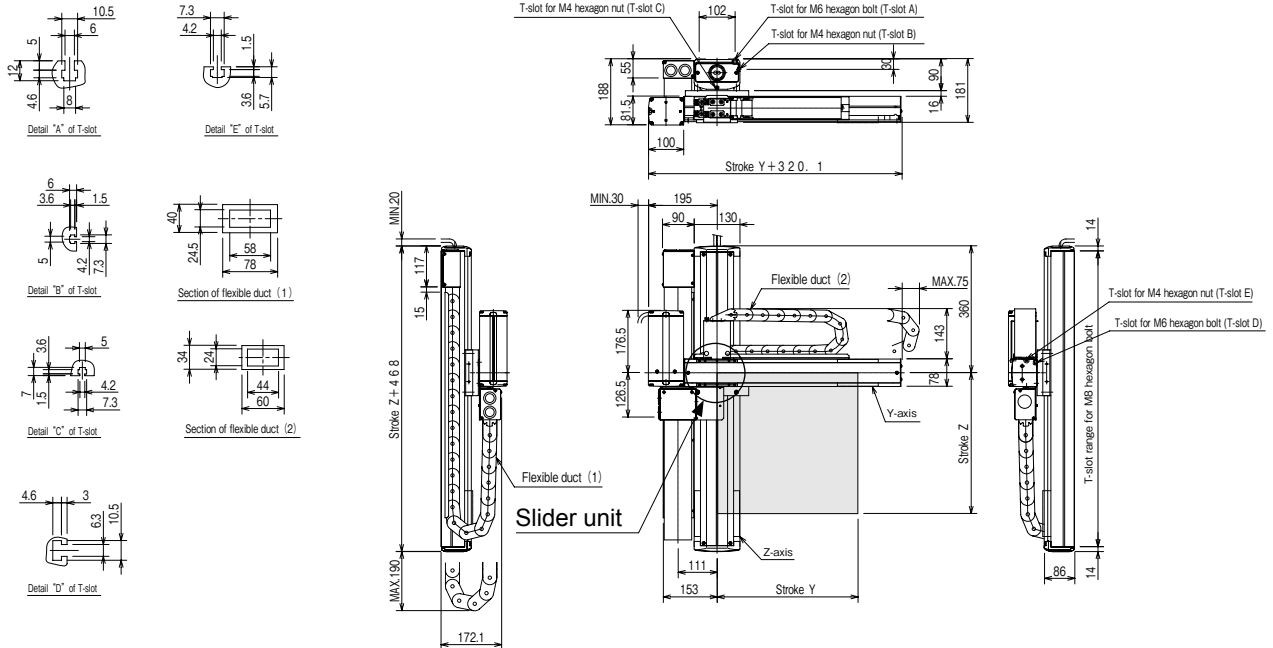

**L: Left-handed**

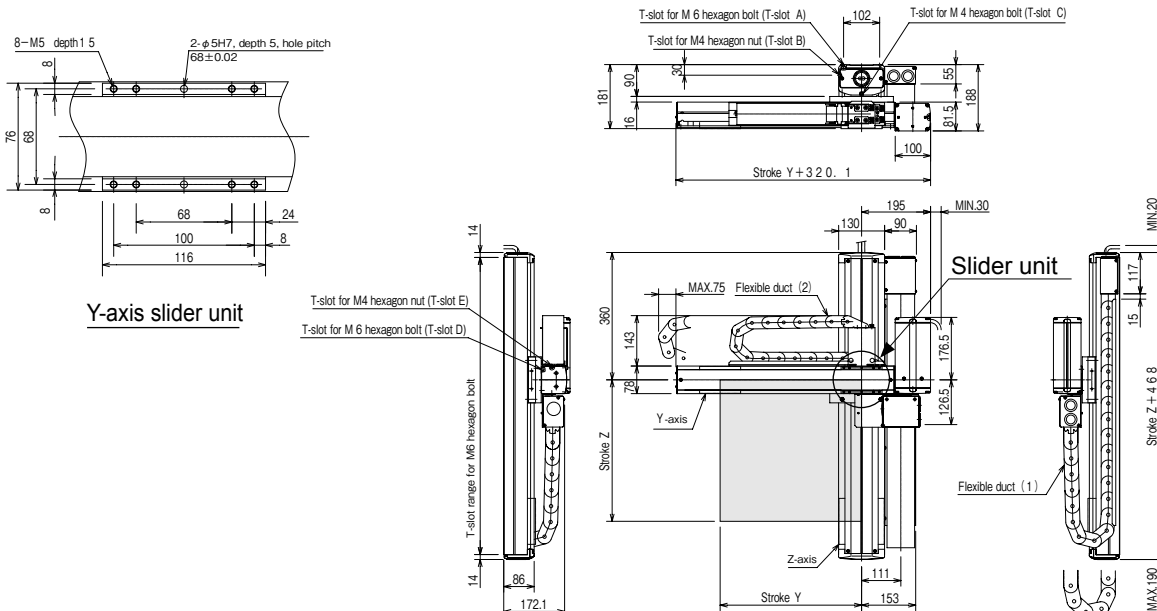

Z-Y Flexible-duct Spec.

[Set designation]

**BA2 – A3 – L2C R L – 40 40 00 – OF 1 3**

Combined operation	Axis 1 stroke	Axis 2 stroke	Controller	Cable length
R: Right-handed L: Left-handed	10 : 100mm 90 : 900mm A0 : 1000mm	10 : 100mm 90 : 900mm	0: None 1: CA20-M10 2: CA10-M00B 3: CA10-M01B	3 : 3m 9 : 9m 5 : 5m B : 11m 7 : 7m D : 13m

**Timing belt type**

- Z-axis: Ball screw driven  
Motor straight
- Y-axis: Timing belt driven  
Side mounted motor

[Specifications]

	Z-axis	Y-axis
Type of axis	BB30F-ST-M05B-□ 0	BB10F-B □ -M21N-□ 0
Stroke (in increments of 100 mm)	100 ~ 1000mm	100 ~ 900mm
Maximum speed	300 mm/s (Note 1)	1000mm/s
Positioning repeatability	±0.01mm	±0.05mm
Ball screw lead	5mm	21 mm (lead converted into ball screw)
Motor output	200 W, with brake	200W
Resolution	0.01mm	

Acceleration/deceleration time when the maximum speed is set: 0.36 sec. or over

Note 1: When the stroke is as given below, the maximum speed differs.

	Stroke (mm)	Maximum speed (mm/s)
Z-axis	700	250
	800	200
	900 ~ 1000	150

Maximum Payload (kg) (Note 2)	Z-axis stroke								
	100mm	200mm	300mm	400mm	500mm	600mm	700mm	800mm	900mm
	20.0	19.0	15.0	12.0	9.0	7.0	5.0	3.0	1.0

Note 2: Payload when a regeneration discharge unit (ABSU-2000) is used.

R: Right-handed

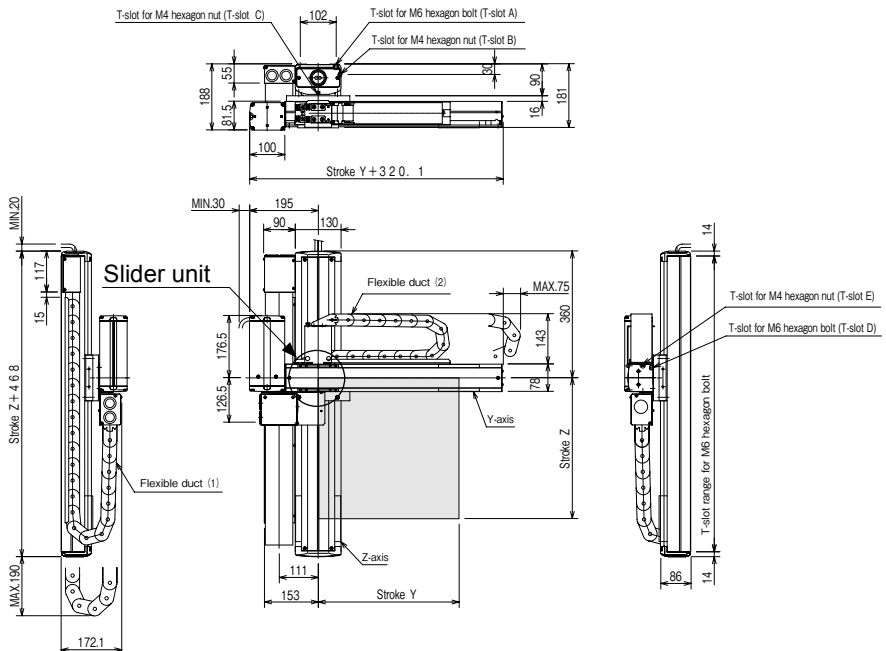
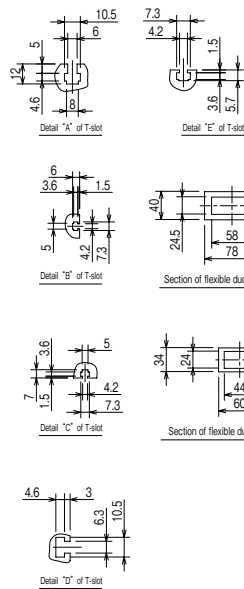

L :

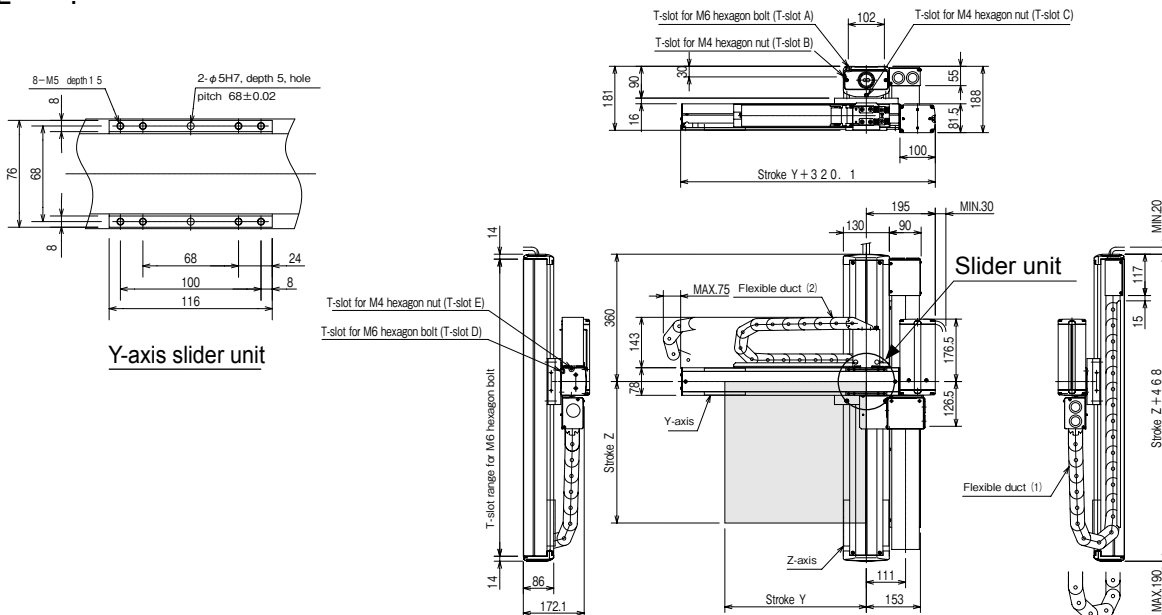

Z-Y Flexible-duct Spec.

[Set designation]

**BA2 – A5 – L2A RL – 40 40 00 – OF 1 3**

Combined operation R: Right-handed L: Left-handed	Axis 1 stroke 20 : 200mm 90 : 900mm A0 : 1000mm F0 : 1500mm	Axis 2 stroke 10 : 100mm 90 : 900mm A0 : 1000mm	Controller 0: None 1: CA20-M10 2: CA10-M00B 3: CA10-M01B	Cable length 3 : 3m 9 : 9m 5 : 5m B : 11m 7 : 7m D : 13m
---	---	--	--	---

Timing belt type

Z-axis: Ball screw driven  
Motor straight  
Y-axis: Timing belt driven  
Side mounted motor

[Specifications]

	Z-axis	Y-axis
Type of axis	BB50F-ST-M05B-□ 0	BB30E-B □ -M21N- □ 0
Stroke (in increments of 100 mm)	200 ~ 1500mm	100 ~ 1000mm
Maximum speed	300 mm/s (Note 1)	1000mm/s
Positioning repeatability	±0.01mm	±0.05mm
Ball screw lead	5mm	21 mm (lead converted into ball screw)
Motor output	200 W, with brake	100W
Resolution	0.01mm	

Acceleration/deceleration time when the maximum speed is set: 0.36 sec. or over

Note 1: When the stroke is as given below, the maximum speed differs.

	Stroke (mm)	Maximum speed (mm/s)
Z-axis	700 ~ 800	280
	900 ~ 1000	250
	1100 ~ 1200	180
	1300	130
	1400	100
	1500	80

Maximum Payload (kg) (Note 2)	Y-axis stroke									
	100mm	200mm	300mm	400mm	500mm	600mm	700mm	800mm	900mm	1000mm
	15.0	15.0	15.0	15.0	15.0	15.0	15.0	14.0	11.0	7.0

Note 2: Payload when a regeneration discharge unit (ABSU-2000) is used.

R: Right-handed

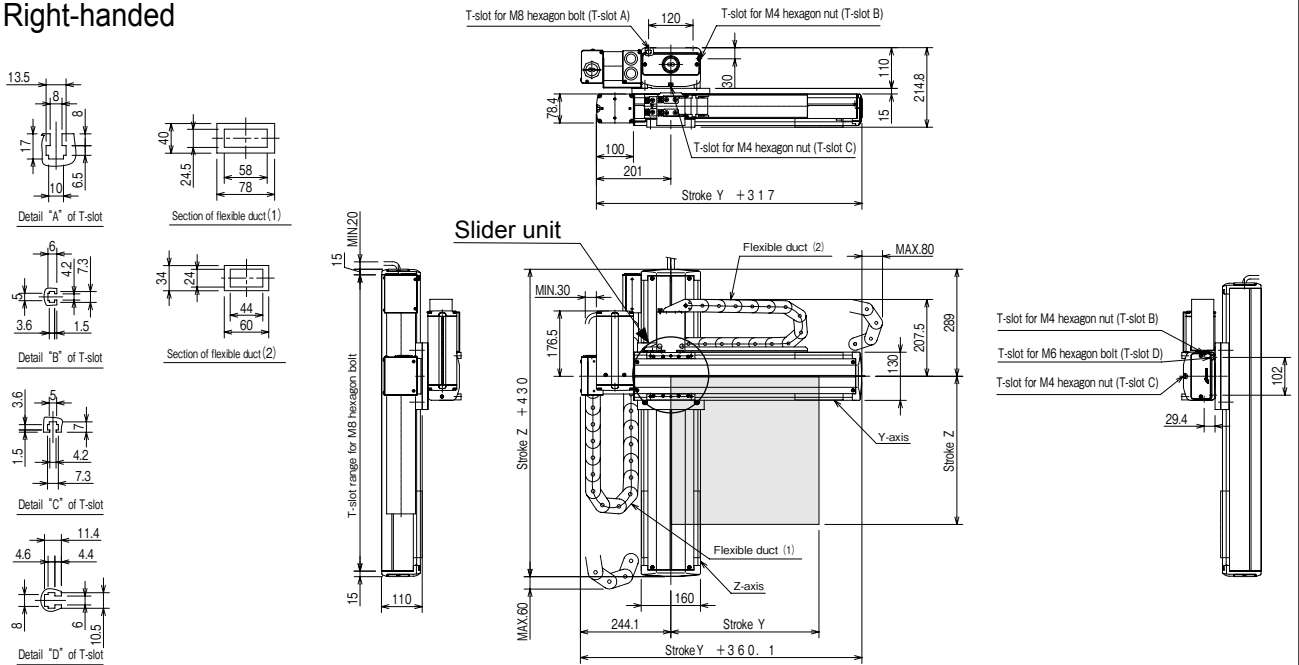

L: Left-handed

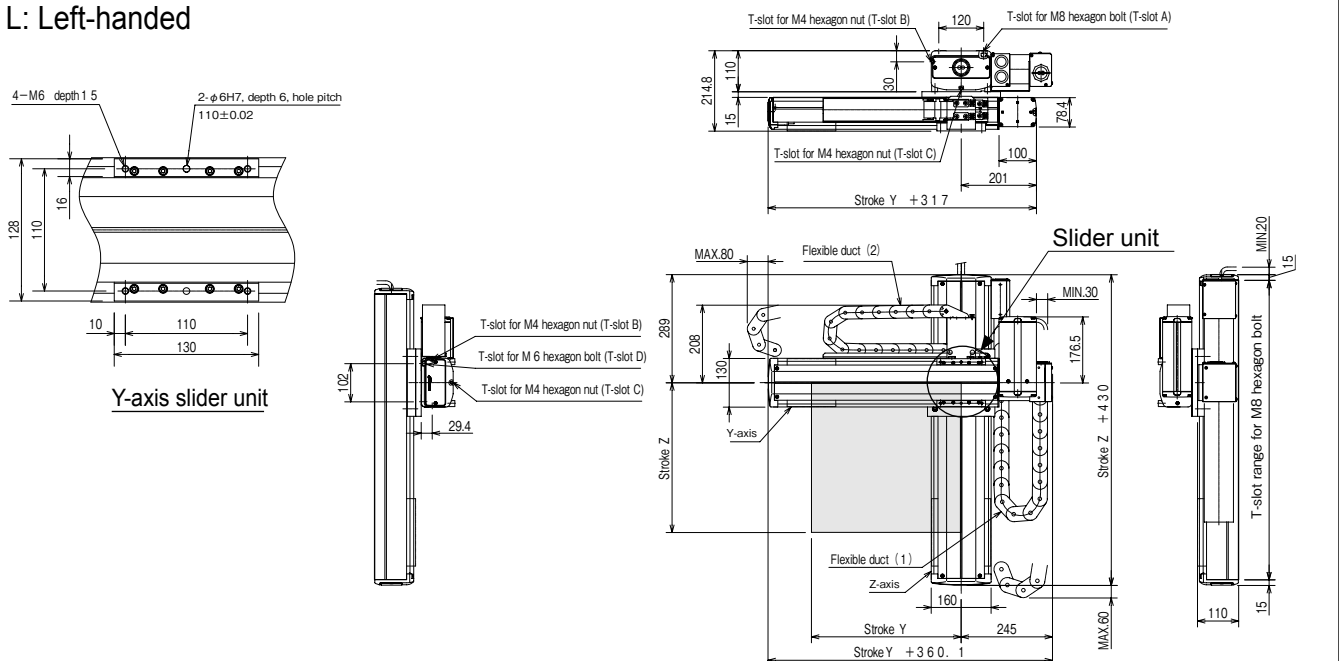

Z-Y Flexible-duct Spec.

[Set designation]

**BA2 - A5 - L2B RL - 40 40 00 - OF 1 3**

Combined operation	Axis 1 stroke	Axis 2 stroke	Controller	Cable length	
R: Right-handed	20 : 200mm	10 : 100mm	0: None	3 : 3m	9 : 9m
L: Left-handed	90 : 900mm	90 : 900mm	1: CA20-M10	5 : 5m	B : 11m
	A0 : 1000mm	A0 : 1000mm	2: CA10-M00B	7 : 7m	D : 13m
	F0 : 1500mm		3: CA10-M01B		

**Timing belt type**

- Z-axis: Ball screw driven  
Motor straight
- Y-axis: Timing belt driven  
Side mounted motor

[Specifications]

	Z-axis	Y-axis
Type of axis	BB50F-ST-M05B-□ 0	BB30F-B□ -M21N-□ 0
Stroke (in increments of 100 mm)	200 ~ 1500mm	100 ~ 1000mm
Maximum speed	300mm/s (注 1)	1000mm/s
Positioning repeatability	±0.01mm	±0.05mm
Ball screw lead	5mm	21 mm (lead converted into ball screw)
Motor output	200 W, with brake	200W
Resolution	0.01mm	

Note 1: When the stroke is as given below, the maximum speed differs.

Z-axis	Stroke (mm)	Maximum speed (mm/s)
	700 ~ 800	280
900 ~ 1000	250	
1100 ~ 1200	180	
1300	130	
1400	100	
1500	80	

Acceleration/deceleration time when the maximum speed is set: 0.36 sec. or over

Maximum Payload (kg) (Note 2)	Y-axis stroke									
	100mm	200mm	300mm	400mm	500mm	600mm	700mm	800mm	900mm	1000mm
	37.0	36.0	35.0	34.0	29.0	23.0	18.0	14.0	11.0	7.0

Note 2: Payload when a regeneration discharge unit (ABSU-2000) is used.

**R: Right-handed**

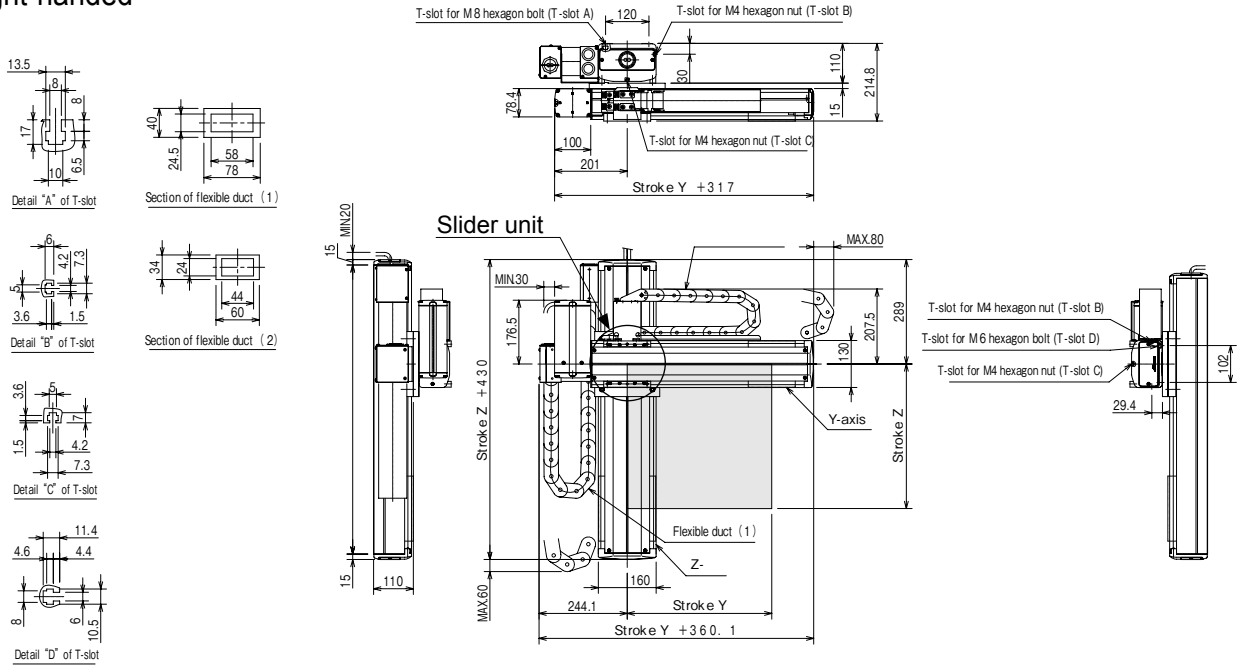

**L: Left-handed**

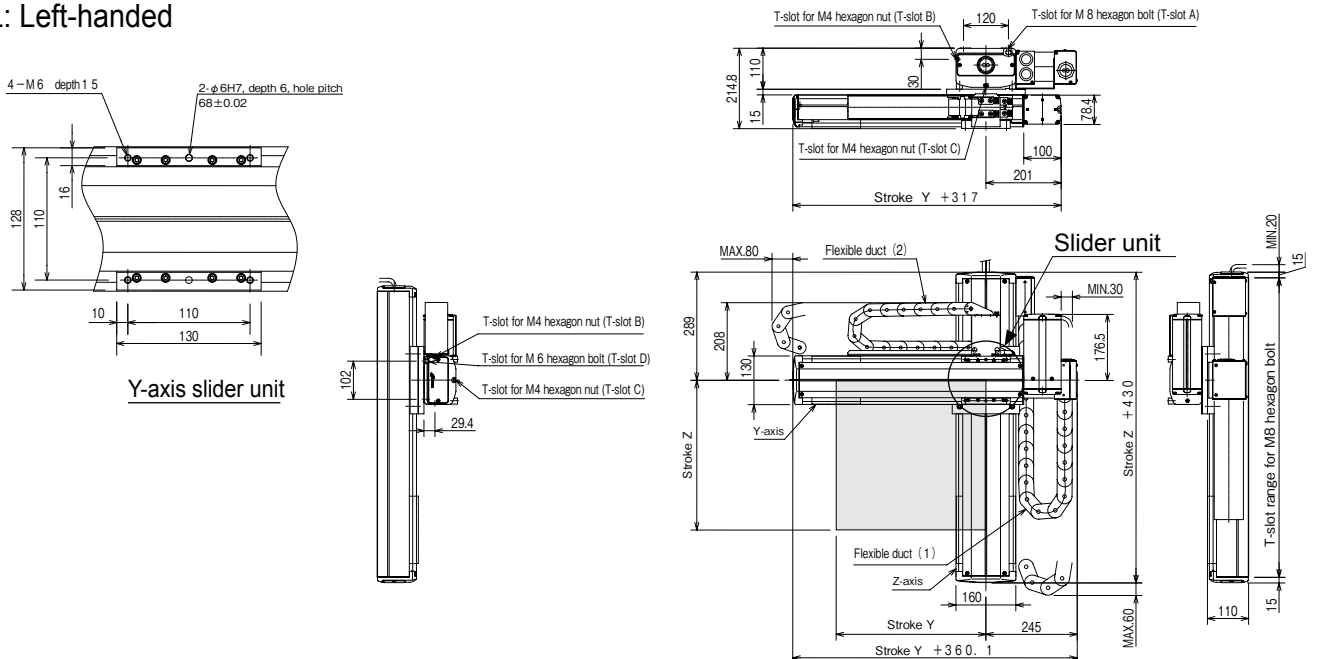

[Set designation]

**BA2 – A1 – A3A R A – 45 30 30 – OF 2 3**

Ball screw type

- X-axis: Ball screw driven  
Motor straight
- Y-axis: Ball screw driven  
Motor straight
- Z-axis: Ball screw driven  
Motor straight

Combined operation R: Right-handed L: Left-handed	Axis 1 stroke 15 : 150mm 95 : 950mm A5 : 1050mm	Axis 2 stroke 05 : 50mm 30 : 300mm	Axis 3 stroke 05 : 50mm 30 : 300mm	Controller 0: None 1: CA20-M10 2: CA10-M00B 3: CA10-M01B	Cable length 3 : 3m 9 : 9m 5 : 5m B : 11m 7 : 7m D : 13m
---	--	--	--	--	---

[Specifications]

	X-axis	Y-axis	Z-axis
Type of axis	BB10E-ST-S20N- □ 5	BB07D-ST-M12N- □ □	BB05D-ST-M12B- □ □
Stroke (X-axis in increments of 100 mm, Y- and Z-axes in increments of 50 mm)	150 ~ 1050mm	50 ~ 300mm	50 ~ 300mm
Maximum speed	1200 mm/s (Note 1)	800mm/s	800mm/s
Positioning repeatability	±0.01mm	±0.02mm	±0.02mm
Ball screw lead	20mm	12mm	12mm
Motor output	100W	50W	50 W, with brake
Resolution	0.01mm		

Note 1: When the stroke is as given below, the maximum speed differs.

	Stroke (mm)	Maximum speed (mm/s)
X-axis	750	1000
	850	800
	950 ~ 1050	600

Acceleration/deceleration time when the maximum speed is set: 0.36 sec. or over

Maximum Payload (kg)		Y-axis stroke					
		50mm	100mm	150mm	200mm	250mm	300mm
Z-axis stroke	50,100mm	3.0	3.0	3.0	3.0	1.2	1.2
	150,200mm	3.0	3.0	3.0	3.0	1.0	1.0
	250,300mm	3.0	3.0	3.0	3.0	0.8	0.8

R: Right-handed

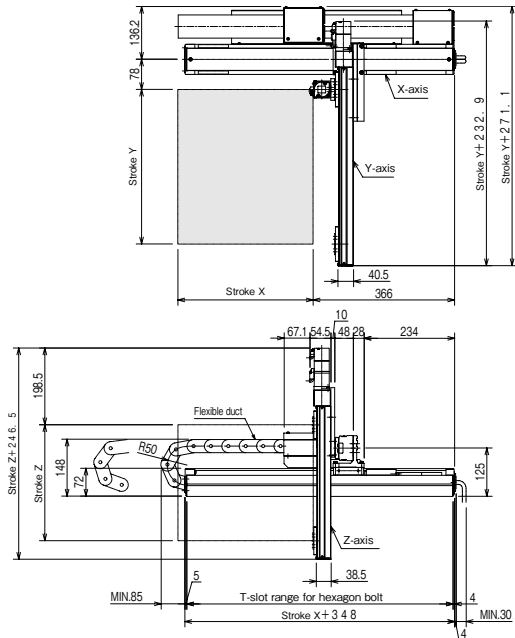
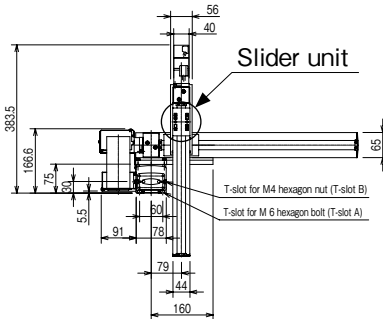
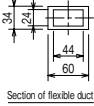
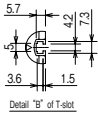
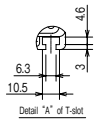

L: Left-handed

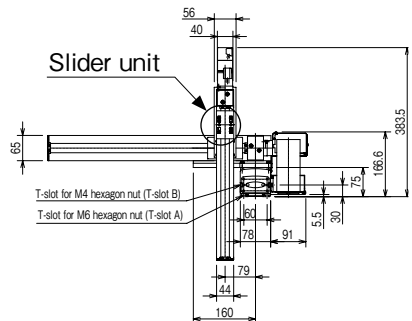
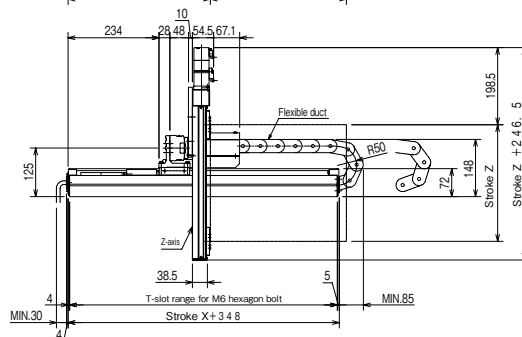
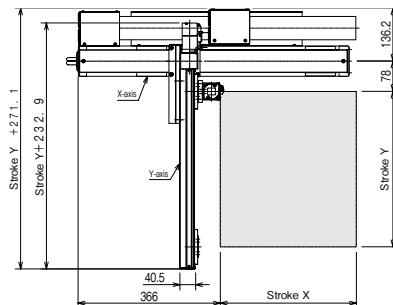
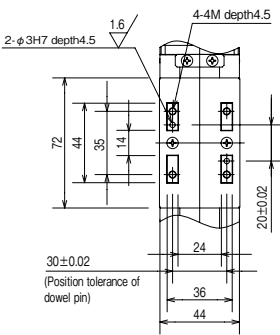

[Set designation]

**BA2 – A1 – A3AR G – 45 30 30 – OF 2 3**

Combined operation R: Right-handed L: Left-handed	Axis 1 stroke 15 : 150mm 95 : 950mm A5 : 1050mm	Axis 2 stroke 05 : 50mm 30 : 300mm	Axis 3 stroke 05 : 50mm 30 : 300mm	Controller 0: None 1: CA20-M10 2: CA10-M00B 3: CA10-M01B	Cable length 3 : 3m 9 : 9m 5 : 5m B : 11m 7 : 7m D : 13m
---	--	--	--	--	---

**Ball screw type**

- X-axis: Ball screw driven  
Side mounted motor
- Y-axis: Ball screw driven  
Motor straight
- Z-axis: Ball screw driven  
Motor straight

[Specifications]

	X-axis	Y-axis	Z-axis
Type of axis	BB10E-U □ -S20N- □ 5	BB07D-ST-M12N- □ □	BB05D-ST-M12B- □ □
Stroke (X-axis in increments of 100 mm, Y- and Z-axes in increments of 50 mm)	150 ~ 1050mm	50 ~ 450mm	50 ~ 300mm
Maximum speed	1200 mm/s (Note 1)	800mm/s	800mm/s
Positioning repeatability	±0.01mm	±0.02mm	±0.02mm
Ball screw lead	20mm	12mm	12mm
Motor output	100W	50W	50 W, with brake
Resolution	0.01mm		

Acceleration/deceleration time when the maximum speed is set: 0.36 sec. or over

Note 1: When the stroke is as given below, the maximum speed differs.

	Stroke (mm)	Maximum speed (mm/s)
X-axis	750	1000
	850	800
	950 ~ 1050	600

Maximum Payload (kg)	Z-axis stroke	Y-axis stroke					
		50mm	100mm	150mm	200mm	250mm	300mm
50,100mm	50,100mm	3.0	3.0	3.0	3.0	1.2	1.2
150,200mm	150,200mm	3.0	3.0	3.0	3.0	1.0	1.0
250,300mm	250,300mm	3.0	3.0	3.0	3.0	0.8	0.8

**R: Right-handed**

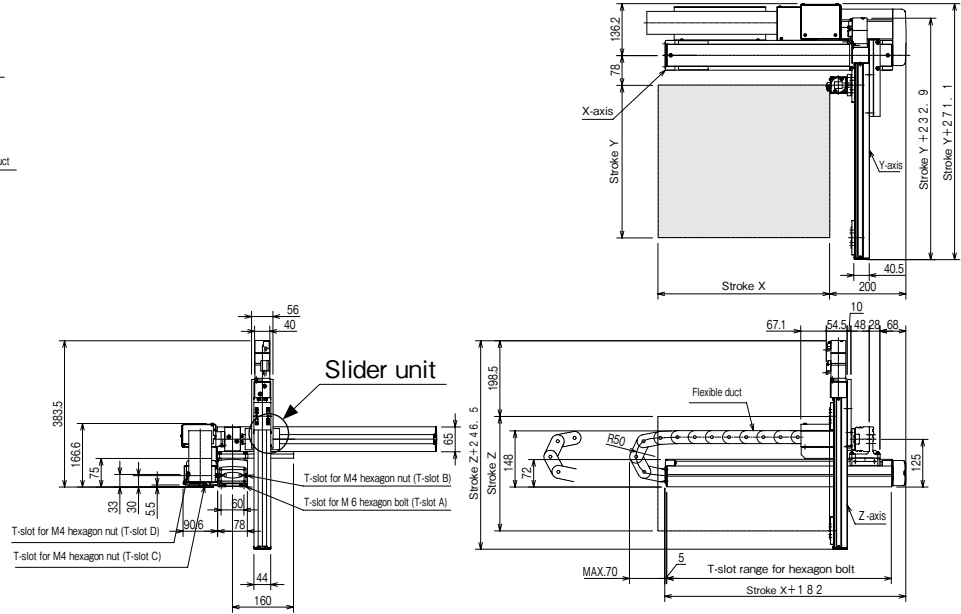
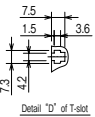
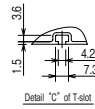
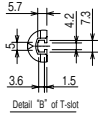
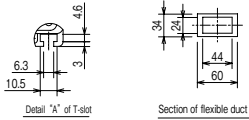

**L: Left-handed**

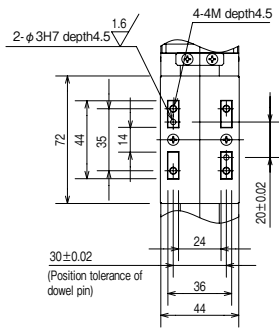

Z-axis slider unit

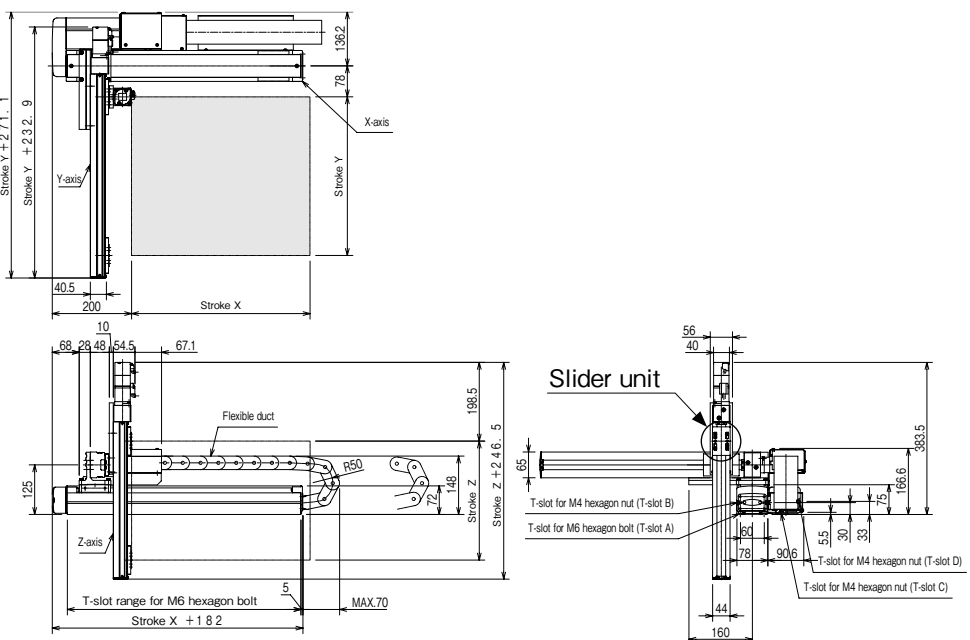

X-Y-Z Flexible-duct Spec., Space-saving type

[Set designation]

**BA2 – A1 – A3C R A – 40 45 30 – OF 2 3**

Combined operation R: Right-handed L: Left-handed	Axis 1 stroke 10 : 100mm 90 : 900mm A0 : 1000mm	Axis 2 stroke 15 : 150mm 45 : 450mm	Axis 3 stroke 05 : 50mm 30 : 300mm	Controller 0: None 1: CA20-M10 2: CA10-M00B 3: CA10-M01B	Cable length 3 : 3m 9 : 9m 5 : 5m B : 11m 7 : 7m D : 13m
---	--	---	--	--	---

Ball screw type

- X-axis: Ball screw driven  
Motor straight
- Y-axis: Ball screw driven  
Motor straight
- Z-axis: Ball screw driven  
Motor straight

[Specifications]

	X-axis	Y-axis	Z-axis
Type of axis	BB10E-ST-M20N-□ 0	BB10E-ST-S20N-□ 5	BB07D-ST-M12B-□ □
Stroke (X- and Y-axes in increments of 100 mm, Z-axis in increments of 50 mm)	100 ~ 1000mm	150 ~ 450mm	50 ~ 300mm
Maximum speed	1200 mm/s (Note 1)	1200mm/s	800mm/s
Positioning repeatability	±0.01mm	±0.01mm	±0.02mm
Ball screw lead	20mm	20mm	12mm
Motor output	100W	100W	50 W, with brake
Resolution	0.01mm		

Note 1: When the stroke is as given below, the maximum speed differs.

	Stroke (mm)	Maximum speed (mm/s)
X-axis	700	1000
	800	800
	900 ~ 1000	600

Acceleration/deceleration time when the maximum speed is set: 0.36 sec. or over

Maximum Payload (kg)		Y-axis stroke			
		150mm	250mm	350mm	450mm
Z-axis stroke	50,100mm	4.0	4.0	3.0	1.5
	150,200mm	4.0	3.0	2.6	1.1
	250,300mm	4.0	3.0	2.0	0.7

R: Right-handed

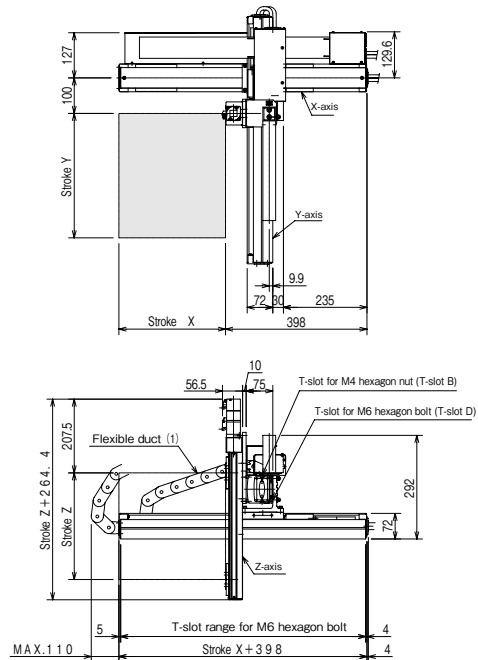
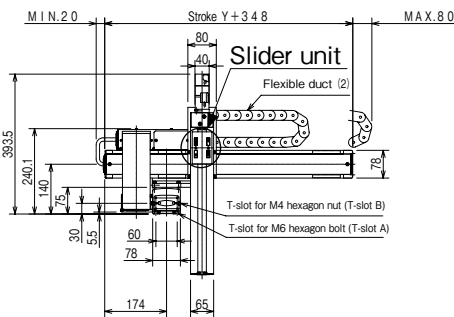
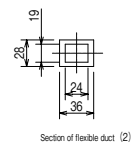
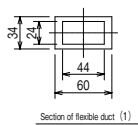
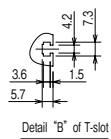
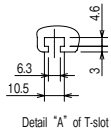

L: Left-handed

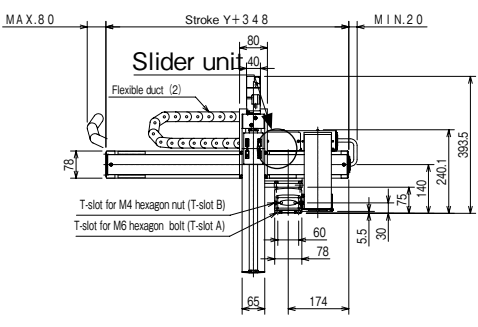
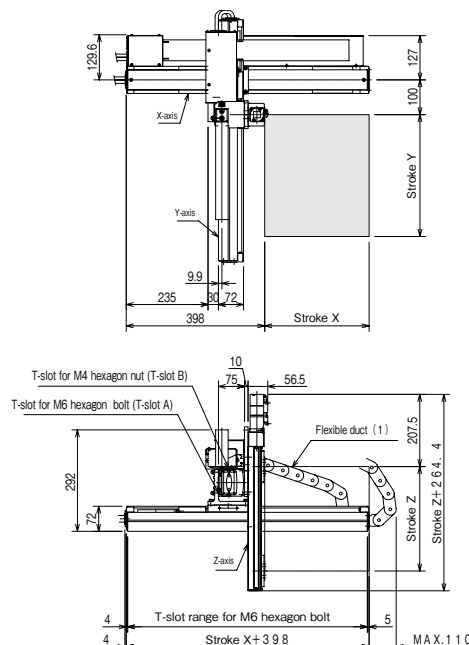
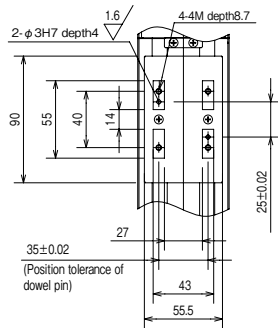

[Set designation]

**BA2 – A1 – A3C R F – 40 45 30 – OF 2 3**

Combined operation R: Right-handed L: Left-handed	Axis 1 stroke 10 : 100mm 90 : 900mm A0 : 1000mm	Axis 2 stroke 15 : 150mm 45 : 450mm	Axis 3 stroke 05 : 50mm 30 : 300mm	Controller 0: None 1: CA20-M10 2: CA10-M00B 3: CA10-M01B	Cable length 3 : 3m 9 : 9m 5 : 5m B : 11m 7 : 7m D : 13m
---	--	---	--	--	---

**Ball screw type**

- X-axis: Ball screw driven  
Side mounted motor
- Y-axis: Ball screw driven  
Motor straight
- Z-axis: Ball screw driven  
Motor straight

[Specifications]

	X-axis	Y-axis	Z-axis
Type of axis	BB10E-U □ -M20N- □ 0	BB10E-U □ -S20N- □ 5	BB07D-ST-M12B- □ □
Stroke (X- and Y-axes in increments of 100 mm, Z-axis in increments of 50 mm)	100 ~ 1000mm	150 ~ 450mm	50 ~ 300mm
Maximum speed	1200 mm/s (Note 1)	1200mm/s	800mm/s
Positioning repeatability	±0.01mm	±0.01mm	±0.02mm
Ball screw lead	20mm	20mm	12mm
Motor output	100W	100W	50 W, with brake
Resolution	0.01mm		

Acceleration/deceleration time when the maximum speed is set: 0.36 sec. or over

Note 1: When the stroke is as given below, the maximum speed differs.

	Stroke (mm)	Maximum speed (mm/s)
X-axis	700	1000
	800	800
	900 ~ 1000	600

Maximum Payload (kg)		Y-axis stroke			
		150mm	250mm	350mm	450mm
Z-axis stroke	50,100mm	4.0	4.0	3.0	1.5
	150,200mm	4.0	3.0	2.6	1.1
	250,300mm	4.0	3.0	2.0	0.7

**R: Right-handed**

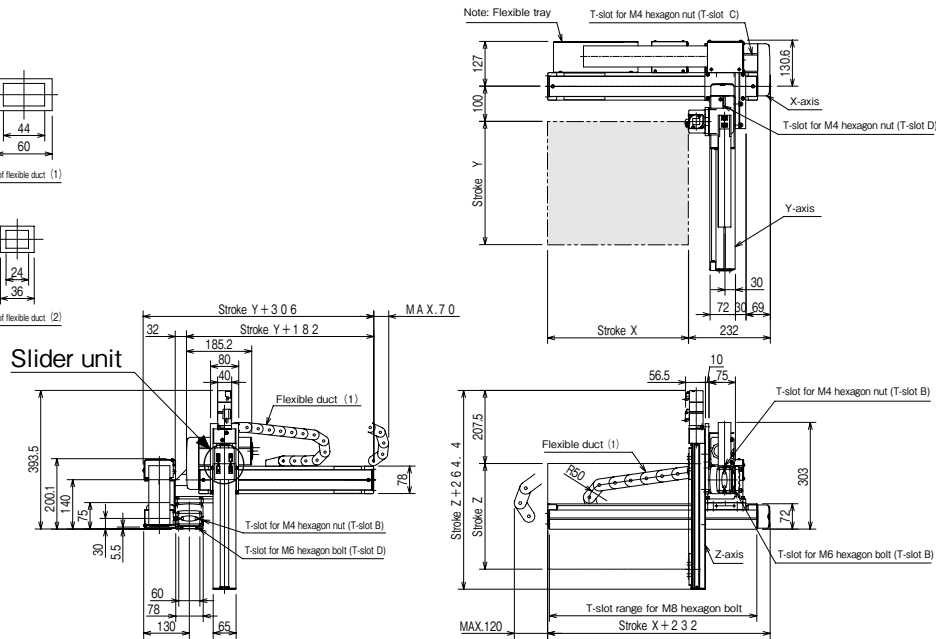
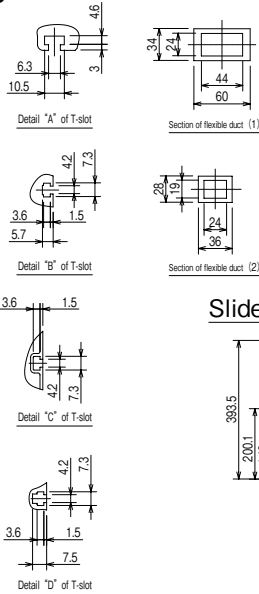

**L: Left-handed**

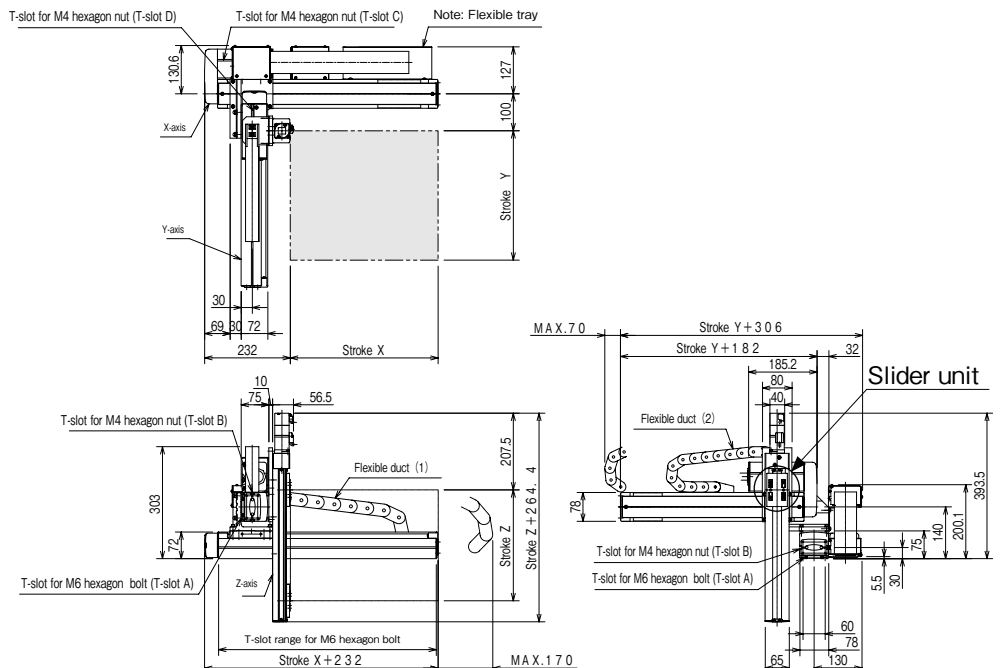
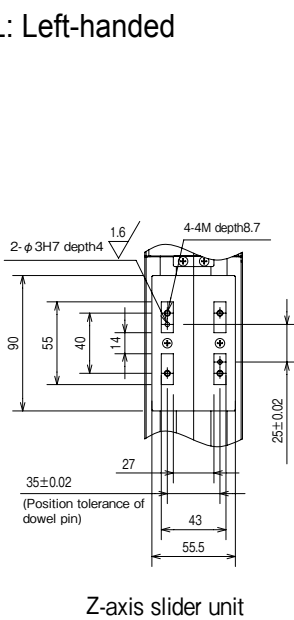



[Set designation]

BA2 – A3 – A3E R A – 45 45 30 – OF 2 3

Combined operation R: Right-handed L: Left-handed	Axis 1 stroke 15 : 150mm 95 : 950mm A5 : 1050mm	Axis 2 stroke 15 : 150mm 65 : 650mm	Axis 3 stroke 05 : 50mm 30 : 300mm	Controller 0: None 1: CA20-M10 2: CA10-M00B 3: CA10-M01B	Cable length 3 : 3m 9 : 9m 5 : 5m B : 11m 7 : 7m D : 13m
---	--	---	--	--	---

Ball screw type

- X-axis: Ball screw driven  
Motor straight
- Y-axis: Ball screw driven  
Motor straight
- Z-axis: Ball screw driven  
Motor straight

[Specifications]

	X-axis	Y-axis	Z-axis
Type of axis	BB30E-ST-M20N-□ 5	BB10E-ST-S20N-□ 5	BB07D-ST-M12B-□ □
Stroke (X- and Y-axes in increments of 100 mm, Z-axis in increments of 50 mm)	150 ~ 1050mm	150 ~ 650mm	50 ~ 300mm
Maximum speed	1200 mm/s (Note 1)	1200mm/s	800mm/s
Positioning repeatability	±0.01mm	±0.01mm	±0.02mm
Ball screw lead	20mm	20mm	12mm
Motor output	200W	100W	100 W, with brake
Resolution	0.01mm		

Note 1: When the stroke is as given below, the maximum speed differs.

	Stroke (mm)	Maximum speed (mm/s)
X-axis	750	1000
	850	800
	950 ~ 1050	600

Acceleration/deceleration time when the maximum speed is set: 0.48 sec. or over

Maximum Payload (kg)	Y-axis stroke					
	150mm	250mm	350mm	450mm	550mm	650mm
Z-axis stroke	50,100mm	4.0	4.0	4.0	4.0	3.5
	150,200mm	4.0	4.0	4.0	4.0	3.1
	250,300mm	4.0	4.0	4.0	4.0	2.7

R: Right-handed

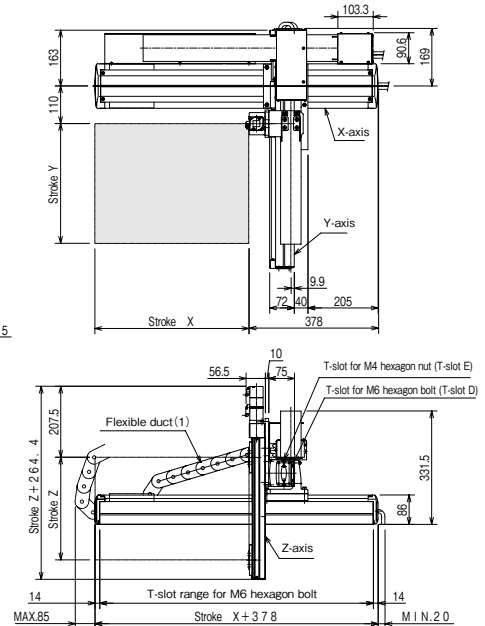
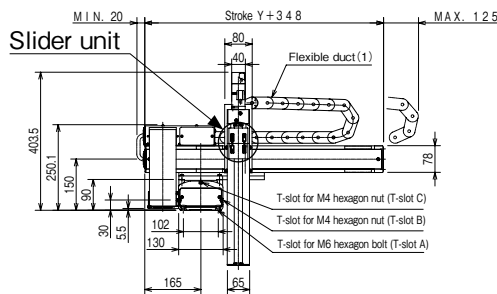
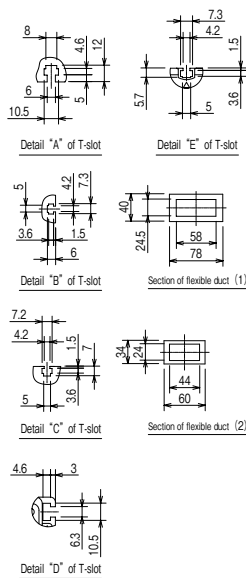

L: Left-handed

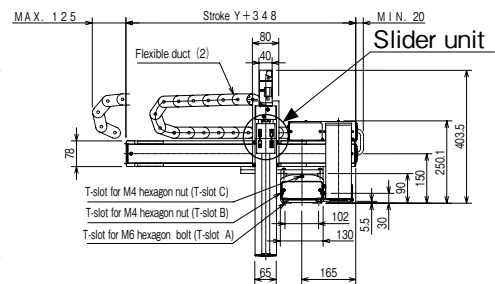
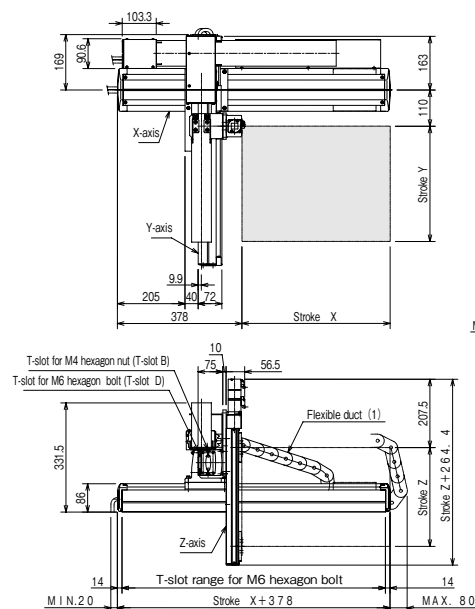
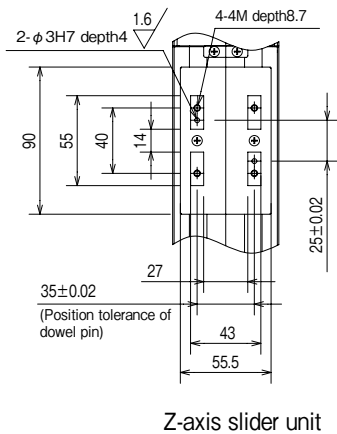

X-Y-Z Flexible-duct Spec.

[Set designation]

**BA2 – A3 – A3E R F – 40 45 30 – OF 2 3**

Combined operation R: Right-handed L: Left-handed	Axis 1 stroke 10 : 100mm 90 : 900mm A0 : 1000mm	Axis 2 stroke 15 : 150mm 65 : 650mm	Axis 3 stroke 05 : 50mm 30 : 300mm	Controller 0: None 1: CA20-M10 2: CA10-M00B 3: CA10-M01B	Cable length 3 : 3m 9 : 9m 5 : 5m B : 11m 7 : 7m D : 13m
---	--	---	--	--	---

**Ball screw type**

- X-axis: Ball screw driven  
Side mounted motor
- Y-axis: Ball screw driven  
Side mounted motor
- Z-axis: Ball screw driven  
Motor straight

[Specifications]

	X-axis	Y-axis	Z-axis
Type of axis	BB30E-U □ -M20N- □ 0	BB10E-U □ -S20N- □ 5	BB07D-ST-M12B- □ □
Stroke (X- and Y-axes in increments of 100 mm, Z-axis in increments of 50 mm)	100 ~ 1000mm	150 ~ 650mm	50 ~ 300mm
Maximum speed	1200 mm/s (Note 1)	1200mm/s	800mm/s
Positioning repeatability	±0.01mm	±0.01mm	±0.02mm
Ball screw lead	20mm	20mm	12mm
Motor output	100W	100W	50 W, with brake
Resolution	0.01mm		

Acceleration/deceleration time when the maximum speed is set: 0.48 sec. or over

Note 1: When the stroke is as given below, the maximum speed differs.

	Stroke (mm)	Maximum speed (mm/s)
X-axis	700	1000
	800	800
	900 ~ 1000	600

Maximum Payload (kg)	Y-axis stroke					
	150mm	250mm	350mm	450mm	550mm	650mm
Z-axis stroke	50,100mm	4.0	4.0	4.0	4.0	3.5
	150,200mm	4.0	4.0	4.0	4.0	3.1
	250,300mm	4.0	4.0	4.0	4.0	2.7

**R: Right-handed**

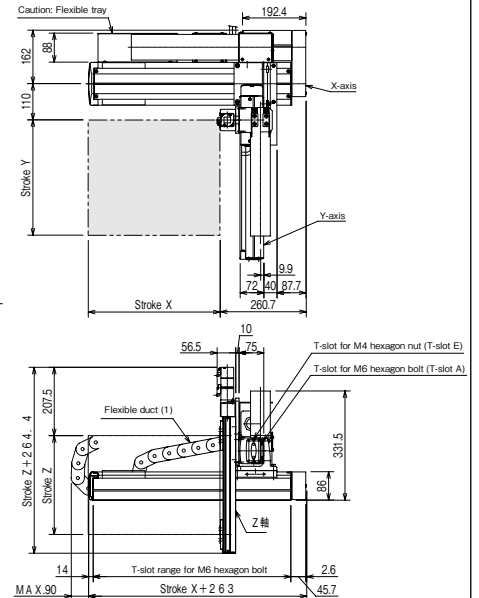
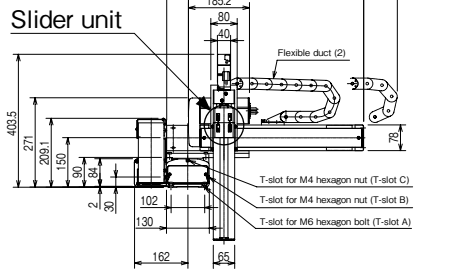
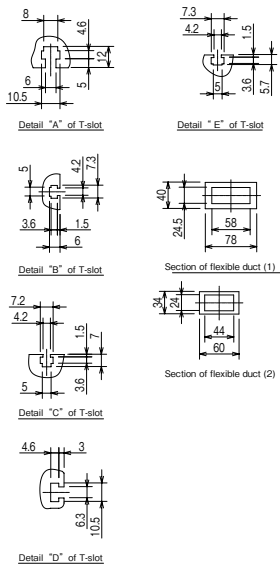

**L: Left-handed**

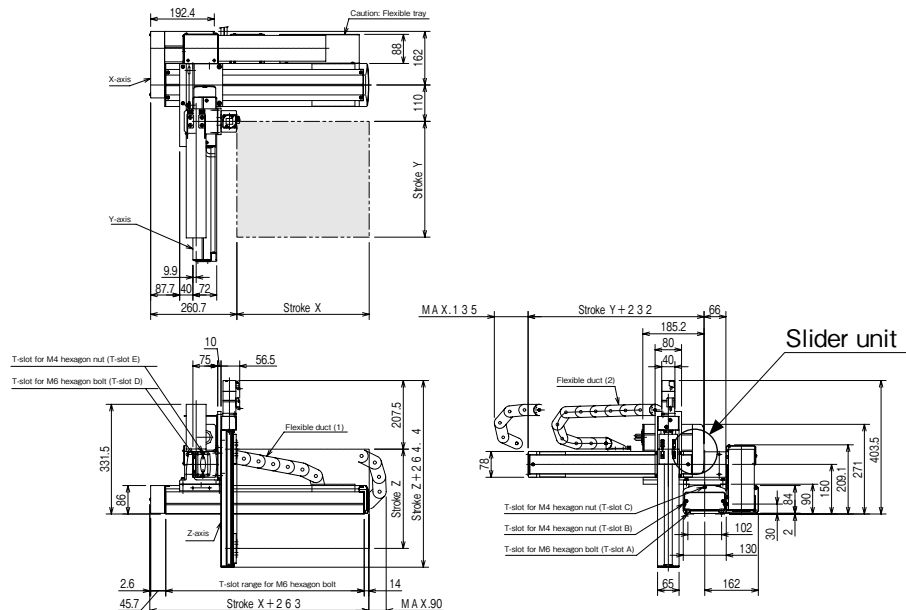
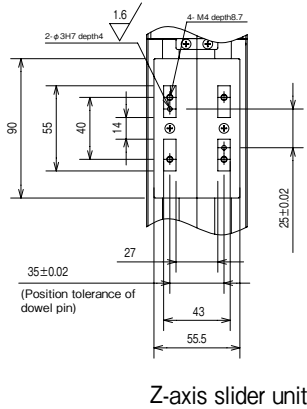

X-Y-Z Flexible-duct Spec., Space-saving type

[Set designation]

**BA2 – A3 – A3GR A – 40 45 30 – OF 2 3**

Combined operation  
R: Right-handed  
L: Left-handed

Axis 1 stroke  
10 : 100mm  
90 : 900mm  
A0 : 1000mm

Axis 2 stroke  
15 : 150mm  
85 : 850mm

Axis 3 stroke  
05 : 50mm  
30 : 300mm

Controller  
0: None  
1: CA20-M10  
2: CA10-M00B  
3: CA10-M01B

ケーブル長  
3 : 3m 9 : 9m  
5 : 5m B : 11m  
7 : 7m D : 13m

**Ball screw type**

X-axis: Ball screw driven  
Motor straight  
Y-axis: Ball screw driven  
Motor straight  
Z-axis: Ball screw driven  
Motor straight

[Specifications]

	X-axis	Y-axis	Z-axis
Type of axis	BB30F-ST-M20N-□ 0	BB10E-ST-S20N-□ 5	BB07D-ST-M12B-□ □
Stroke (X- and Y-axes in increments of 100 mm, Z-axis in increments of 50 mm)	100 ~ 1000mm	150 ~ 850mm	50 ~ 300mm
Maximum speed	1200 mm/s (Note 1)	1200mm/s	800mm/s
Positioning repeatability	±0.01mm	±0.01mm	±0.02mm
Ball screw lead	20mm	20mm	12mm
Motor output	200W	100W	50 W, with brake
Resolution	0.01mm		

Note 1: When the stroke is as given below, the maximum speed differs.

	Stroke (mm)	Maximum speed (mm/s)
X-axis	700	1000
	800	800
	900 ~ 1000	600
Y-axis	750	1000
	850	800

Acceleration/deceleration time when the maximum speed is set: 0.36 sec. or over

Maximum Payload (kg)	Y-axis stroke								
	150mm	250mm	350mm	450mm	550mm	650mm	750mm	850mm	
Z-axis stroke	50,100mm	4.0	4.0	4.0	4.0	4.0	3.9	2.1	0.6
	150,200mm	4.0	4.0	4.0	4.0	4.0	3.6	1.8	0.3
	250,300mm	4.0	4.0	4.0	4.0	4.0	3.3	1.5	—

**R: Right-handed**

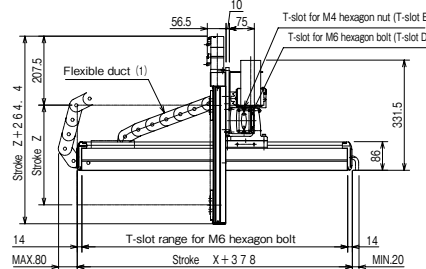
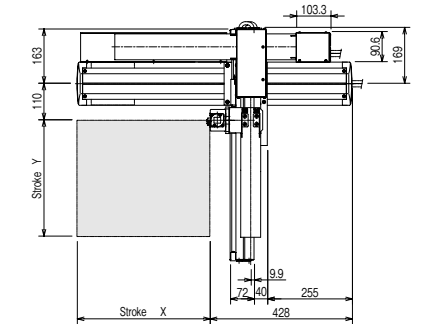
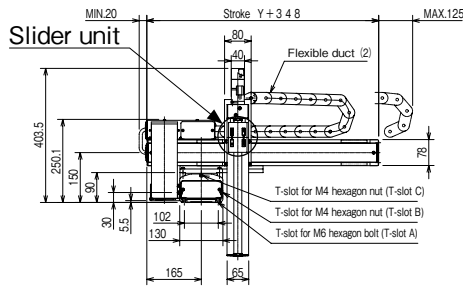
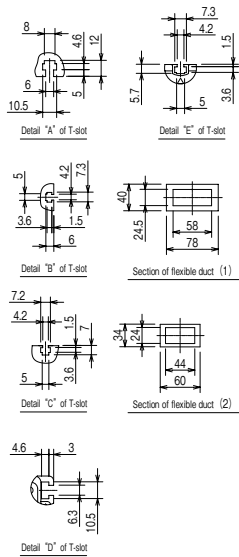

**L: Left-handed**

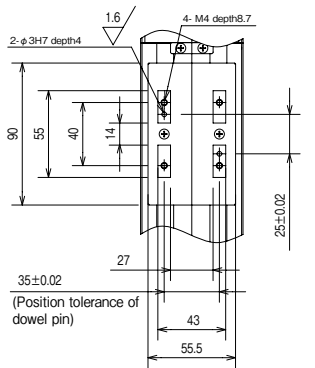

Z-axis slider unit

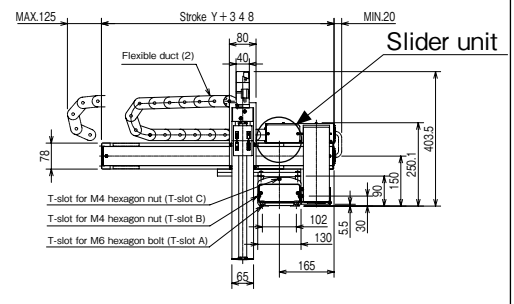
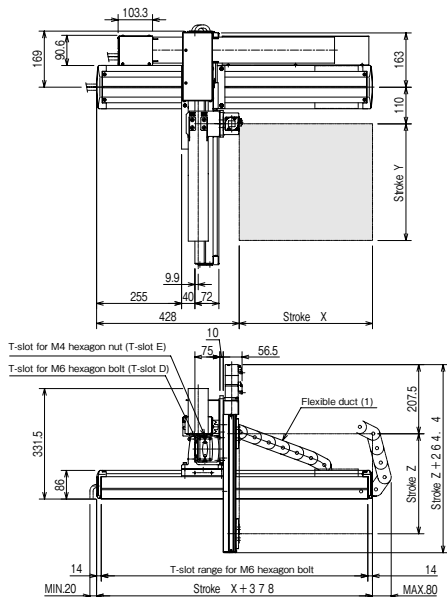

X-Y-Z Flexible-duct Spec.

[Set designation]

BA2 – A3 – A3GR F – 40 45 30 – OF 2 3

Combined operation R: Right-handed L: Left-handed	Axis 1 stroke 10 : 100mm 90 : 900mm A0 : 1000mm	Axis 2 stroke 15 : 150mm 85 : 650mm	Axis 3 stroke 05 : 50mm 30 : 300mm	Controller 0: None 1: CA20-M10 2: CA10-M00B 3: CA10-M01B	Cable length 3 : 3m 9 : 9m 5 : 5m B : 11m 7 : 7m D : 13m
---	--	---	--	--	---

Ball screw type

X-axis: Ball screw driven  
Side mounted motor  
Y-axis: Ball screw driven  
Side mounted motor  
Z-axis: Ball screw driven  
Motor straight

[Specifications]

	X-axis	Y-axis	Z-axis
Type of axis	BB30E-U □ -M20N- □ 0	BB10E-U □ -S20N- □ 5	BB07D-ST-M12B- □ □
Stroke (X- and Y-axes in increments of 100 mm, Z-axis in increments of 50 mm)	100 ~ 1000mm	150 ~ 850mm	50 ~ 300mm
Maximum speed	1200 mm/s (Note 1)	1200mm/s	800mm/s
Positioning repeatability	±0.01mm	±0.01mm	±0.02mm
Ball screw lead	20mm	20mm	12mm
Motor output	100W	100W	50 W, with brake
Resolution	0.01mm		

Note 1: When the stroke is as given below, the maximum speed differs.

	Stroke (mm)	Maximum speed (mm/s)
X-axis	700	1000
	800	800
	900 ~ 1000	600
Y-axis	750	1000
	850	800

Acceleration/deceleration time when the maximum speed is set: 0.36 sec. or over

Maximum Payload (kg)		Y-axis stroke							
		150mm	250mm	350mm	450mm	550mm	650mm	750mm	850mm
Z-axis stroke	50,100mm	4.0	4.0	4.0	4.0	4.0	3.9	2.1	0.6
	150,200mm	4.0	4.0	4.0	4.0	4.0	3.6	1.8	0.3
	250,300mm	4.0	4.0	4.0	4.0	4.0	3.3	1.5	—

R: Right-handed

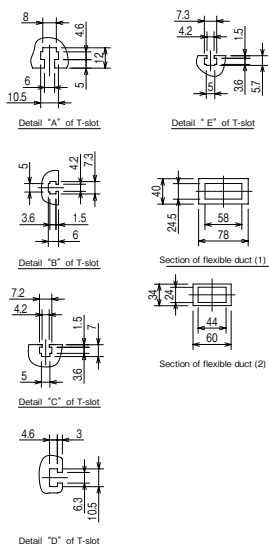

Slider unit

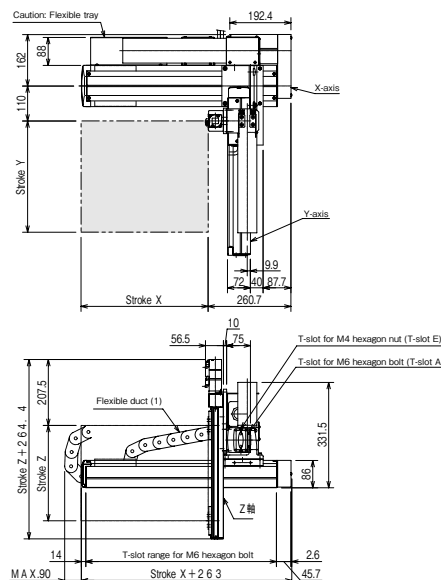
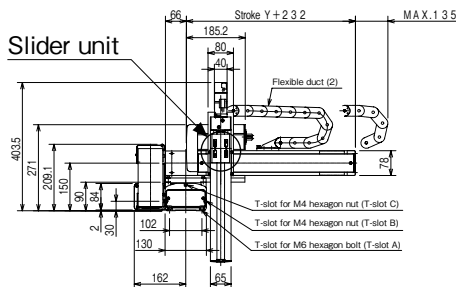

L: Left-handed

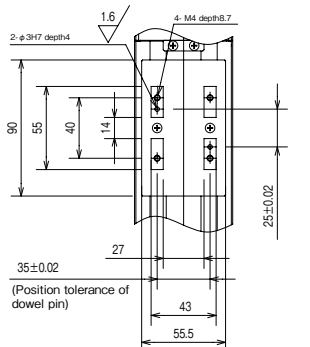

Z-axis slider unit

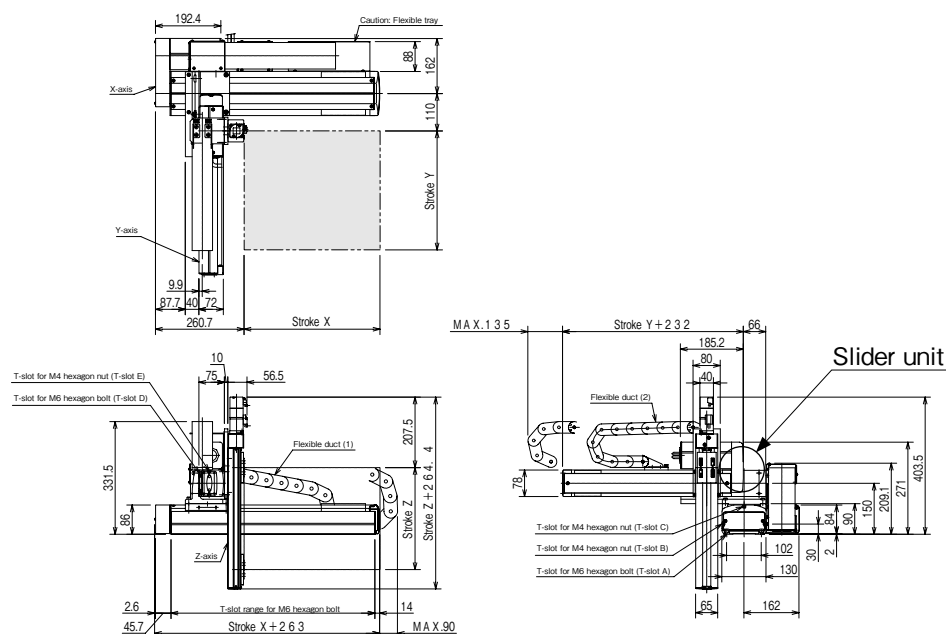

X-Y-Z Flexible-duct Spec., Space-saving type

[Set designation]

BA2 – A3 – A3A R B – 45 40 35 – OF 2 3

Combined operation R: Right-handed L: Left-handed	Axis 1 stroke 15 : 150mm 95 : 950mm A5 : 1050mm	Axis 2 stroke 10 : 100mm 50 : 500mm	Axis 3 stroke 15 : 150mm 35 : 350mm	Controller 0: None 1: CA20-M10 2: CA10-M00B 3: CA10-M01B	Cable length 3 : 3m 9 : 9m 5 : 5m B : 11m 7 : 7m D : 13m
---	--	---	---	--	---

Ball screw type

- X-axis: Ball screw driven  
Motor straight
- Y-axis: Ball screw driven  
Motor straight
- Z-axis: Ball screw driven  
Side mounted motor

[Specifications]

	X-axis	Y-axis	Z-axis
Type of axis	BB30E-ST-M20N-□ 5	BB10E-ST-M20N-□ 0	BB10E-U □ -S10B-□ 5
Stroke	150 ~ 1050mm	100 ~ 500mm	150 ~ 350mm
Maximum speed	1200 mm/s (Note 1)	1200mm/s	300mm/s
Positioning repeatability	±0.01mm		
Ball screw lead	20mm	20mm	10mm
Motor output	100W	100W	100 W, with brake
Resolution	0.01mm		

Note 1: When the stroke is as given below, the maximum speed differs.

X-axis	Stroke (mm)	Maximum speed (mm/s)
	750	1000
	850	800
	950 ~ 1050	600

Acceleration/deceleration time when the maximum speed is set: 0.48 sec. or

Maximum Payload (kg)	Y-axis stroke					
	100mm	200mm	300mm	400mm	500mm	
Z-axis stroke	150mm	7.0	6.0	5.0	4.0	2.0
	250mm	6.0	5.0	4.0	4.0	2.0
	350mm	5.0	5.0	3.0	3.0	1.0

R: Right-handed

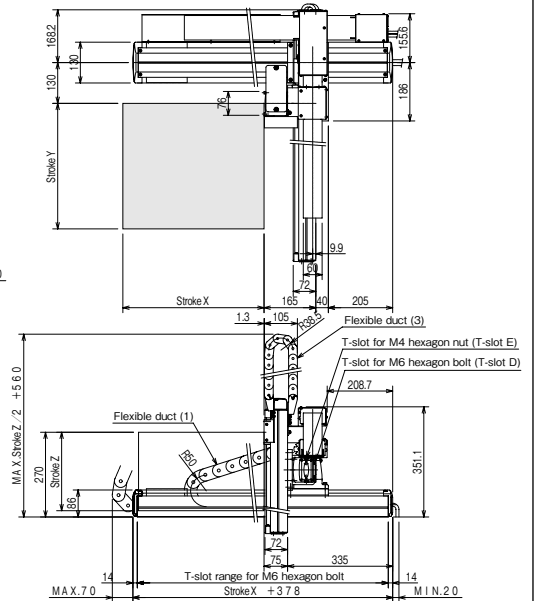
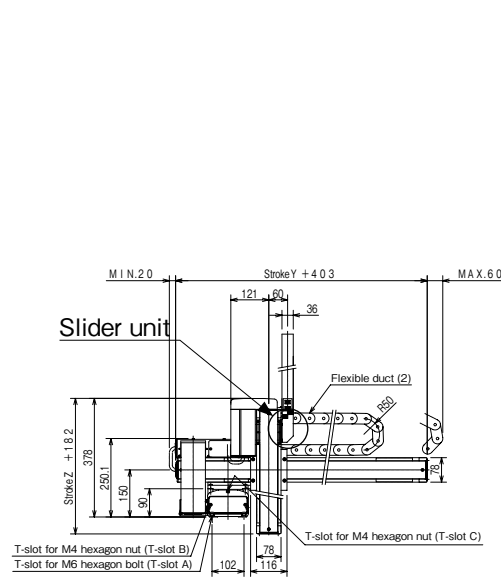
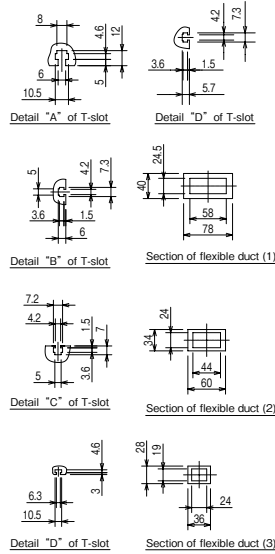

L: Left-handed

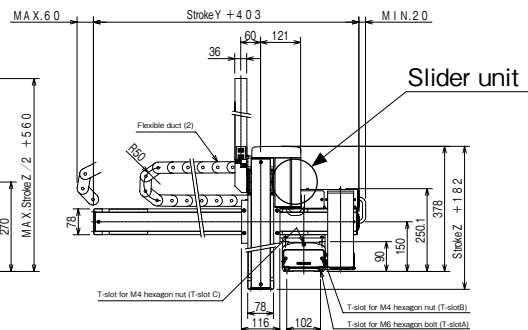
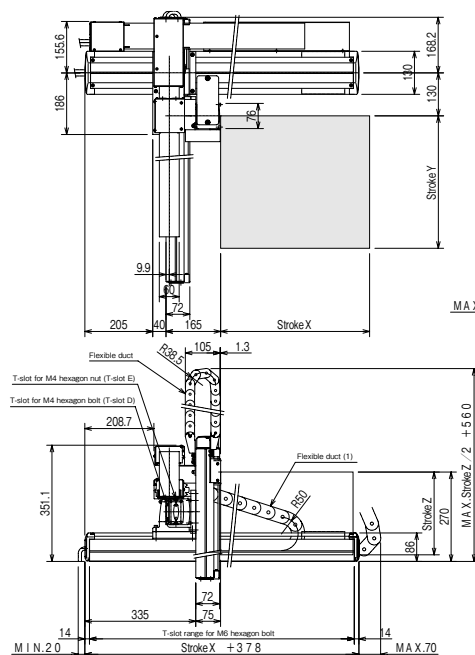
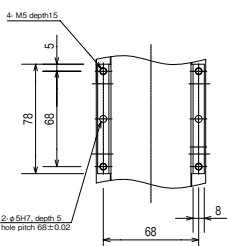

X-Y-Z Flexible-duct Spec.

[Set designation]

**BA2 – A3 – A3A R B – 45 40 35 – OT 2 3**

Combined operation R: Right-handed L: Left-handed	Axis 1 stroke 15 : 150mm 95 : 950mm A5 : 1050mm	Axis 2 stroke 10 : 100mm 50 : 500mm	Axis 3 stroke 15 : 150mm 35 : 350mm	Controller 0: None 1: CA20-M10 2: CA10-M00B 3: CA10-M01B	Cable length 3 : 3m 9 : 9m 5 : 5m B : 11m 7 : 7m D : 13m
---	--	---	---	--	---

**Ball screw type**

- X-axis: Ball screw driven  
Motor straight
- Y-axis: Ball screw driven  
Motor straight
- Z-axis: Ball screw driven  
Side mounted motor

**[Specifications]**

	X-axis	Y-axis	Z-axis
Type of axis	BB30E-ST-M20N-□ 5	BB10E-ST-M20N-□ 0	BB10E-U □ -S10B-□ 5
Stroke	150 ~ 1050mm	100 ~ 500mm	150 ~ 350mm
Maximum speed	1200 mm/s (Note 1)	1200mm/s	300mm/s
Positioning repeatability	±0.01mm		
Ball screw lead	20mm	20mm	10mm
Motor output	100W	100W	100 W, with brake
Resolution	0.01mm		

Note 1: When the stroke is as given below, the maximum speed differs.

	Stroke (mm)	Maximum speed (mm/s)
X-axis	750	1000
	850	800
	950 ~ 1050	600

Acceleration/deceleration time when the maximum speed is set: 0.48 sec. or over

Maximum Payload (kg)	Y-axis stroke					
	100mm	200mm	300mm	400mm	500mm	
Z-axis stroke	150mm	7.0	6.0	5.0	4.0	2.0
	250mm	6.0	5.0	4.0	4.0	2.0
	350mm	5.0	5.0	3.0	3.0	1.0

**R: Right-handed**

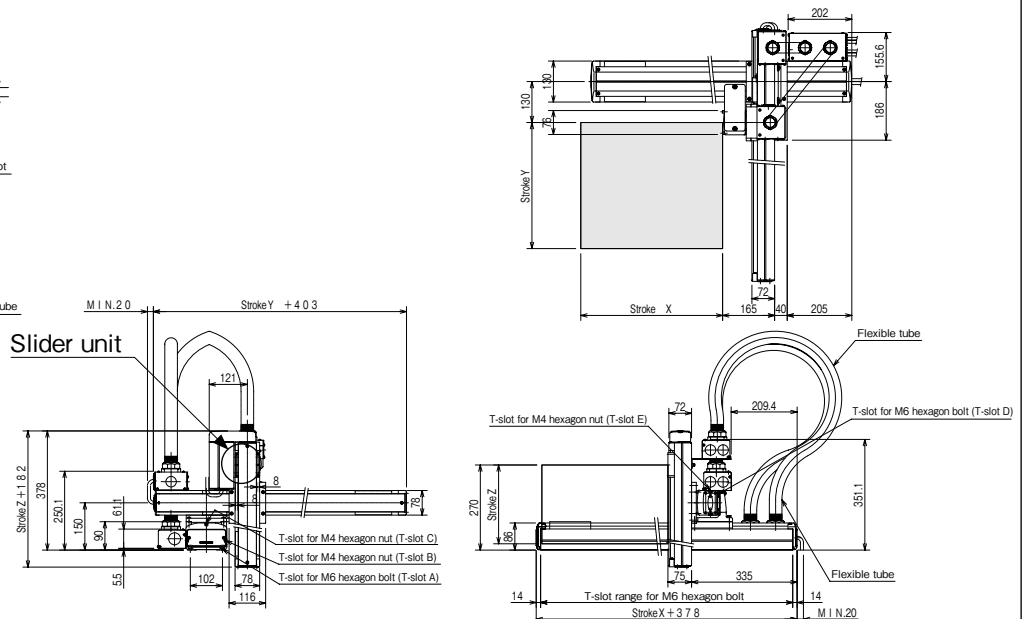
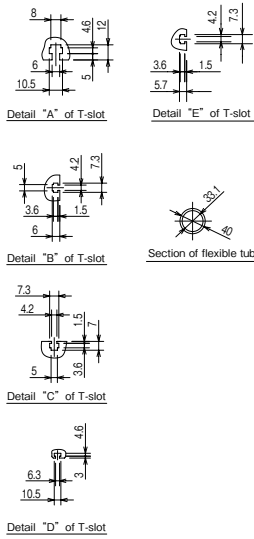

**L: Left-handed**

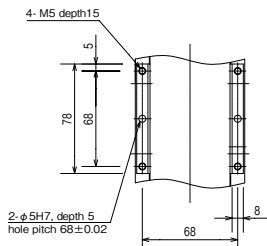

**Z-axis slider unit**

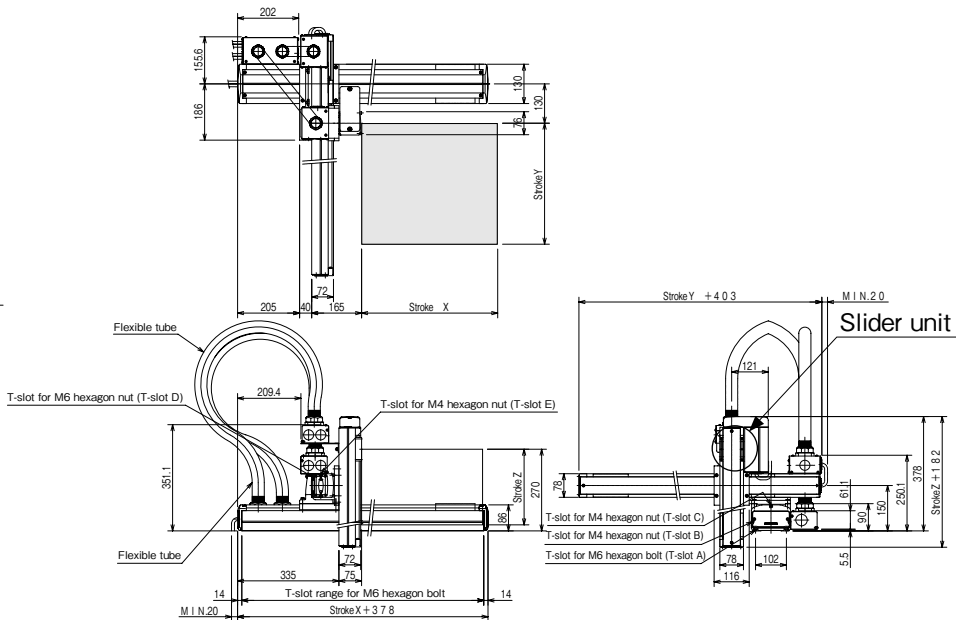

X-Y-Z Flexible-tube Spec.

[Set designation]

**BA2 – A3 – A3A R E – 40 40 35 – OF 2 3**

Combined operation R: Right-handed L: Left-handed	Axis 1 stroke 10 : 100mm 90 : 900mm A0 : 1000mm	Axis 2 stroke 10 : 100mm 50 : 500mm	Axis 3 stroke 15 : 150mm 35 : 350mm	Controller 0: None 1: CA20-M10 2: CA10-M00B 3: CA10-M01B	Cable length 3 : 3m 9 : 9m 5 : 5m B : 11m 7 : 7m D : 13m
---	--	---	---	--	---

**Ball screw type**

- X-axis: Ball screw driven  
Side mounted motor
- Y-axis: Ball screw driven  
Side mounted motor
- Z-axis: Ball screw driven  
Side mounted motor

[Specifications]

	X-axis	Y-axis	Z-axis
Type of axis	BB30E-U □ -M20N- □ 0	BB10E-U □ -M20N- □ 0	BB10E-U □ -S10B- □ 5
Stroke	100 ~ 1000mm	100 ~ 500mm	150 ~ 350mm
Maximum speed	1200 mm/s (Note 1)	1200mm/s	300mm/s
Positioning repeatability	±0.01mm		
Ball screw lead	20mm	20mm	10mm
Motor output	100W	100W	100 W, with brake
Resolution	0.01mm		

Acceleration/deceleration time when the maximum speed is set: 0.48 sec. or over

Note 1: When the stroke is as given below, the maximum speed differs.

	Stroke (mm)	Maximum speed (mm/s)
X-axis	700	1000
	800	800
	900 ~ 1000	600

Maximum Payload (kg)	Y-axis stroke					
	100mm	200mm	300mm	400mm	500mm	
Z-axis stroke	150mm	7.0	6.0	5.0	4.0	2.0
	250mm	6.0	5.0	4.0	4.0	2.0
	350mm	5.0	5.0	3.0	3.0	1.0

**R: Right-handed**

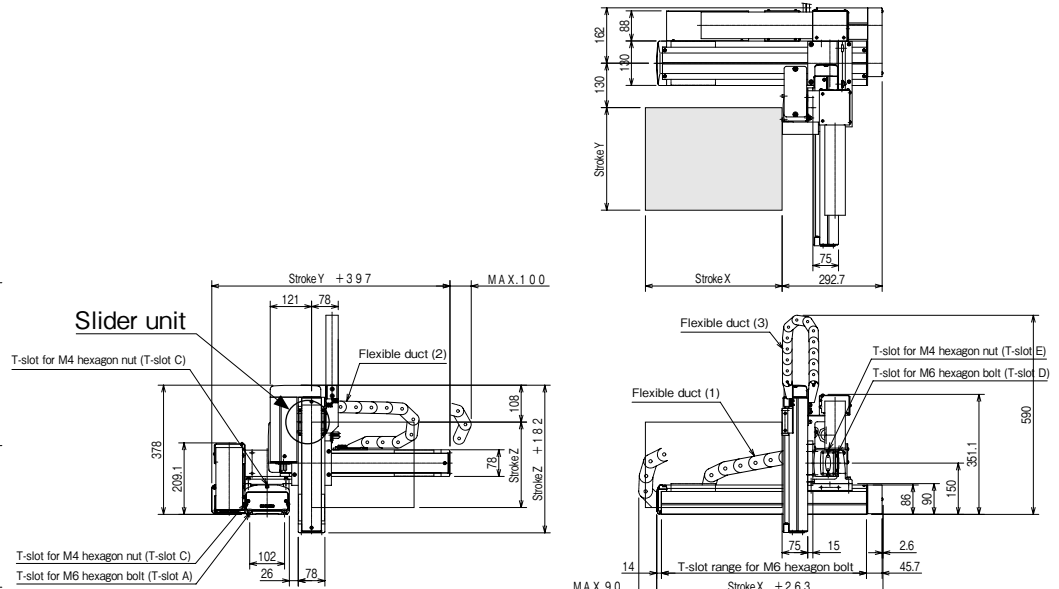
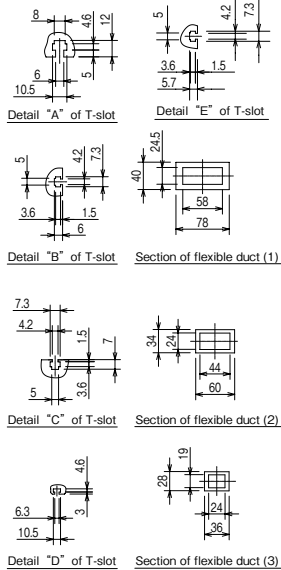

**L: Left-handed**

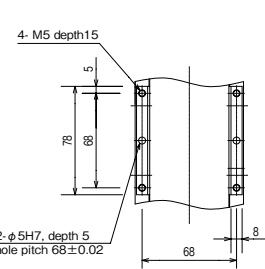

**Z-axis slider unit**

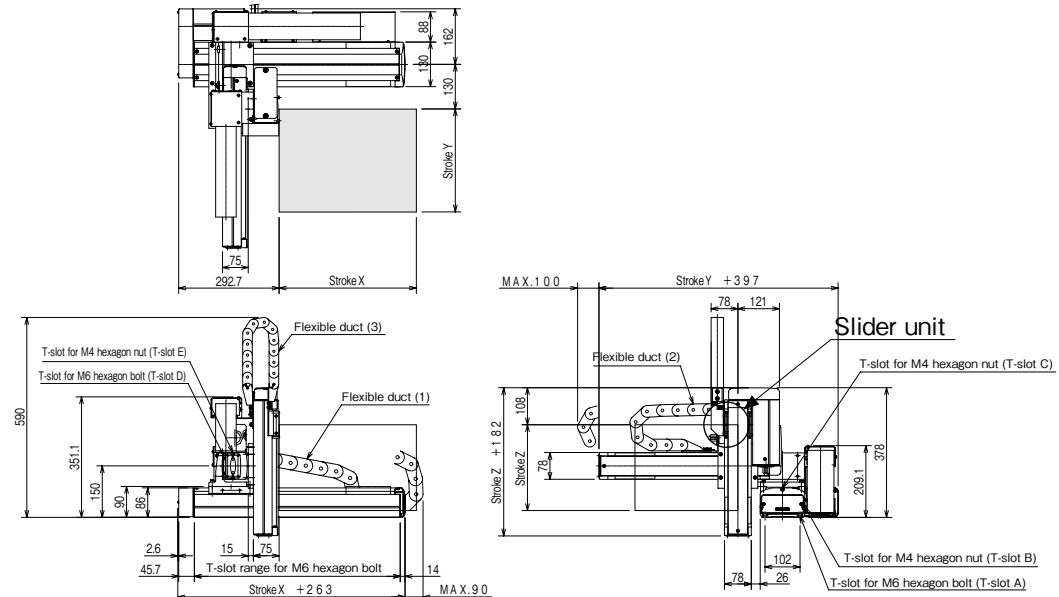

X-Y-Z Flexible-duct Spec., Space-saving type

[Set designation]

**BA2 - A3 - A3A R E - 40 40 35 - OT 2 3**

Combined operation	Axis 1 stroke	Axis 2 stroke	Axis 3 stroke	Controller	Cable length
R: Right-handed	10 : 100mm	10 : 100mm	15 : 150mm	0: None	3 : 3m 9 : 9m
L: Left-handed	90 : 900mm A0 : 1000mm	50 : 500mm	35 : 350mm	1: CA20-M10 2: CA10-M00B 3: CA10-M01B	5 : 5m B : 11m 7 : 7m D : 13m

**Ball screw type**

- X-axis: Ball screw driven  
Side mounted motor
- Y-axis: Ball screw driven  
Side mounted motor
- Z-axis: Ball screw driven  
Side mounted motor

[Specifications]

	X-axis	Y-axis	Z-axis
Type of axis	BB30E-U □ -M20N- □ 0	BB10E-U □ -M20N- □ 0	BB10E-U □ -S10B- □ 5
Stroke	100 ~ 1000mm	100 ~ 500mm	150 ~ 350mm
Maximum speed	1200 mm/s (Note 1)	1200mm/s	600mm/s
Positioning repeatability	±0.01mm		
Ball screw lead	20mm	20mm	10mm
Motor output	100W	100W	100 W, with brake
Resolution	0.01mm		

Note 1: When the stroke is as given below, the maximum speed differs.

	Stroke (mm)	Maximum speed (mm/s)
X-axis	700	1000
	800	800
	900 ~ 1000	600

Acceleration/deceleration time when the maximum speed is set: 0.48 sec. or over

Maximum Payload (kg)	Y-axis stroke					
	100mm	200mm	300mm	400mm	500mm	
Z-axis stroke	150mm	7.0	6.0	5.0	4.0	2.0
	250mm	6.0	5.0	4.0	4.0	2.0
	350mm	5.0	5.0	3.0	3.0	1.0

**R: Right-handed**

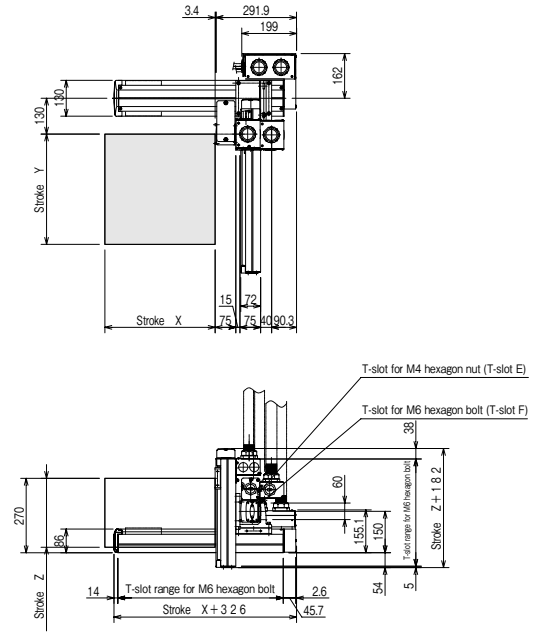
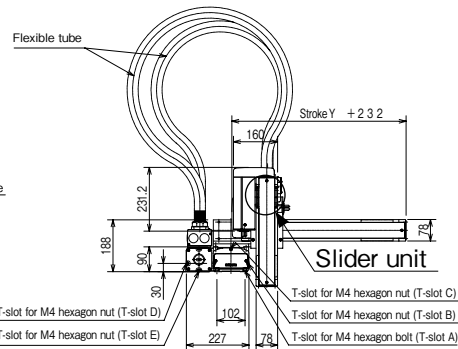
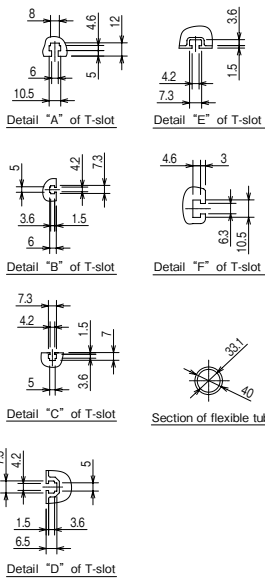

**L: Left-handed**

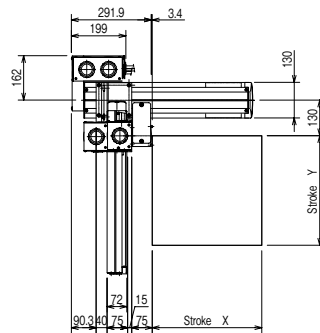
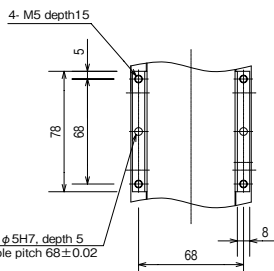

**Z-axis slider unit**

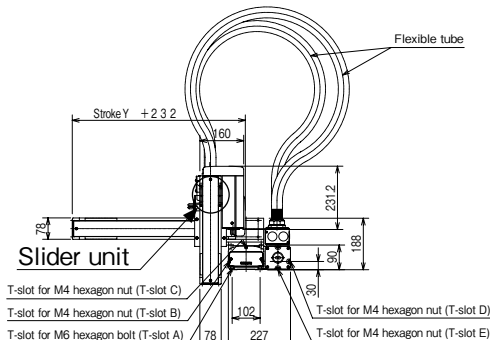
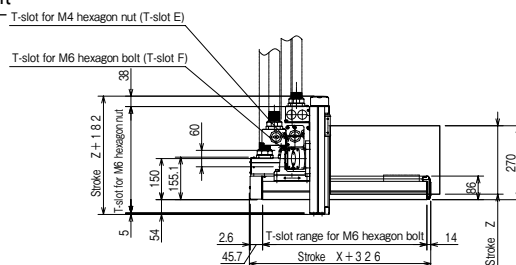

X-Y-Z Flexible-tube Spec., Space-saving type



[Set designation]

**BA2 – A3 – A3B R B – 40 40 35 – OF2 3**

**Ball screw type**

- X-axis: Ball screw driven  
Motor straight
- Y-axis: Ball screw driven  
Motor straight
- Z-axis: Ball screw driven  
Side mounted motor

Combined operation R: Right-handed L: Left-handed	Axis 1 stroke 10 : 100mm 90 : 900mm A0 : 1000mm	Axis 2 stroke 10 : 100mm 50 : 500mm	Axis 3 stroke 15 : 150mm 35 : 350mm	Controller 0: None 1: CA20-M10 2: CA10-M00B 3: CA10-M01B	Cable length 3 : 3m 9 : 9m 5 : 5m B : 11m 7 : 7m D : 13m
---	--	---	---	--	---

[Specifications]

	X-axis	Y-axis	Z-axis
Type of axis	BB30F-ST-M20N-□ 0	BB10E-ST-M20N-□ 0	BB10E-U □ -S10B-□ 5
Stroke	100 ~ 1000mm	100 ~ 500mm	150 ~ 350mm
Maximum speed	1200 mm/s (Note 1)	1200mm/s	600mm/s
Positioning repeatability	±0.01mm		
Ball screw lead	20mm	20mm	10mm
Motor output	200W	100W	100 W, with brake
Resolution	0.01mm		

Note 1: When the stroke is as given below, the maximum speed differs.

	Stroke (mm)	Maximum speed (mm/s)
X-axis	700	1000
	800	800
	900 ~ 1000	600

Acceleration/deceleration time when the maximum speed is set: 0.36 sec. or over

Maximum Payload (kg)	Y-axis stroke				
	100mm	200mm	300mm	400mm	500mm
Z-axis stroke	150mm	7.0	7.0	7.0	2.0
	250mm	7.0	7.0	6.0	1.0
	350mm	6.0	6.0	6.0	1.0

R: Right-handed

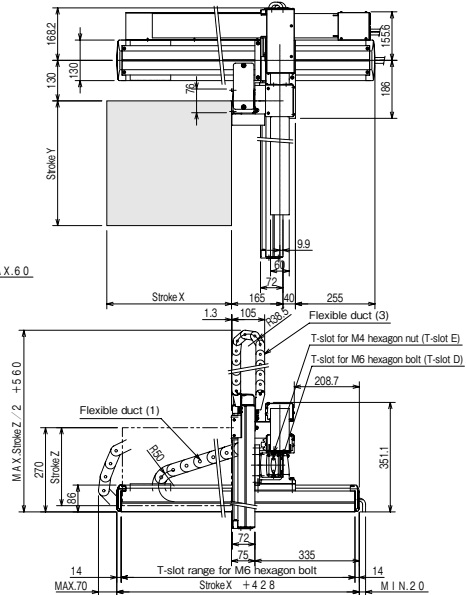
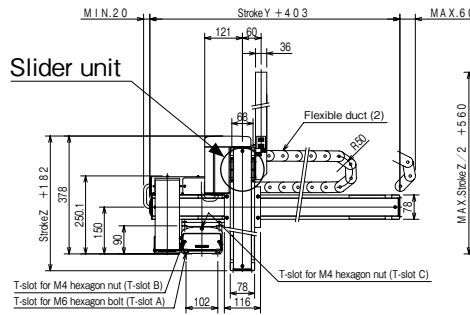
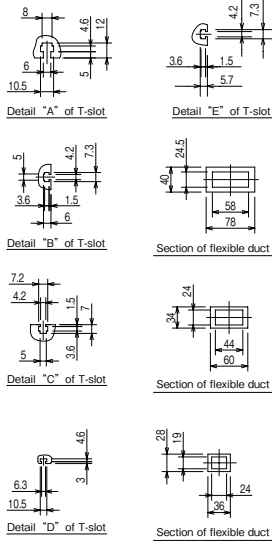

L: Left-handed

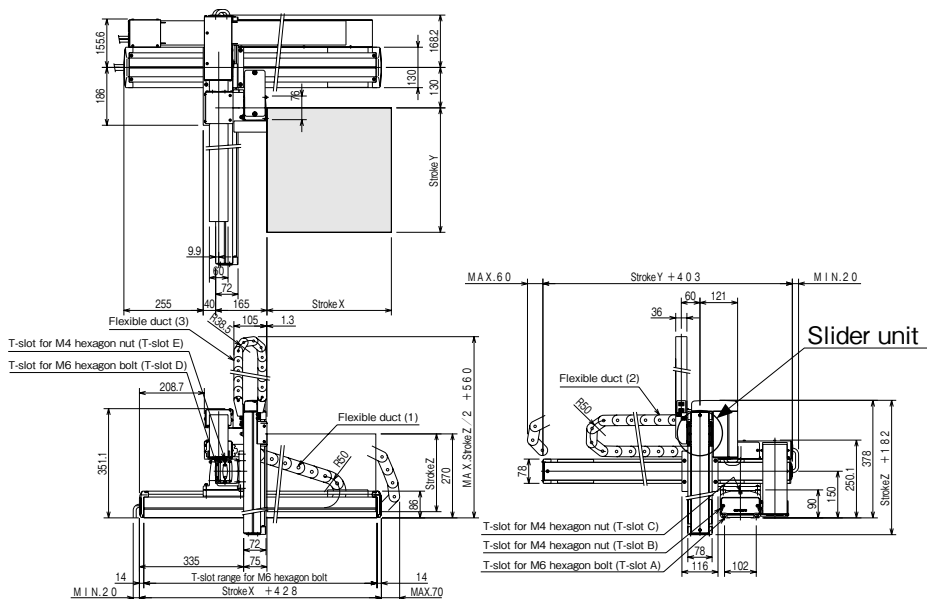
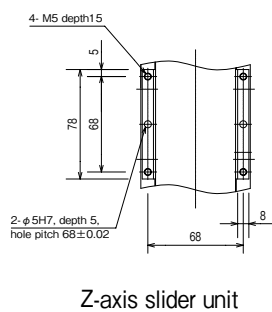

X-Y-Z Flexible-duct Spec.

[Set designation]

**BA2 – A3 – A3B R B – 40 40 35 – OT2 3**

Combined operation R: Right-handed L: Left-handed	Axis 1 stroke 10 : 100mm 90 : 900mm A0 : 1000mm	Axis 2 stroke 10 : 100mm 50 : 500mm	Axis 3 stroke 15 : 150mm 35 : 350mm	Controller 0: None 1: CA20-M10 2: CA10-M00B 3: CA10-M01B	Cable length 3 : 3m 9 : 9m 5 : 5m B : 11m 7 : 7m D : 13m
---	--	---	---	--	---

**Ball screw type**

- X-axis: Ball screw driven  
Motor straight
- Y-axis: Ball screw driven  
Motor straight
- Z-axis: Ball screw driven  
Side mounted motor

[Specifications]

	X-axis	Y-axis	Z-axis
Type of axis	BB30F-ST-M20N-□0	BB10E-ST-M20N-□0	BB10E-U□-S10B-□5
Stroke	100 ~ 1000mm	100 ~ 500mm	150 ~ 350mm
Maximum speed	1200 mm/s (Note 1)	1200mm/s	600mm/s
Positioning repeatability	±0.01mm		
Ball screw lead	20mm	20mm	10mm
Motor output	200W	100W	100 W, with brake
Resolution	0.01mm		

Note 1: When the stroke is as given below, the maximum speed differs.

	Stroke (mm)	Maximum speed (mm/s)
X-axis	700	1000
	800	800
	900 ~ 1000	600

Acceleration/deceleration time when the maximum speed is set: 0.36 sec. or over

Maximum Payload (kg)	Y-axis stroke					
	100mm	200mm	300mm	400mm	500mm	
Z-axis stroke	150mm	7.0	7.0	7.0	4.0	2.0
	250mm	7.0	7.0	6.0	4.0	1.0
	350mm	6.0	6.0	6.0	3.0	1.0

**R: Right-handed**

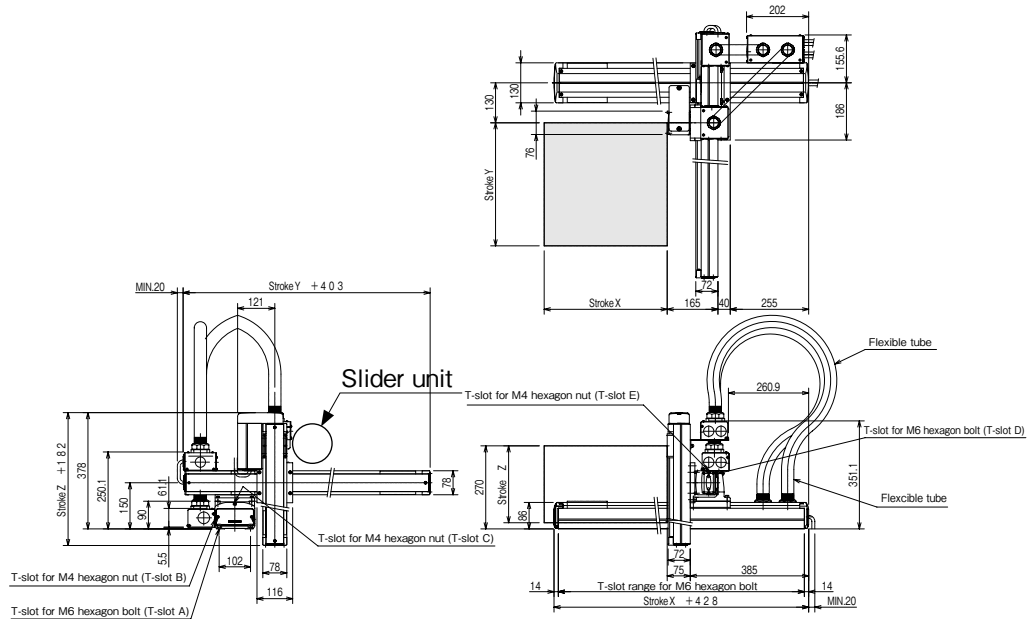
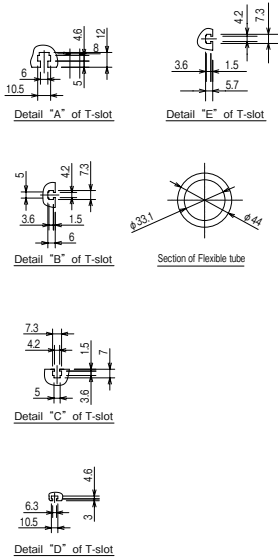

**L: Left-handed**

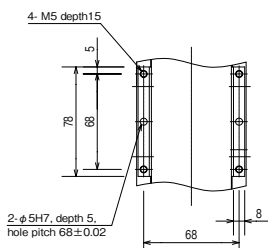

Z-axis slider unit

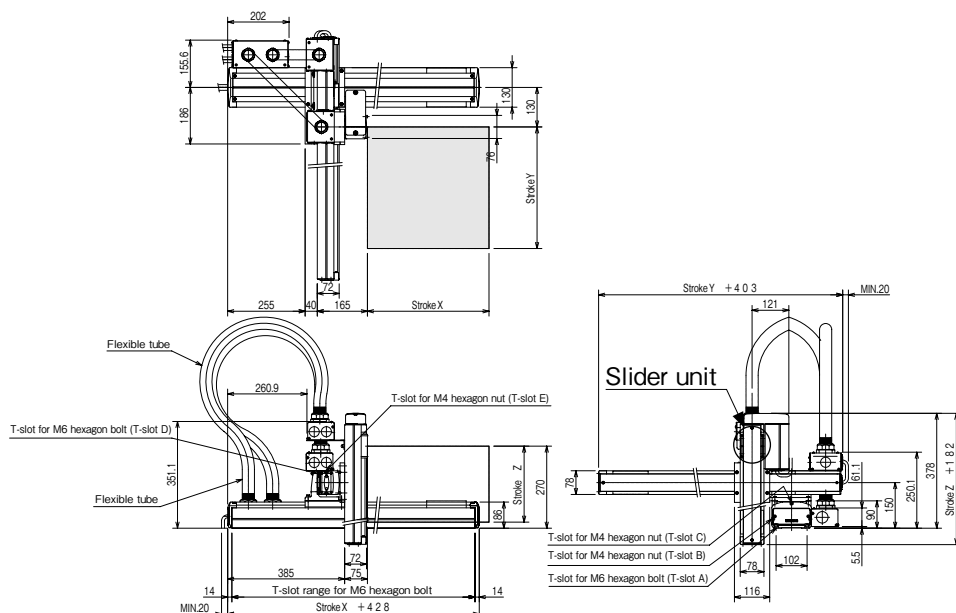

[Set designation]

BA2 - A3 - A3B R E - 40 40 35 - OF 2 3

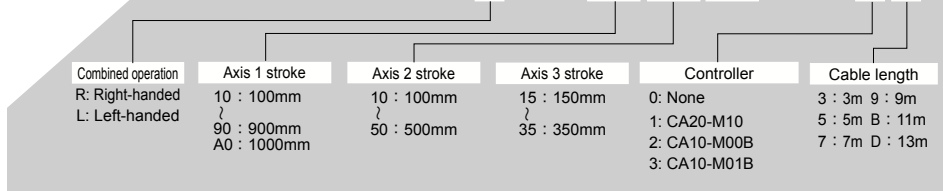

Ball screw type

- X-axis: Ball screw driven  
Side mounted motor
- Y-axis: Ball screw driven  
Side mounted motor
- Z-axis: Ball screw driven  
Side mounted motor

[Specifications]

	X-axis	Y-axis	Z-axis
Type of axis	BB30F-U □ -M20N- □ 0	BB10E-U □ -M20N- □ 0	BB10E-U □ -S10B- □ 5
Stroke	100 ~ 1000mm	100 ~ 500mm	150 ~ 350mm
Maximum speed	1200 mm/s (Note 1)	1200mm/s	600mm/s
Positioning repeatability	±0.01mm		
Ball screw lead	20mm	20mm	10mm
Motor output	200W	100W	100 W, with brake
Resolution	0.01mm		

Note 1: When the stroke is as given below, the maximum speed differs.

	Stroke (mm)	Maximum speed (mm/s)
X-axis	700	1000
	800	800
	900 ~ 1000	600

Acceleration/deceleration time when the maximum speed is set: 0.36 sec. or over

Maximum Payload (kg)	Y-axis stroke					
	100mm	200mm	300mm	400mm	500mm	
Z-axis stroke	150mm	7.0	7.0	7.0	4.0	2.0
	250mm	7.0	7.0	6.0	4.0	1.0
	350mm	6.0	6.0	6.0	3.0	1.0

R: Right-handed

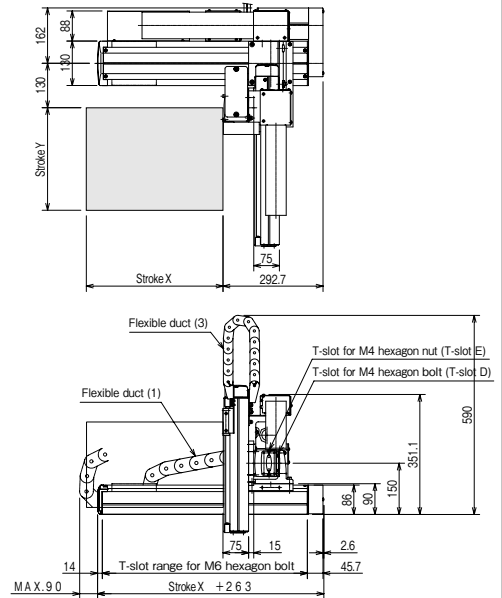
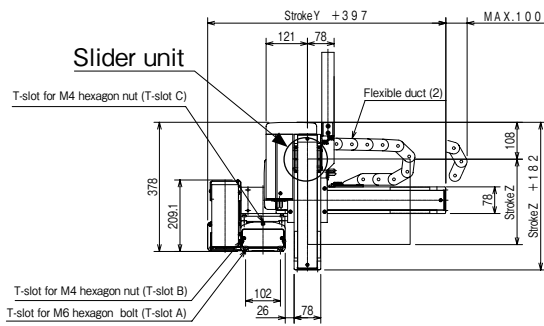
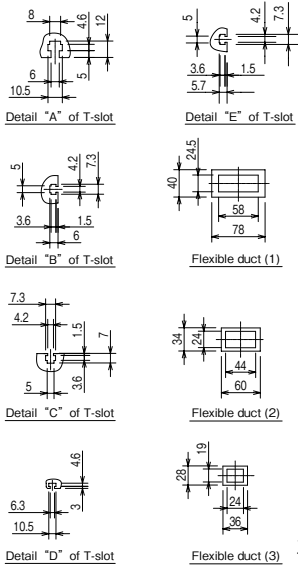

L: Left-handed

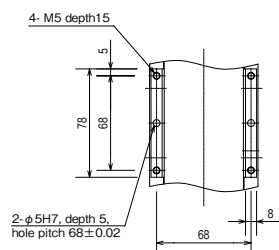

Z-axis slider unit

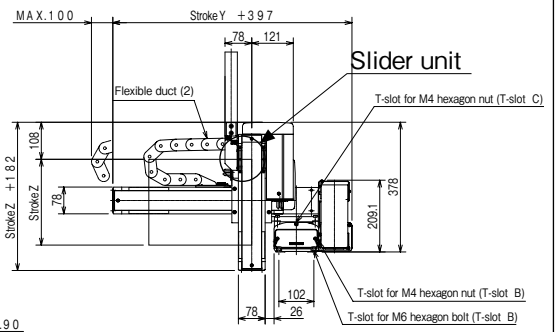
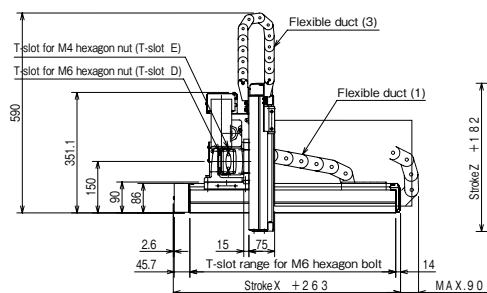
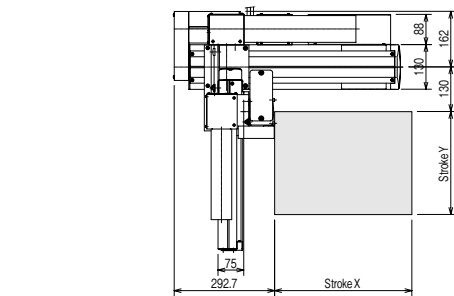

X-Y-Z Flexible-duct Spec., Space-saving type

[Set designation]

**BA2 - A3 - A3B R E - 40 40 35 - OT 2 3**

Combined operation R: Right-handed L: Left-handed	Axis 1 stroke 10 : 100mm 90 : 900mm A0 : 1000mm	Axis 2 stroke 10 : 100mm 50 : 500mm	Axis 3 stroke 15 : 150mm 35 : 350mm	Controller 0: None 1: CA20-M10 2: CA10-M00B 3: CA10-M01B	Cable length 3 : 3m 9 : 9m 5 : 5m B : 11m 7 : 7m D : 13m
---	--	---	---	--	---

**Ball screw type**

- X-axis: Ball screw driven  
Side mounted motor
- Y-axis: Ball screw driven  
Side mounted motor
- Z-axis: Ball screw driven  
Side mounted motor

[Specifications]

	X-axis	Y-axis	Z-axis
Type of axis	BB30F-U □ -M20N- □ 0	BB10E-U □ -M20N- □ 0	BB10E-U □ -S10B- □ 5
Stroke	100 ~ 1000mm	100 ~ 500mm	150 ~ 350mm
Maximum speed	1200 mm/s (Note 1)	1200mm/s	600mm/s
Positioning repeatability	±0.01mm		
Ball screw lead	20mm	20mm	10mm
Motor output	200W	100W	100 W, with brake
Resolution	0.01mm		

Note 1: When the stroke is as given below, the maximum speed differs.

	Stroke (mm)	Maximum speed (mm/s)
X-axis	700	1000
	800	800
	900 ~ 1000	600

Acceleration/deceleration time when the maximum speed is set: 0.36 sec. or over

Maximum Payload (kg)	Z-axis stroke	Y-axis stroke				
		100mm	200mm	300mm	400mm	500mm
150mm	150mm	7.0	7.0	7.0	4.0	2.0
	250mm	7.0	7.0	6.0	4.0	1.0
	350mm	6.0	6.0	6.0	3.0	1.0

**R: Right-handed**

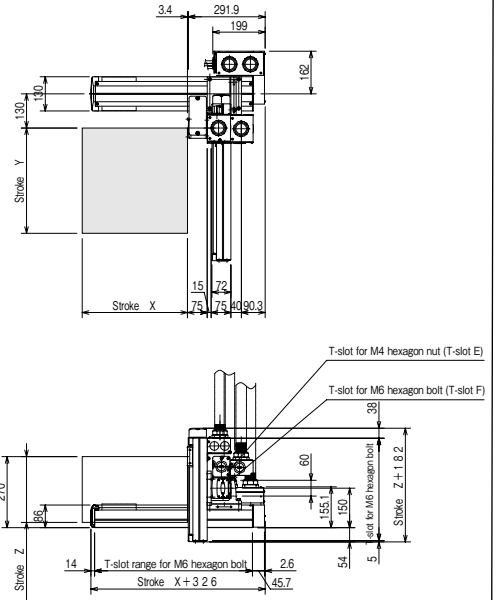
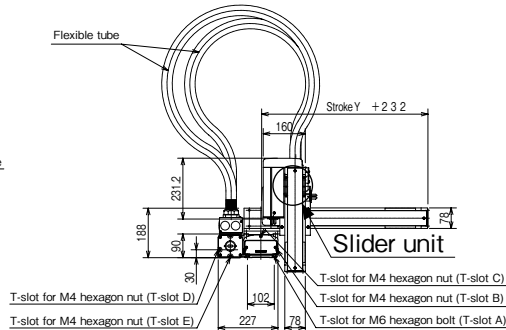
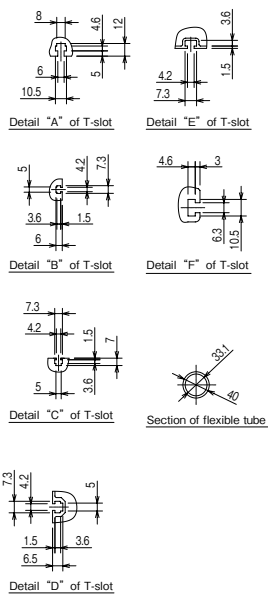

**L: Left-handed**

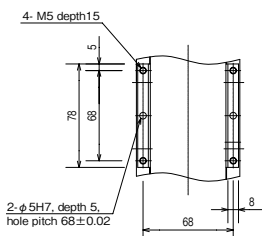

**Z-axis slider unit**

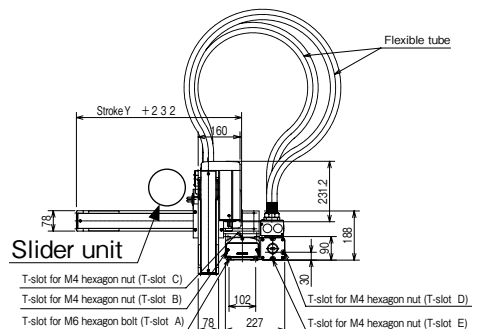
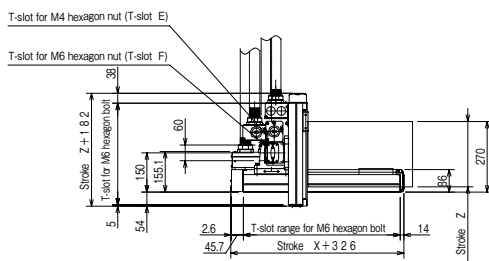

X-Y-Z Flexible-tube Spec., Space-saving type

[Set designation]

BA2 – A5 – A3A R A – 40 45 30 – OF 2 3

Combined operation	Axis 1 stroke	Axis 2 stroke	Axis 3 stroke	Controller	Cable length
R: Right-handed	20 : 200mm	15 : 150mm	10 : 100mm	0: None	3 : 3m 9 : 9m
L: Left-handed	90 : 900mm A0 : 1000mm F0 : 1500mm	65 : 650mm A5 : 1050mm	30 : 300mm	1: CA20-M10 2: CA10-M00B 3: CA10-M01B	5 : 5m B : 11m 7 : 7m D : 13m

**Ball screw type**

- X-axis: Ball screw driven  
Motor straight
- Y-axis: Ball screw driven  
Motor straight
- Z-axis: Ball screw driven  
Motor straight

Note 1: When the stroke is as given below, the maximum speed differs.

	Stroke (mm)	Maximum speed (mm/s)
X-axis	700 ~ 800	1100
	900 ~ 1000	1000
	1100 ~ 1200	700
	1300	500
	1400	400
Y-axis	1500	300
	750	1000
	850	800
	950 ~ 1050	600

[Specifications]

	X-axis	Y-axis	Z-axis
Type of axis	BB50F-ST-M20N-□ 0	BB30E-ST-M20N-□ 5	BB10E-ST-M05B-□ 0
Stroke (in increments of 100 mm)	200 ~ 1500mm	150 ~ 1050mm	100 ~ 300mm
Maximum speed	1200 mm/s (Note 1)	1200 mm/s (Note 1)	300mm/s
Positioning repeatability	±0.01mm		
Ball screw lead	20mm	20mm	5mm
Motor output	200W	100W	100 W, with brake
Resolution	0.01mm		

Acceleration/deceleration time when the maximum speed is set: 0.36 sec. or over

Maximum Payload (kg)	Z-axis stroke	Y-axis stroke									
		150mm	250mm	350mm	450mm	550mm	650mm	750mm	850mm	950mm	1050mm
100mm	100mm	11.0	11.0	11.0	11.0	11.0	11.0	11.0	10.0	8.0	5.0
	200mm	10.0	10.0	10.0	10.0	10.0	10.0	10.0	10.0	7.0	4.0
	300mm	9.0	9.0	9.0	9.0	9.0	9.0	9.0	9.0	6.0	4.0

R: Right-handed

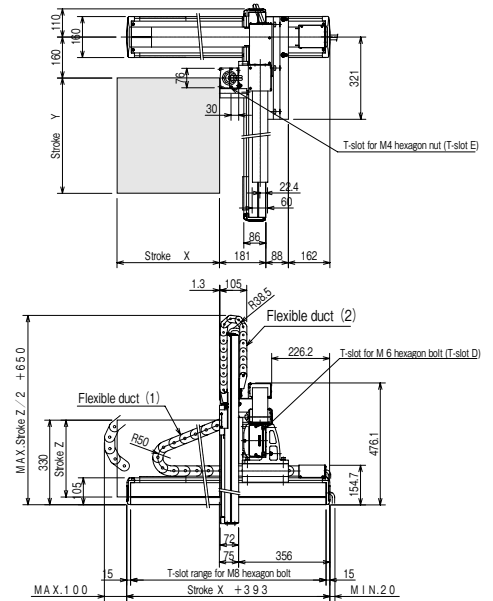
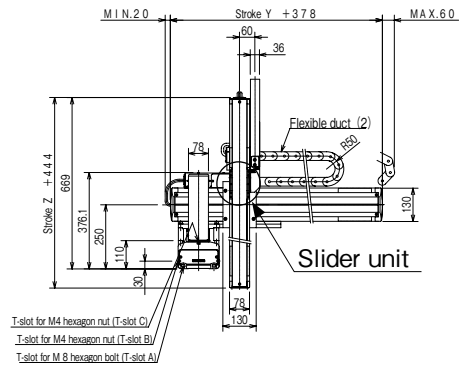
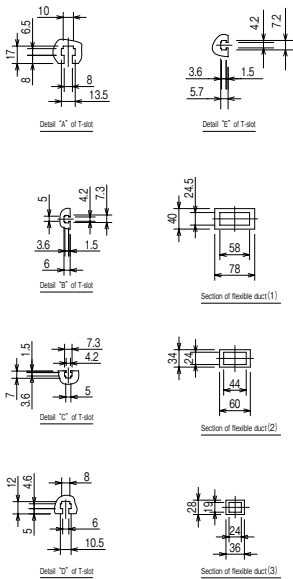

L: Left-handed

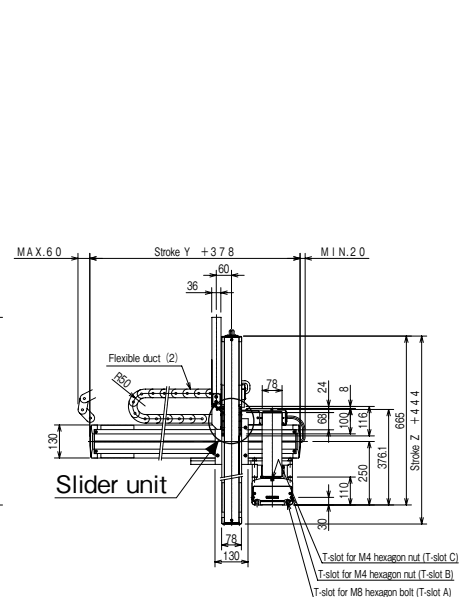
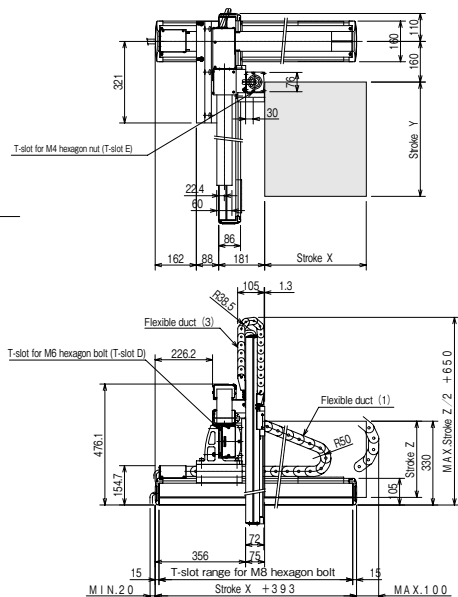
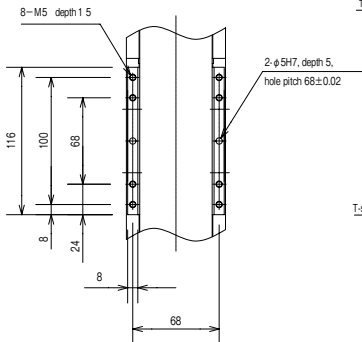

X-Y-Z Flexible-duct Spec.

[Set designation]

**BA2 – A5 – A3A R A – 40 45 30 – OT 2 3**

Combined operation	Axis 1 stroke	Axis 2 stroke	Axis 3 stroke	Controller	Cable length
R: Right-handed	20 : 200mm	15 : 150mm	10 : 100mm	0: None	3 : 3m 9 : 9m
L: Left-handed	90 : 900mm	65 : 650mm	30 : 300mm	1: CA20-M10	5 : 5m B : 11m
	A0 : 1000mm	A5 : 1050mm		2: CA10-M00B	7 : 7m D : 13m
	F0 : 1500mm			3: CA10-M01B	

**Ball screw type**

- X-axis: Ball screw driven  
Motor straight
- Y-axis: Ball screw driven  
Motor straight
- Z-axis: Ball screw driven  
Motor straight

Note 1: When the stroke is as given below, the maximum speed differs.

	Stroke (mm)	Maximum speed (mm/s)
X-axis	700 ~ 800	1100
	900 ~ 1000	1000
	1100 ~ 1200	700
	1300	500
	1400	400
Y-axis	1500	300
	750	1000
	850	800
	950 ~ 1050	600

[Specifications]

	X-axis	Y-axis	Z-axis
Type of axis	BB50F-ST-M20N-□ 0	BB30E-ST-M20N-□ 5	BB10E-ST-M05B-□ 0
Stroke (in increments of 100 mm)	200 ~ 1500mm	150 ~ 1050mm	100 ~ 300mm
Maximum speed	1200 mm/s (Note 1)	1200 mm/s (Note 1)	300mm/s
Positioning repeatability	±0.01mm		
Ball screw lead	20mm	20mm	5mm
Motor output	200W	100W	100 W, with brake
Resolution	0.01mm		

Acceleration/deceleration time when the maximum speed is set: 0.36 sec. or over

Maximum Payload (kg)	Z-axis stroke	Y-axis stroke									
		150mm	250mm	350mm	450mm	550mm	650mm	750mm	850mm	950mm	1050mm
100mm	100mm	11.0	11.0	11.0	11.0	11.0	11.0	11.0	10.0	8.0	5.0
	200mm	10.0	10.0	10.0	10.0	10.0	10.0	10.0	10.0	7.0	4.0
	300mm	9.0	9.0	9.0	9.0	9.0	9.0	9.0	9.0	6.0	4.0

**R: Right-handed**

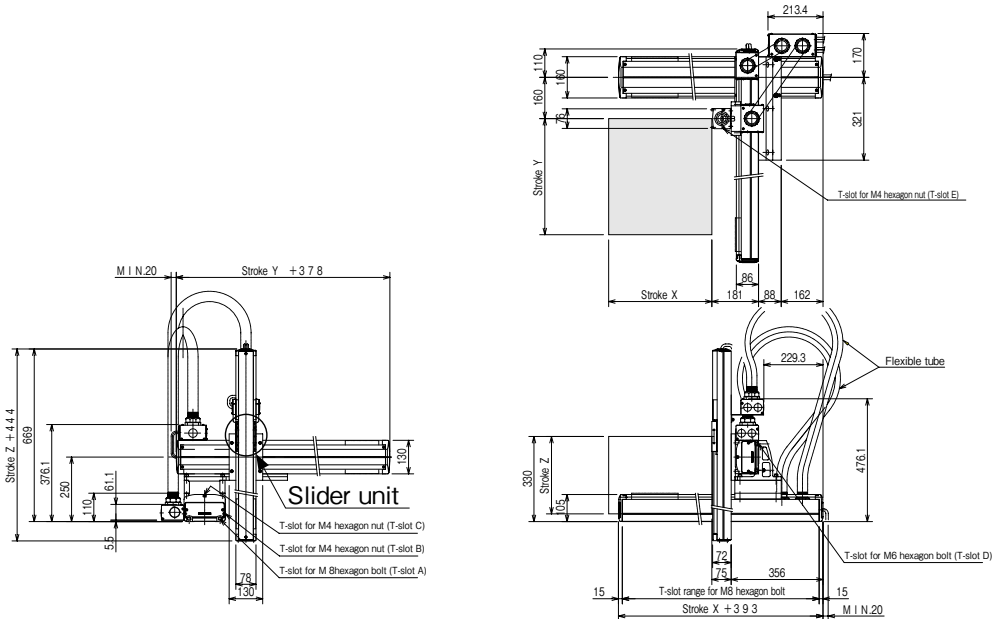
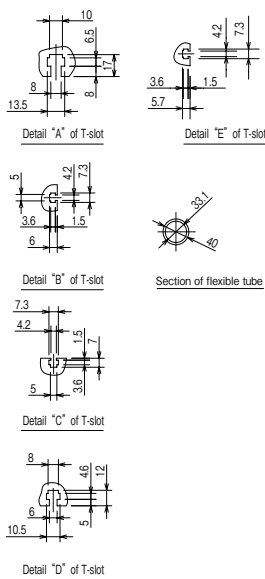

**L: Left-handed**

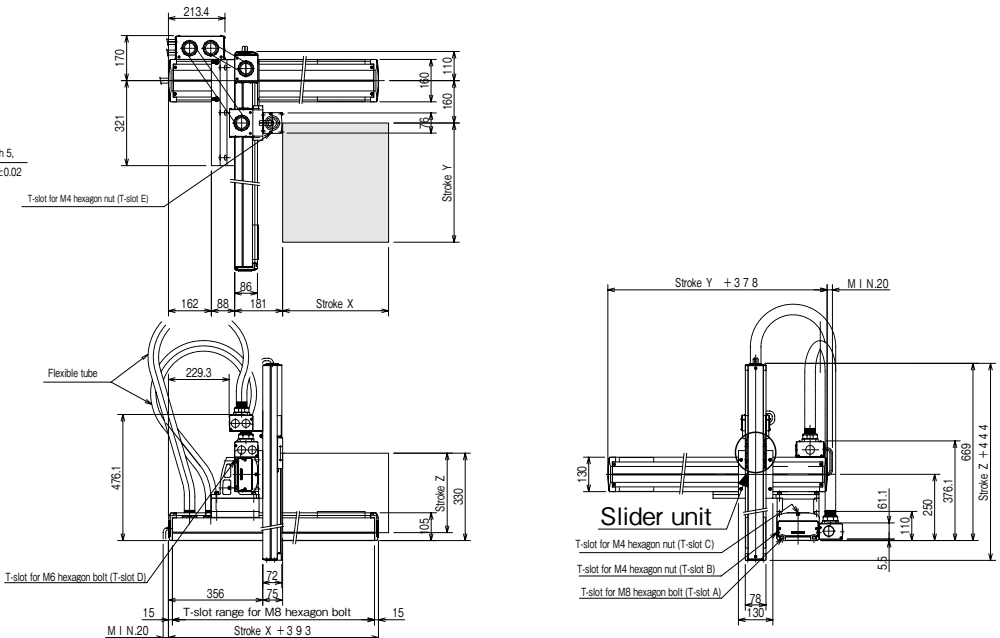
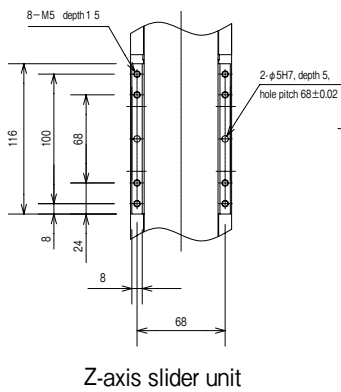

X-Y-Z Flexible-tube Spec.

[Set designation]

**BA2 - A5 - A3A R G - 40 45 30 - OF 2 3**

Combined operation R: Right-handed L: Left-handed	Axis 1 stroke 20 : 200mm 90 : 900mm A0 : 1000mm A5 : 1050mm F0 : 1500mm	Axis 2 stroke 15 : 150mm 65 : 650mm A5 : 1050mm	Axis 3 stroke 10 : 100mm 30 : 300mm	Controller 0: None 1: CA20-M10 2: CA10-M00B 3: CA10-M01B	Cable length 3 : 3m 9 : 9m 5 : 5m B : 11m 7 : 7m D : 13m
---	--	--	---	--	---

**Ball screw type**

- X-axis: Ball screw driven  
Side mounted motor
- Y-axis: Ball screw driven  
Motor straight
- Z-axis: Ball screw driven  
Motor straight

Note 1: When the stroke is as given below, the maximum speed differs.

	Stroke (mm)	Maximum speed (mm/s)
X-axis	700 ~ 800	1100
	900 ~ 1000	1000
	1100 ~ 1200	700
	1300	500
	1400	400
Y-axis	1500	300
	750	1000
	850	800
	950 ~ 1050	600

[Specifications]

	X-axis	Y-axis	Z-axis
Type of axis	BB50F-U □ -M20N- □ 0	BB30E-ST-M20N- □ 5	BB10E-ST-M05B- □ 0
Stroke (in increments of 100 mm)	200 ~ 1500mm	150 ~ 1050mm	100 ~ 300mm
Maximum speed	1200 mm/s (Note 1)	1200 mm/s (Note 1)	300mm/s
Positioning repeatability	±0.01mm		
Ball screw lead	20mm	20mm	5mm
Motor output	200W	100W	100 W, with brake
Resolution	0.01mm		

Acceleration/deceleration time when the maximum speed is set: 0.36 sec. or over

Maximum Payload (kg)	Z-axis stroke	Y-axis stroke									
		150mm	250mm	350mm	450mm	550mm	650mm	750mm	850mm	950mm	1050mm
100mm	100mm	11.0	11.0	11.0	11.0	11.0	11.0	11.0	10.0	8.0	5.0
	200mm	10.0	10.0	10.0	10.0	10.0	10.0	10.0	10.0	7.0	4.0
	300mm	9.0	9.0	9.0	9.0	9.0	9.0	9.0	9.0	6.0	4.0

**R: Right-handed**

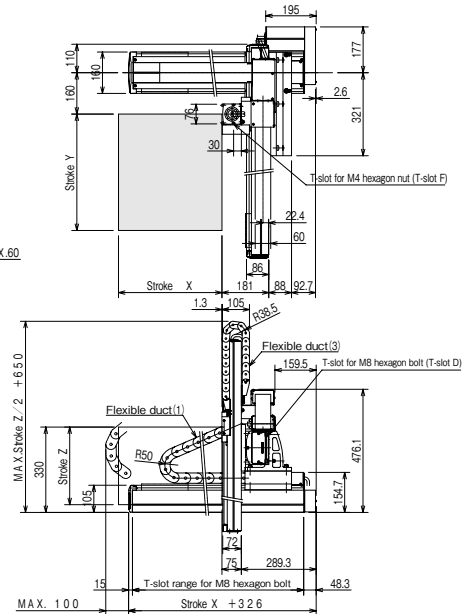
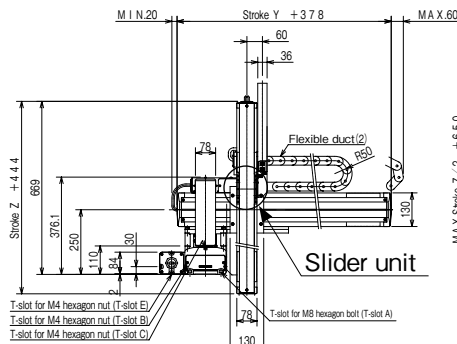
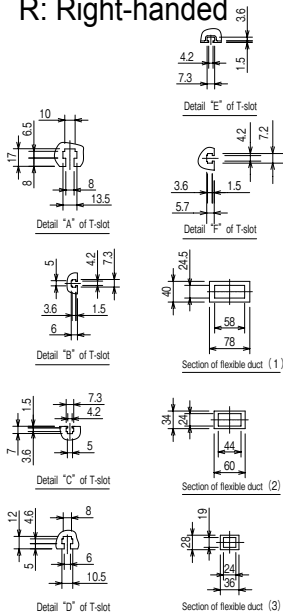

**L: Left-handed**

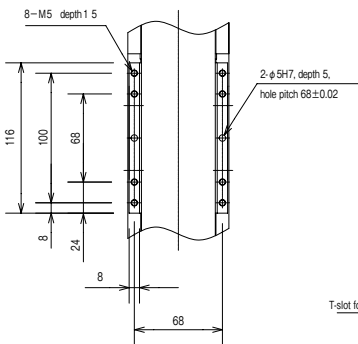

Z-axis slider unit

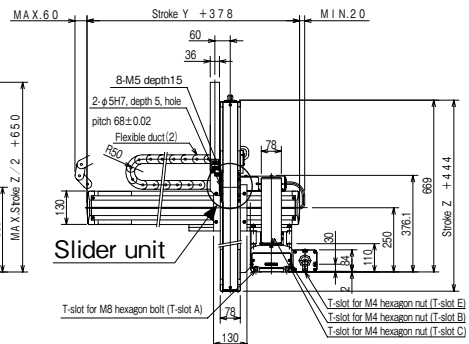
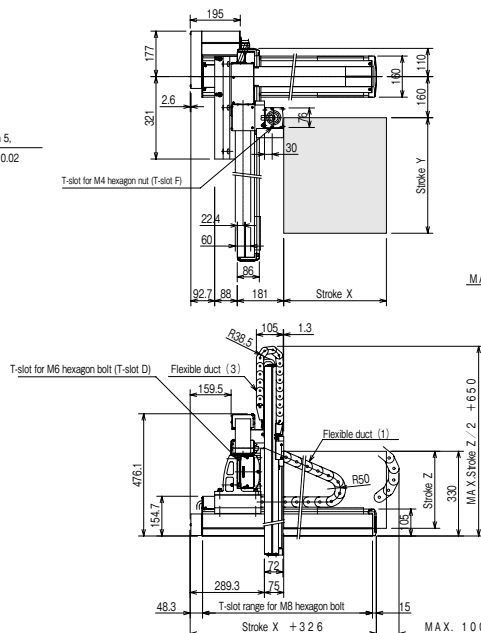

X-Y-Z Flexible-duct Spec., Space-saving type

[Set designation]

**BA2 – A5 – A3A R G – 40 45 30 – OT 2 3**

Combined operation	Axis 1 stroke	Axis 2 stroke	Axis 3 stroke	Controller	Cable length
R: Right-handed L: Left-handed	20 : 200mm 90 : 900mm A0 : 1000mm F0 : 1500mm	15 : 150mm 65 : 650mm A5 : 1050mm	10 : 100mm 30 : 300mm	0: None 1: CA20-M10 2: CA10-M00B 3: CA10-M01B	3 : 3m 9 : 9m 5 : 5m B : 11m 7 : 7m D : 13m

**Ball screw type**

- X-axis: Ball screw driven  
Side mounted motor
- Y-axis: Ball screw driven  
Motor straight
- Z-axis: Ball screw driven  
Motor straight

Note 1: When the stroke is as given below, the maximum speed differs.

	Stroke (mm)	Maximum speed (mm/s)
X-axis	700 ~ 800	1100
	900 ~ 1000	1000
	1100 ~ 1200	700
	1300	500
	1400	400
Y-axis	1500	300
	750	1000
	850	800
	950 ~ 1050	600

[Specifications]

	X-axis	Y-axis	Z-axis
Type of axis	BB50F-U □ -M20N- □ 0	BB30E-ST-M20N- □ 5	BB10E-ST-M05B- □ 0
Stroke (in increments of 100 mm)	200 ~ 1500mm	150 ~ 1050mm	100 ~ 300mm
Maximum speed	1200 mm/s (Note 1)	1200 mm/s (Note 1)	300mm/s
Positioning repeatability	±0.01mm		
Ball screw lead	20mm	20mm	5mm
Motor output	200W	100W	100 W, with brake
Resolution	0.01mm		

Acceleration/deceleration time when the maximum speed is set: 0.36 sec. or over

Maximum Payload (kg)	Y-axis stroke										
	150mm	250mm	350mm	450mm	550mm	650mm	750mm	850mm	950mm	1050mm	
Z-axis stroke	100mm	11.0	11.0	11.0	11.0	11.0	11.0	11.0	10.0	8.0	5.0
	200mm	10.0	10.0	10.0	10.0	10.0	10.0	10.0	10.0	7.0	4.0
	300mm	9.0	9.0	9.0	9.0	9.0	9.0	9.0	9.0	6.0	4.0

**R: Right-handed**

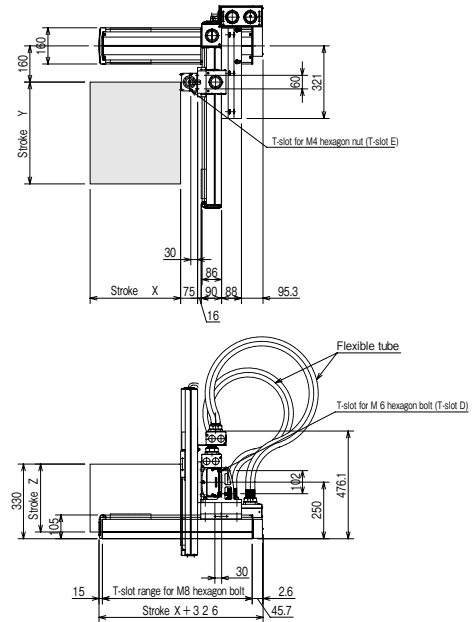
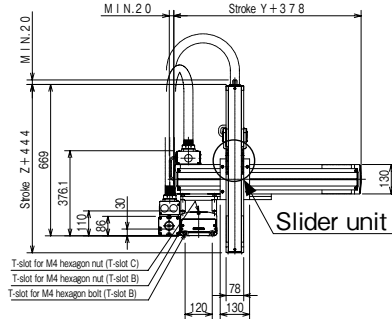
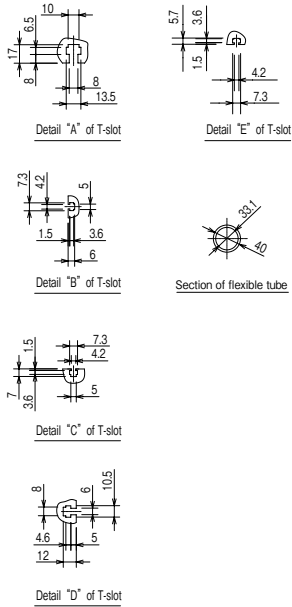

**L: Left-handed**

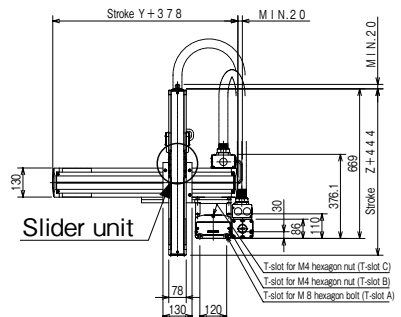
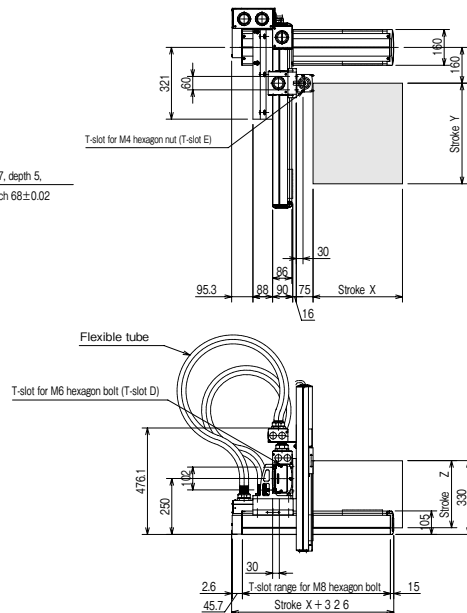
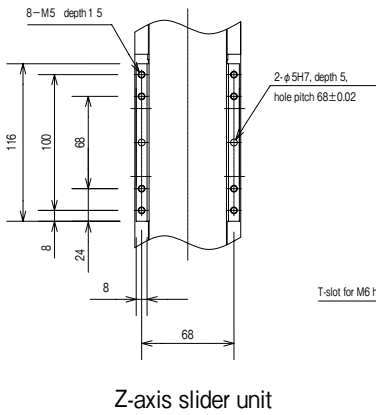



[Set designation]

**BA2 – A5 – A3BR A – 40 40 30 – OF 2 3**

**Ball screw type**

- X-axis: Ball screw driven  
Motor straight
- Y-axis: Ball screw driven  
Motor straight
- Z-axis: Ball screw driven  
Motor straight

Combined operation	Axis 1 stroke	Axis 2 stroke	Axis 3 stroke	Controller	Cable length
R: Right-handed	20 : 200mm	10 : 100mm	10 : 100mm	0: None	3 : 3m 9 : 9m
L: Left-handed	90 : 900mm A0 : 1000mm	90 : 900mm A0 : 1000mm	30 : 300mm	1: CA20-M10 2: CA10-M00B 3: CA10-M01B	5 : 5m B : 11m 7 : 7m D : 13m
	F0 : 1500mm				

Note 1: When the stroke is as given below, the maximum speed differs.

	Stroke (mm)	Maximum speed (mm/s)
X-axis	700 ~ 800	1100
	900 ~ 1000	1000
	1100 ~ 1200	700
	1300	500
	1400	400
Y-axis	1500	300
	700	1000
	800	800
	900 ~ 1000	600

[Specifications]

	X-axis	Y-axis	Z-axis
Type of axis	BB50F-ST-M20N-□ 0	BB30F-ST-M20N-□ 0	BB10E-ST-M05B-□ 0
Stroke (in increments of 100 mm)	200 ~ 1500mm	100 ~ 1000mm	100 ~ 300mm
Maximum speed	1200 mm/s (Note 1)	1200 mm/s (Note 1)	300mm/s
Positioning repeatability	±0.01mm		
Ball screw lead	20mm	20mm	5mm
Motor output	200W	200W	100 W, with brake
Resolution	0.01mm		

Acceleration/deceleration time when the maximum speed is set: 0.36 sec. or over

Maximum Payload (kg)	Y-axis stroke										
	100mm	200mm	300mm	400mm	500mm	600mm	700mm	800mm	900mm	1000mm	
Z-axis stroke	100mm	15.0	15.0	15.0	15.0	15.0	15.0	14.0	11.0	8.0	5.0
	200mm	15.0	15.0	15.0	15.0	15.0	15.0	13.0	10.0	7.0	5.0
	300mm	15.0	15.0	15.0	15.0	15.0	15.0	12.0	10.0	7.0	4.0

R: Right-handed

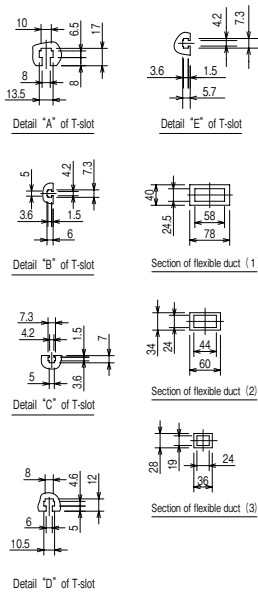

Note 1: When X-axis stroke is 1,100 mm or over, a flexible tray is mounted on the X-axis frame cover.

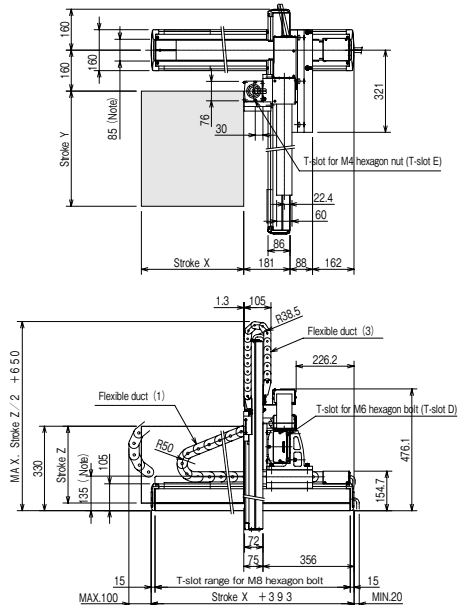
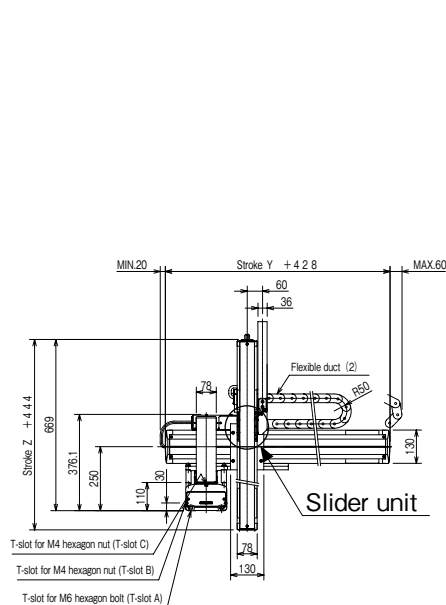

L: Left-handed

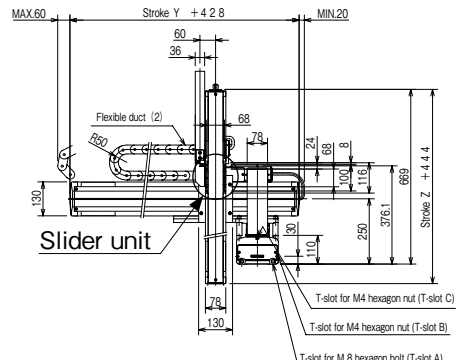
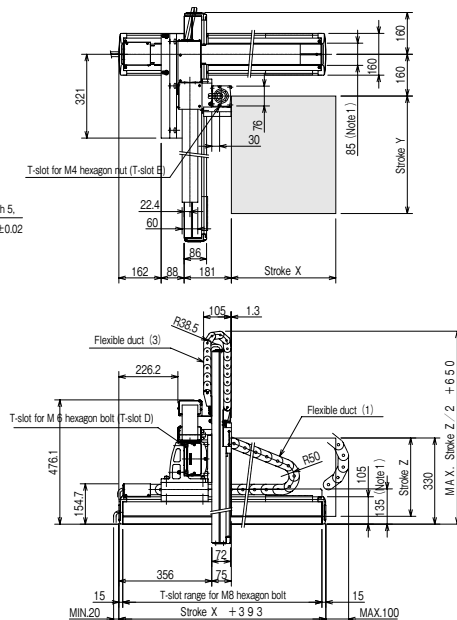
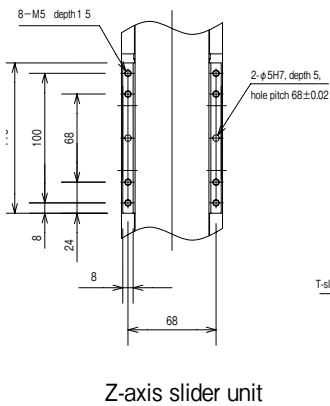

X-Y-Z Flexible-duct Spec.

[Set designation]

**BA2 – A5 – A3BR A – 40 40 30 – OT 2 3**

Combined operation	Axis 1 stroke	Axis 2 stroke	Axis 3 stroke	Controller	Cable length
R: Right-handed	20 : 200mm	10 : 100mm	10 : 100mm	0: None	3 : 3m 9 : 9m
L: Left-handed	90 : 900mm A0 : 1000mm F0 : 1500mm	90 : 900mm A0 : 1000mm	30 : 300mm	1: CA20-M10 2: CA10-M00B 3: CA10-M01B	5 : 5m B : 11m 7 : 7m D : 13m

**Ball screw type**

- X-axis: Ball screw driven  
Motor straight
- Y-axis: Ball screw driven  
Motor straight
- Z-axis: Ball screw driven  
Motor straight

Note 1: When the stroke is as given below, the maximum speed differs.

	Stroke (mm)	Maximum speed (mm/s)
X-axis	700 ~ 800	1100
	900 ~ 1000	1000
	1100 ~ 1200	700
	1300	500
	1400	400
Y-axis	1500	300
	700	1000
	800	800
	900 ~ 1000	600

[Specifications]

	X-axis	Y-axis	Z-axis
Type of axis	BB50F-ST-M20N-□ 0	BB30F-ST-M20N-□ 0	BB10E-ST-M05B-□ 0
Stroke (in increments of 100 mm)	200 ~ 1500mm	100 ~ 1000mm	100 ~ 300mm
Maximum speed	1200 mm/s (Note 1)	1200 mm/s (Note 1)	300mm/s
Positioning repeatability	±0.01mm		
Ball screw lead	20mm	20mm	5mm
Motor output	200W	200W	100 W, with brake
Resolution	0.01mm		

Acceleration/deceleration time when the maximum speed is set: 0.36 sec. or over

Maximum Payload (kg)	Z-axis stroke	Y-axis stroke									
		100mm	200mm	300mm	400mm	500mm	600mm	700mm	800mm	900mm	1000mm
100mm	100mm	15.0	15.0	15.0	15.0	15.0	15.0	14.0	11.0	8.0	5.0
	200mm	15.0	15.0	15.0	15.0	15.0	15.0	13.0	10.0	7.0	5.0
	300mm	15.0	15.0	15.0	15.0	15.0	15.0	12.0	10.0	7.0	4.0

R: Right-handed

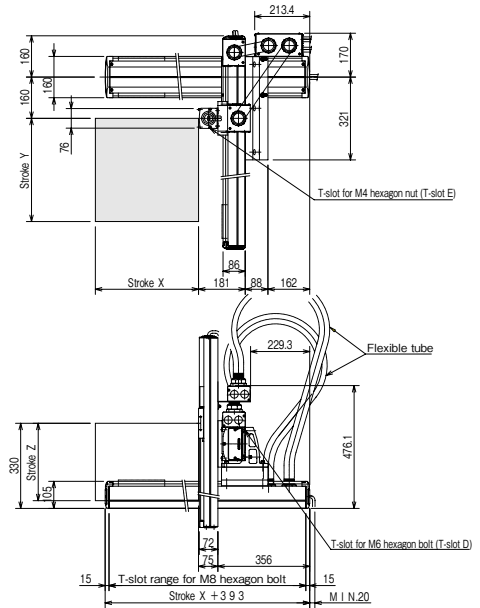
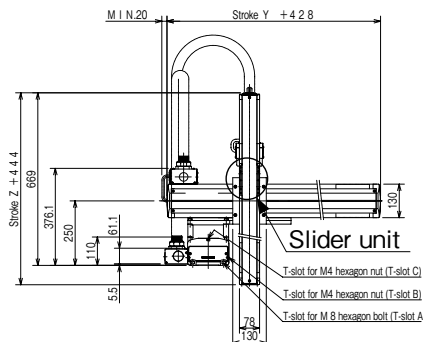
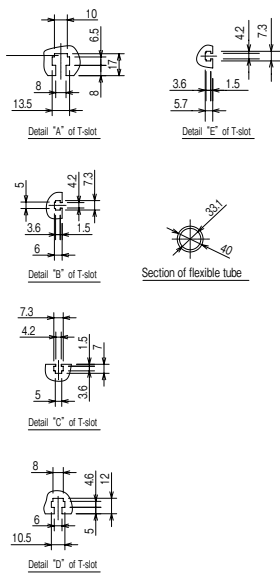

L: Left-handed

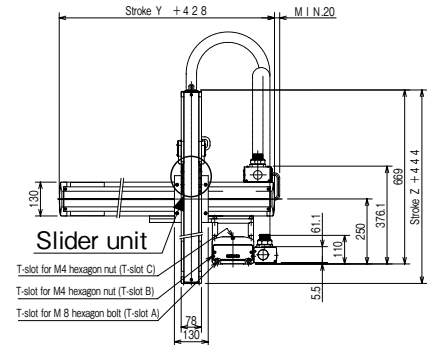
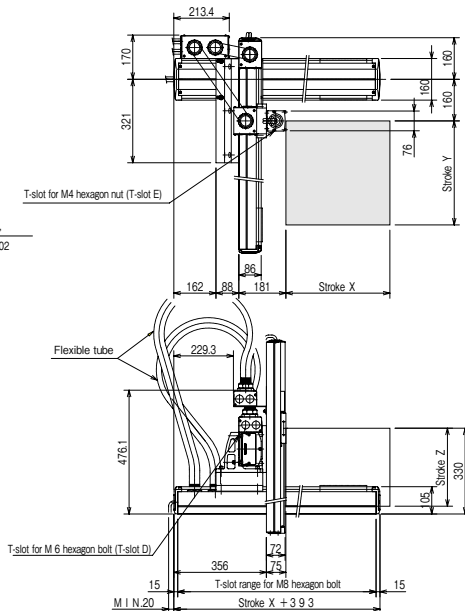
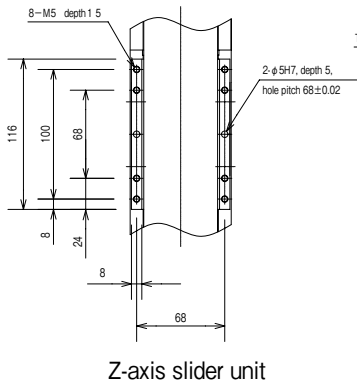

X-Y-Z Flexible-tube Spec.

[Set designation]

**BA2 – A5 – A3B R G – 40 40 30 – OF 2 3**

Combined operation	Axis 1 stroke	Axis 2 stroke	Axis 3 stroke	Controller	Cable length
R: Right-handed L: Left-handed	20 : 200mm 90 : 900mm A0 : 1000mm F0 : 1500mm	10 : 100mm 90 : 900mm A0 : 1000mm	10 : 100mm 30 : 300mm	0: None 1: CA20-M10 2: CA10-M00B 3: CA10-M01B	3 : 3m 9 : 9m 5 : 5m B : 11m 7 : 7m D : 13m

**Ball screw type**

- X-axis: Ball screw driven  
Side mounted motor
- Y-axis: Ball screw driven  
Motor straight
- Z-axis: Ball screw driven  
Motor straight

Note 1: When the stroke is as given below, the maximum speed differs.

	Stroke (mm)	Maximum speed (mm/s)
X-axis	700 ~ 800	1100
	900 ~ 1000	1000
	1100 ~ 1200	700
	1300	500
	1400	400
Z-axis	1500	300
	700	1000
	800	800
	900 ~ 1000	600

[Specifications]

	X-axis	Y-axis	Z-axis
Type of axis	BB50F-U □ -M20N- □ 0	BB30F-ST-M20N- □ 0	BB10E-ST-M05B- □ 0
Stroke (in increments of 100 mm)	200 ~ 1500mm	100 ~ 1000mm	100 ~ 300mm
Maximum speed	1200 mm/s (Note 1)	1200 mm/s (Note 1)	300mm/s
Positioning repeatability	±0.01mm		
Ball screw lead	20mm	20mm	5mm
Motor output	200W	200W	100 W, with brake
Resolution	0.01mm		

Acceleration/deceleration time when the maximum speed is set: 0.36 sec. or over

Maximum Payload (kg)	Y-axis stroke										
	100mm	200mm	300mm	400mm	500mm	600mm	700mm	800mm	900mm	1000mm	
Z-axis stroke	100mm	15.0	15.0	15.0	15.0	15.0	15.0	14.0	11.0	8.0	5.0
	200mm	15.0	15.0	15.0	15.0	15.0	15.0	13.0	10.0	7.0	5.0
	300mm	15.0	15.0	15.0	15.0	15.0	15.0	12.0	10.0	7.0	4.0

R: Right-handed

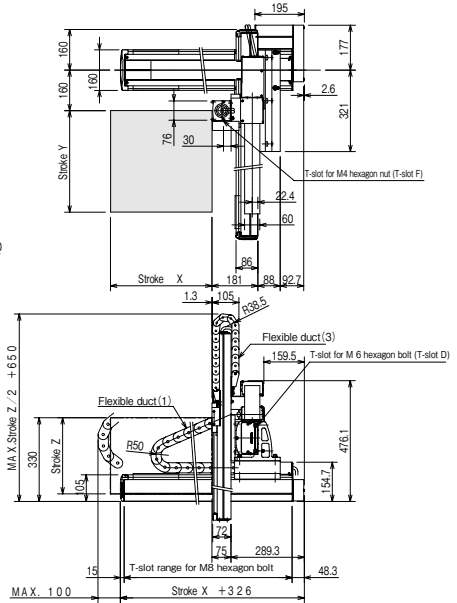
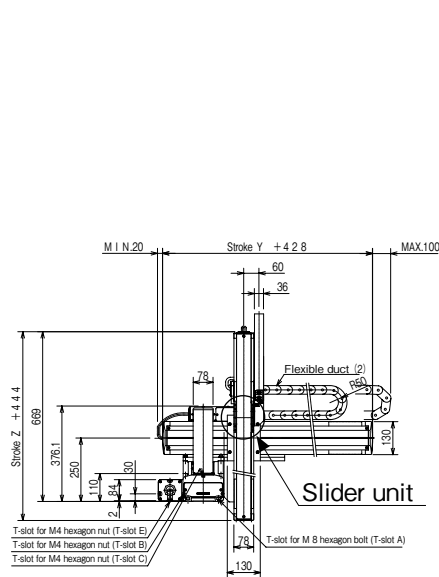
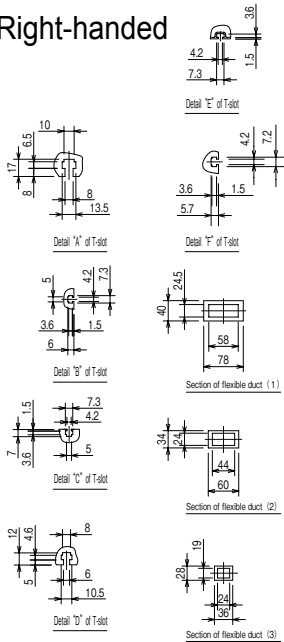

L: Left-handed

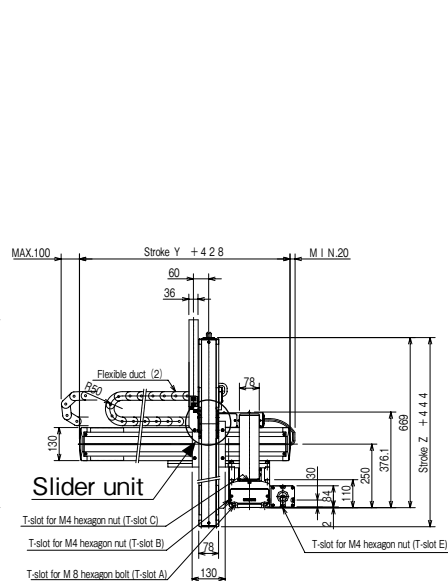
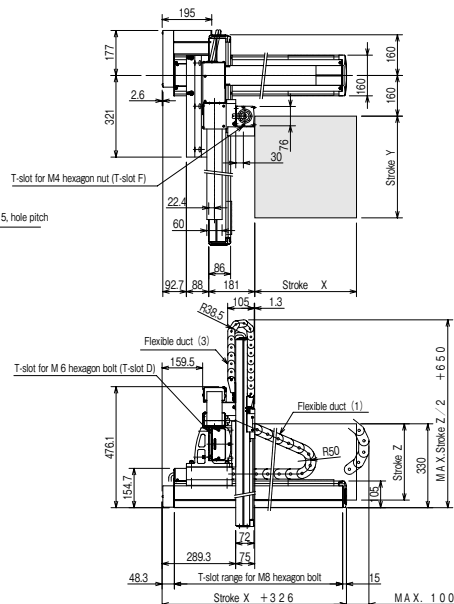
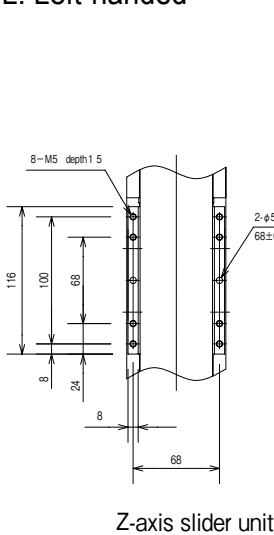

X-Y-Z Flexible-duct Spec., Space-saving type

[Set designation]

**BA2 – A5 – A3B R G – 40 40 30 – OT 2 3**

Combined operation	Axis 1 stroke	Axis 2 stroke	Axis 3 stroke	Controller	Cable length
R: Right-handed L: Left-handed	20 : 200mm 90 : 900mm A0 : 1000mm F0 : 1500mm	10 : 100mm 90 : 900mm A0 : 1000mm	10 : 100mm 30 : 300mm	0: None 1: CA20-M10 2: CA10-M00B 3: CA10-M01B	3 : 3m 9 : 9m 5 : 5m B : 11m 7 : 7m D : 13m

**Ball screw type**

- X-axis: Ball screw driven  
Side mounted motor
- Y-axis: Ball screw driven  
Motor straight
- Z-axis: Ball screw driven  
Motor straight

Note 1: When the stroke is as given below, the maximum speed differs.

	Stroke (mm)	Maximum speed (mm/s)
X-axis	700 ~ 800	1100
	900 ~ 1000	1000
	1100 ~ 1200	700
	1300	500
	1400	400
X-axis	1500	300
	700	1000
	800	800
	900 ~ 1000	600

[Specifications]

	X-axis	Y-axis	Z-axis
Type of axis	BB50F-U □ -M20N- □ 0	BB30F-ST-M20N- □ 0	BB10E-ST-M05B- □ 0
Stroke (in increments of 100 mm)	200 ~ 1500mm	100 ~ 1000mm	100 ~ 300mm
Maximum speed	1200 mm/s (Note 1)	1200 mm/s (Note 1)	300mm/s
Positioning repeatability	±0.01mm		
Ball screw lead	20mm	20mm	5mm
Motor output	200W	200W	100 W, with brake
Resolution	0.01mm		

Acceleration/deceleration time when the maximum speed is set: 0.36 sec. or over

Maximum Payload (kg)	Z-axis stroke	Y-axis stroke										
		100mm	200mm	300mm	400mm	500mm	600mm	700mm	800mm	900mm	1000mm	
100mm	100mm	15.0	15.0	15.0	15.0	15.0	15.0	15.0	14.0	11.0	8.0	5.0
	200mm	15.0	15.0	15.0	15.0	15.0	15.0	15.0	13.0	10.0	7.0	5.0
	300mm	15.0	15.0	15.0	15.0	15.0	15.0	15.0	12.0	10.0	7.0	4.0

**R: Right-handed**

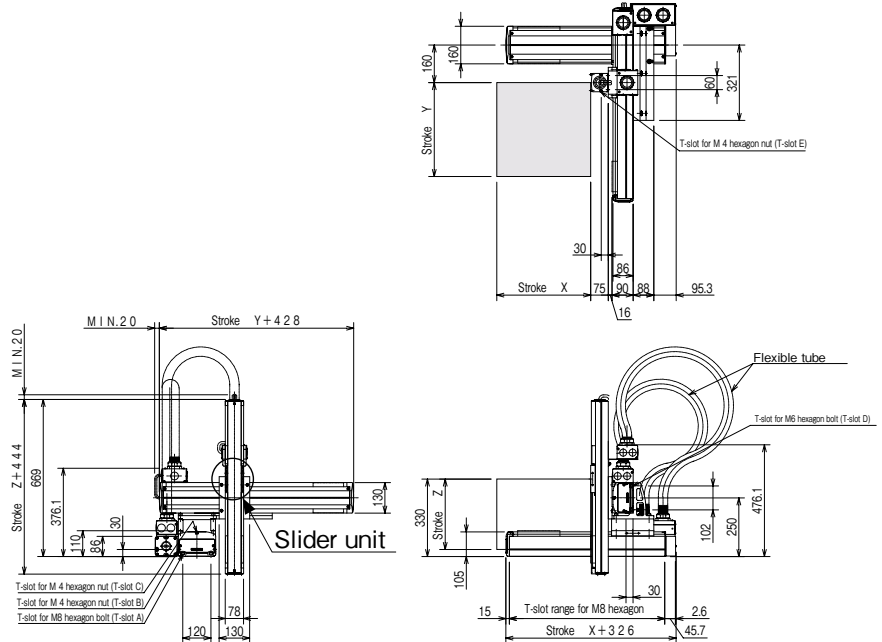
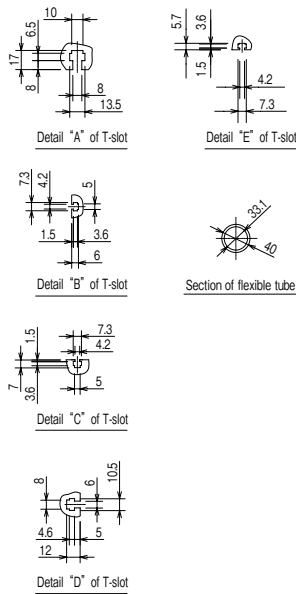

**L: Left-handed**

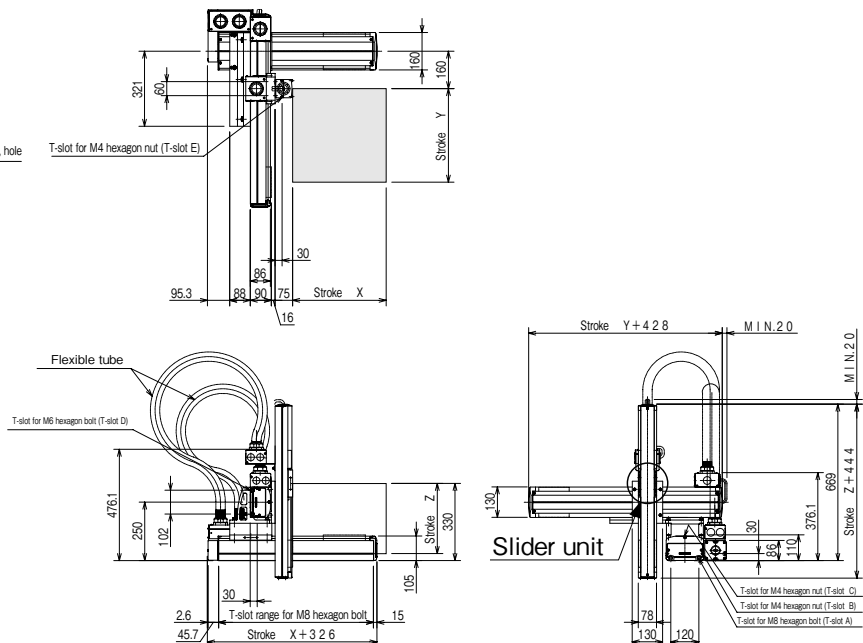
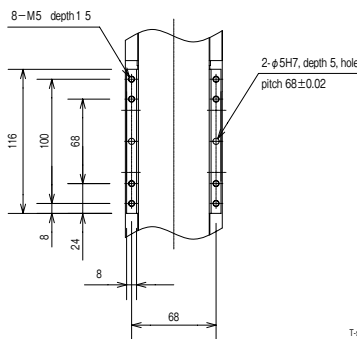

[Set designation]

BA2 - L1 - J3A R G - 45 40 30 - OF 2 3

Timing belt type

- X-axis: Timing belt driven  
Side mounted motor
- Y-axis: Ball screw driven  
Motor straight
- Z-axis: Ball screw driven  
Motor straight

Combined operation R: Right-handed L: Left-handed	Axis 1 stroke	Axis 2 stroke	Axis 3 stroke	Controller	Cable length
	15 : 150mm 95 : 950mm A5 : 1050mm H5 : 1750mm J5 : 1850mm	05 : 50mm 30 : 300mm	05 : 50mm 30 : 300mm	0: None 1: CA20-M10 2: CA10-M00B 3: CA10-M01B	3 : 3m 9 : 9m 5 : 5m B : 11m 7 : 7m D : 13m

[Specifications]

	X-axis	Y-axis	Z-axis
Type of axis	BB10E-BT-M21N-□ 5	BB07D-ST-M21N-□□	BB05D-ST-M12B-□□
Stroke (X- and Y-axes in increments of 100 mm, Z-axis in increments of 50 mm)	150 ~ 1850mm	150 ~ 300mm	50 ~ 300mm
Maximum speed	1000mm/s	800mm/s	800mm/s
Positioning repeatability	±0.05mm	±0.02mm	±0.02mm
Ball screw lead	21 mm (lead converted into ball screw)	12mm	12mm
Motor output	100W	50W	50 W, with brake
Resolution	0.01mm		

Acceleration/deceleration time when the maximum speed is set: 0.3 sec. or over

Maximum Payload (kg)		Y-axis stroke					
		50mm	100mm	150mm	200mm	250mm	300mm
Z-axis stroke	50,100mm	3.0	3.0	3.0	3.0	1.2	1.2
	150,200mm	3.0	3.0	3.0	3.0	1.0	1.0
	250,300mm	3.0	3.0	3.0	3.0	0.8	0.8

R: Right-handed

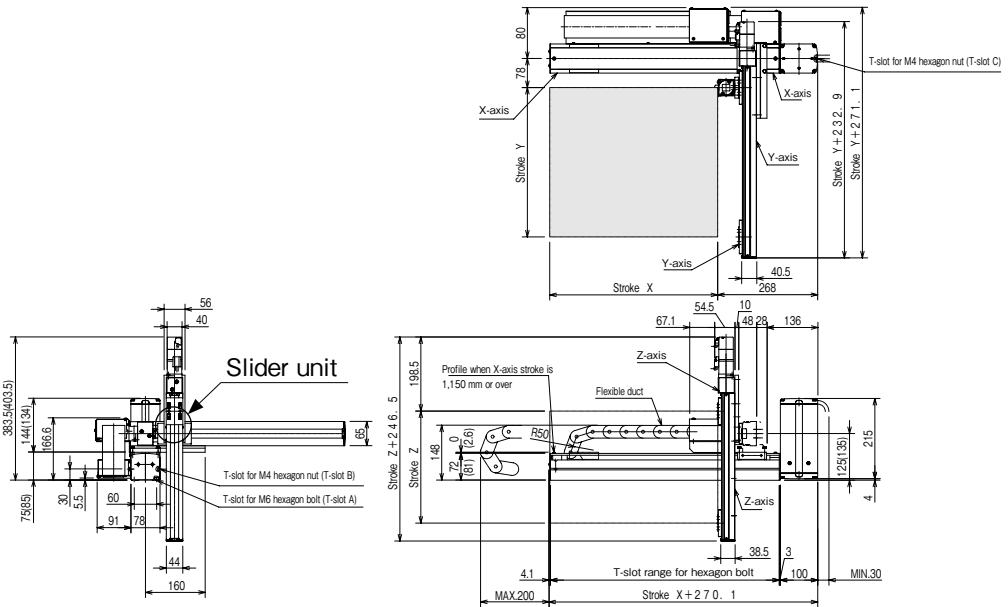
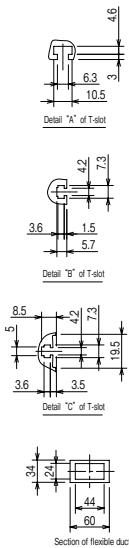

Values in parentheses are applicable to X-axis stroke 1,150 mm or over.

L: Left-handed

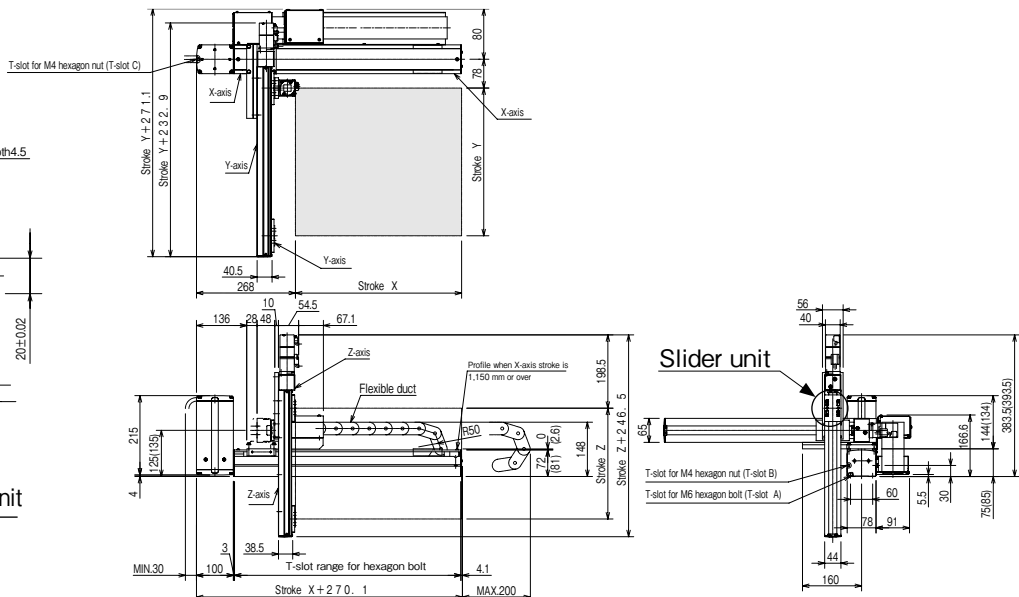
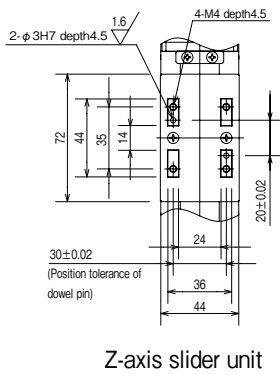

X-Y-Z Flexible-duct Spec.

[Set designation]

**BA2 - L1 - A3C R C - 40 45 30 - OF 2 3**

**Timing belt type**

Combined operation	Axis 1 stroke	Axis 2 stroke	Axis 3 stroke	Controller	Cable length
R: Right-handed	10 : 100mm	15 : 150mm	05 : 50mm	0: None	3 : 3m 9 : 9m
L: Left-handed	90 : 900mm A0 : 1000mm HO : 1700mm JO : 1800mm	45 : 450mm	30 : 300mm	1: CA20-M10 2: CA10-M00B 3: CA10-M01B	5 : 5m B : 11m 7 : 7m D : 13m

- X-axis: Timing belt driven  
Side mounted motor
- Y-axis: Timing belt driven  
Side mounted motor
- Z-axis: Ball screw driven  
Motor straight

[Specifications]

	X-axis	Y-axis	Z-axis
Type of axis	BB10E-BT-M21N-□ 0	BB10E-B□ -S21N-□ 5	BB07D-ST-M12B-□ □
Stroke (X- and Y-axes in increments of 100 mm, Z-axis in increments of 50 mm)	100 ~ 1800mm	150 ~ 450mm	50 ~ 300mm
Maximum speed	1000mm/s	1000mm/s	800mm/s
Positioning repeatability	±0.05mm	±0.05mm	±0.02mm
Ball screw lead	21 mm (lead converted into ball screw)	21 mm (lead converted into ball screw)	12mm
Motor output	100W	100W	50 W, with brake
Resolution	0.01mm		

Acceleration/deceleration time when the maximum speed is set: 0.4 sec. or over

Maximum Payload (kg)		Y-axis stroke			
		150mm	250mm	350mm	450mm
Z-axis stroke	50,100mm	4.0	4.0	2.5	1.5
	150,200mm	4.0	3.0	2.1	1.1
	250,300mm	4.0	3.0	1.7	0.7

R: Right-handed

The values in parentheses are applicable when the X-axis stroke is 1,100 mm or over.

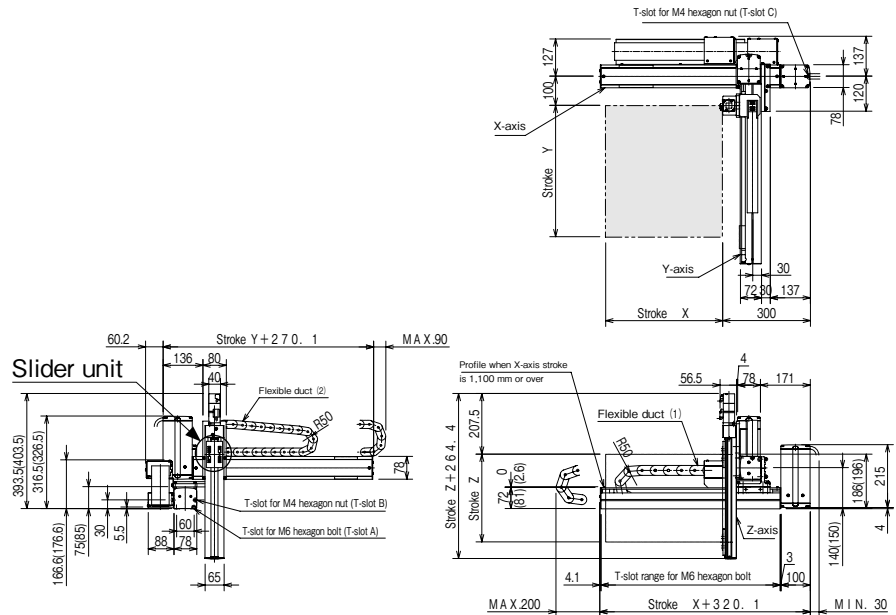
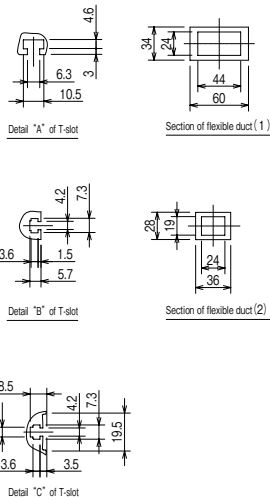

L: Left-handed

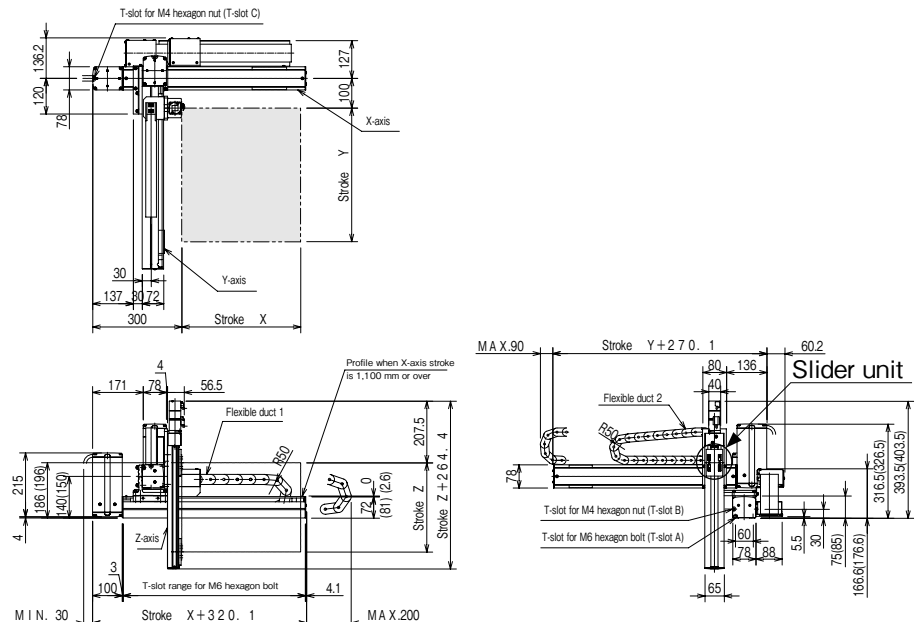
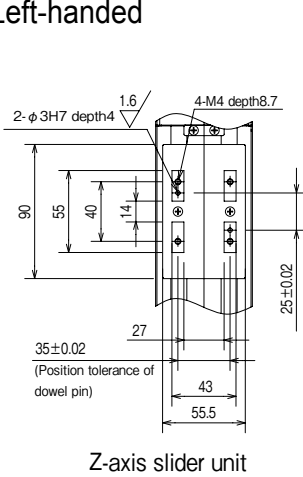

X-Y-Z Flexible-duct Spec.

[Set designation]

BA2 – L1 – A3F R C – 40 45 30 – OF 2 3

Timing belt type

- X-axis: Timing belt driven  
Side mounted motor
- Y-axis: Timing belt driven  
Side mounted motor
- Z-axis: Ball screw driven  
Motor straight

Combined operation	Axis 1 stroke	Axis 2 stroke	Axis 3 stroke	Controller	Cable length
R: Right-handed	10 : 100mm	15 : 150mm	05 : 50mm	0: None	3 : 3m 9 : 9m
L: Left-handed	90 : 900mm	45 : 450mm	30 : 300mm	1: CA20-M10	5 : 5m B : 11m
	A0 : 1000mm			2: CA10-M00B	7 : 7m D : 13m
	H0 : 1700mm			3: CA10-M01B	
	J0 : 1800mm				

[Specifications]

	X-axis	Y-axis	Z-axis
Type of axis	BB10F-BT-M21N-□ 0	BB10E-B□ -S21N-□ 5	BB07D-ST-M12B-□ □
Stroke (X- and Y-axes in increments of 100 mm, Z-axis in increments of 50 mm)	100 ~ 1800mm	150 ~ 450mm	50 ~ 300mm
Maximum speed	1000mm/s	1000mm/s	800mm/s
Positioning repeatability	±0.05mm	±0.05mm	±0.02mm
Ball screw lead	21 mm (lead converted into ball screw)	21 mm (lead converted into ball screw)	12mm
Motor output	200W	100W	50 W, with brake
Resolution	0.01mm		

Acceleration/deceleration time when the maximum speed is set: 0.3 sec. or over

Maximum Payload (kg)	Y-axis stroke			
	150mm	250mm	350mm	450mm
Z-axis stroke				
50,100mm	4.0	4.0	2.5	1.5
150,200mm	4.0	3.0	2.1	1.1
250,300mm	4.0	3.7	1.7	0.7

R: Right-handed

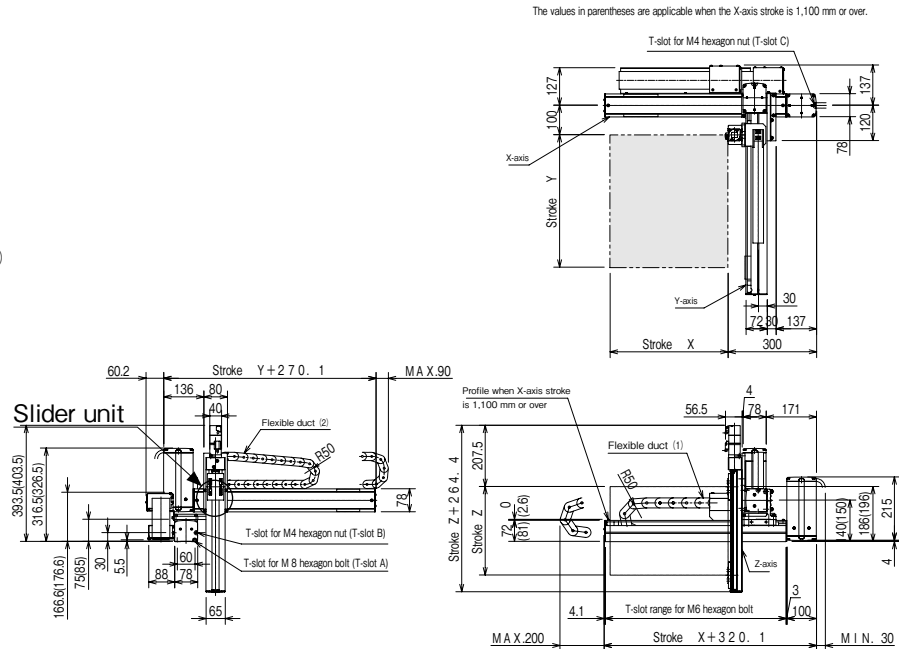
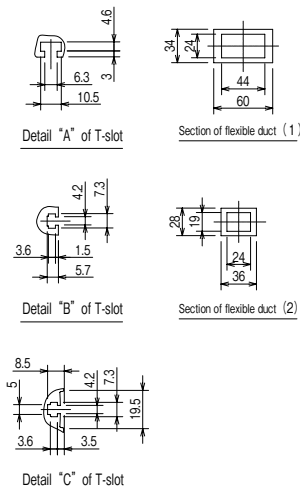

L: Left-handed

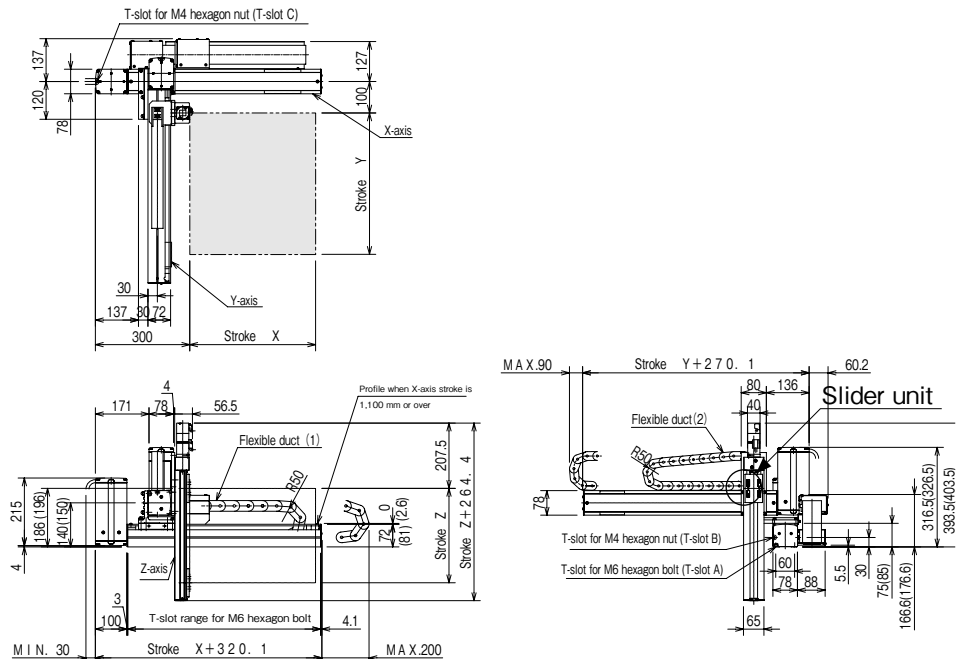
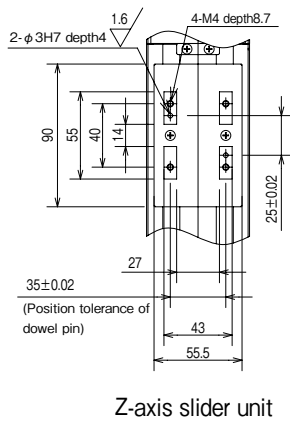

X-Y-Z Flexible-duct Spec.

[Set designation]

**BA2 – L3 – A3E R C – 40 45 30 – OF 2 3**

**Timing belt type**

- X-axis: Timing belt driven  
Side mounted motor
- Y-axis: Timing belt driven  
Side mounted motor
- Z-axis: Ball screw driven  
Motor straight

Combined operation	Axis 1 stroke	Axis 2 stroke	Axis 3 stroke	Controller	Cable length
R: Right-handed	10 : 100mm JO : 1800mm	15 : 150mm	05 : 50mm	0: None	3 : 3m 9 : 9m
L: Left-handed	90 : 900mm NO : 2200mm	55 : 550mm	30 : 300mm	1: CA20-M10	5 : 5m B : 11m
	A0 : 1000mm PO : 2300mm			2: CA10-M00B	7 : 7m D : 13m
	H0 : 1700mm R0 : 2500mm			3: CA10-M01B	

[Specifications]

	X-axis	Y-axis	Z-axis
Type of axis	BB30E-BT-M21N- □ 0	BB10E-B □ -S21N- □ 0	BB07D-ST-M12B- □ □
Stroke (X- and Y-axes in increments of 100 mm, Z-axis in increments of 50 mm)	100 ~ 2500mm	150 ~ 550mm	50 ~ 300mm
Maximum speed	1000mm/s	1000mm/s	800mm/s
Positioning repeatability	±0.05mm	±0.05mm	±0.02mm
Ball screw lead	21 mm (lead converted into ball screw)	21 mm (lead converted into ball screw)	12mm
Motor output	100W	100W	50 W, with brake
Resolution	0.01mm		

Acceleration/deceleration time when the maximum speed is set: 0.3 sec. or over

Maximum Payload (kg)	Y-axis stroke				
	150mm	250mm	350mm	450mm	550mm
Z-axis stroke					
50,100mm	3.0	3.0	2.0	2.0	1.0
150,200mm	3.0	2.0	2.0	1.0	1.0
250,300mm	3.0	2.0	1.0	1.0	—

**R: Right-handed**

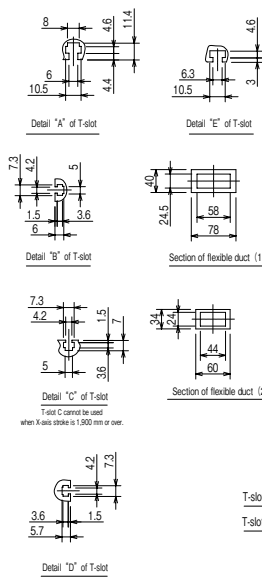

**Slider unit**

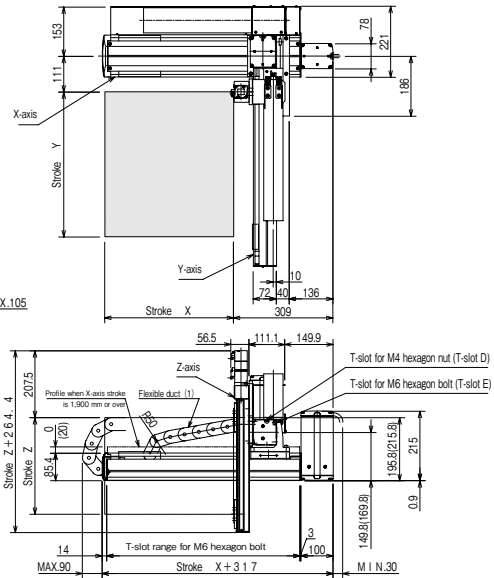
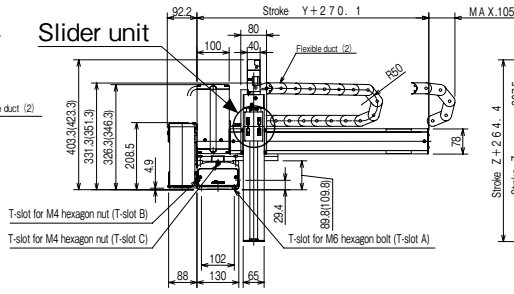

The values in parentheses are applicable when the X-axis stroke is 1,900 mm or over.

**L: Left-handed**

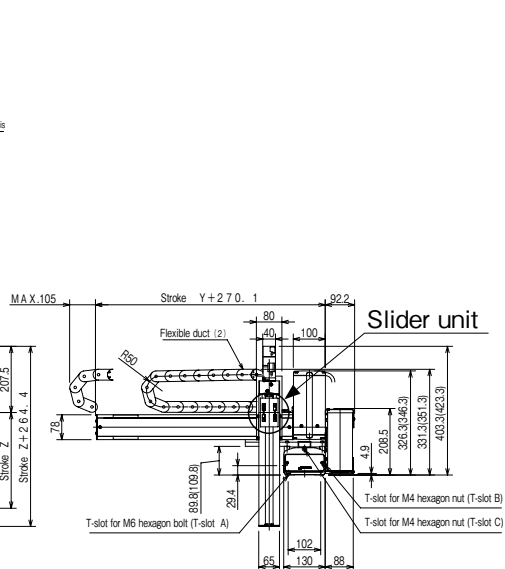
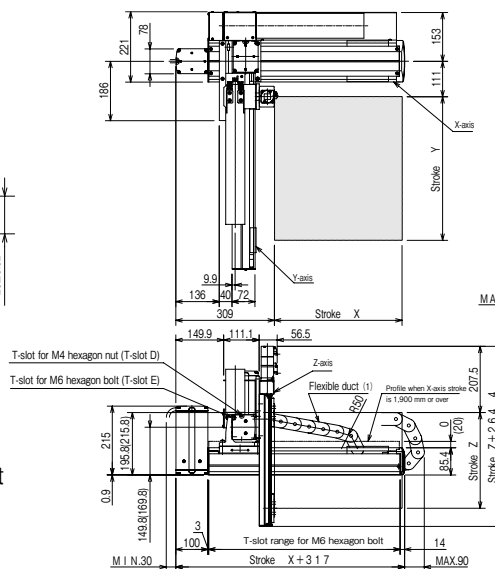
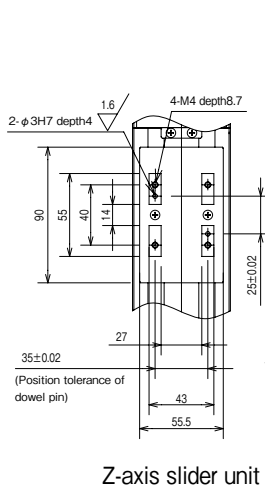

X-Y-Z Flexible-duct Spec.



[Set designation]

BA2 – L3 – A3G R C – 40 45 30 – OF 2 3

Timing belt type

- X-axis: Timing belt driven  
Side mounted motor
- Y-axis: Timing belt driven  
Side mounted motor
- Z-axis: Ball screw driven  
Motor straight

Combined operation	Axis 1 stroke	Axis 2 stroke	Axis 3 stroke	Controller	Cable length
R: Right-handed	10 : 100mm J0 : 1800mm	15 : 150mm	05 : 50mm	0: None	3 : 3m 9 : 9m
L: Left-handed	90 : 900mm N0 : 2200mm A0 : 1000mm P0 : 2300mm	85 : 850mm	30 : 300mm	1: CA20-M10 2: CA10-M00B 3: CA10-M01B	5 : 5m B : 11m 7 : 7m D : 13m
	H0 : 1700mm R0 : 2500mm				

[Specifications]

	X-axis	Y-axis	Z-axis
Type of axis	BB30F-BT-M21N-□0	BB10E-B□-S21N-□5	BB07D-ST-M12B-□□
Stroke (X- and Y-axes in increments of 100 mm, Z-axis in increments of 50 mm)	100 ~ 2500mm	150 ~ 850mm	50 ~ 300mm
Maximum speed	1000mm/s	1000mm/s	800mm/s
Positioning repeatability	±0.05mm	±0.05mm	±0.02mm
Ball screw lead	21 mm (lead converted into ball screw)	21 mm (lead converted into ball screw)	12mm
Motor output	200W	100W	50 W, with brake
Resolution	0.01mm		

Acceleration/deceleration time when the maximum speed is set: 0.3 sec. or over

Maximum Payload (kg)	Z-axis stroke	Y-axis stroke							
		150mm	250mm	350mm	450mm	550mm	650mm	750mm	850mm
50, 100mm	50, 100mm	4.0	4.0	4.0	4.0	4.0	4.0	2.3	0.8
	150, 200mm	4.0	4.0	4.0	4.0	4.0	3.7	2.0	0.4
	250, 300mm	4.0	4.0	4.0	4.0	4.0	3.4	1.6	0.1

R: Right-handed

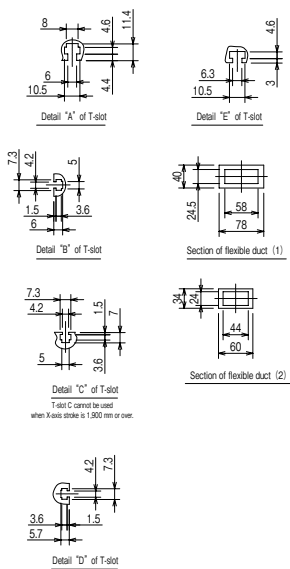

The values in parentheses are applicable when the X-axis stroke is 1,900 mm or over.

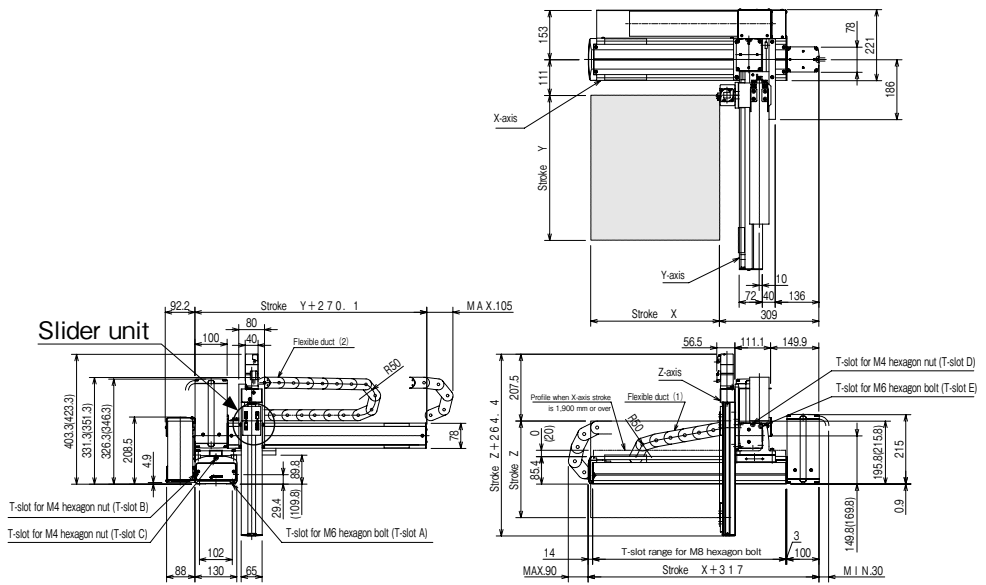

L: Left-handed

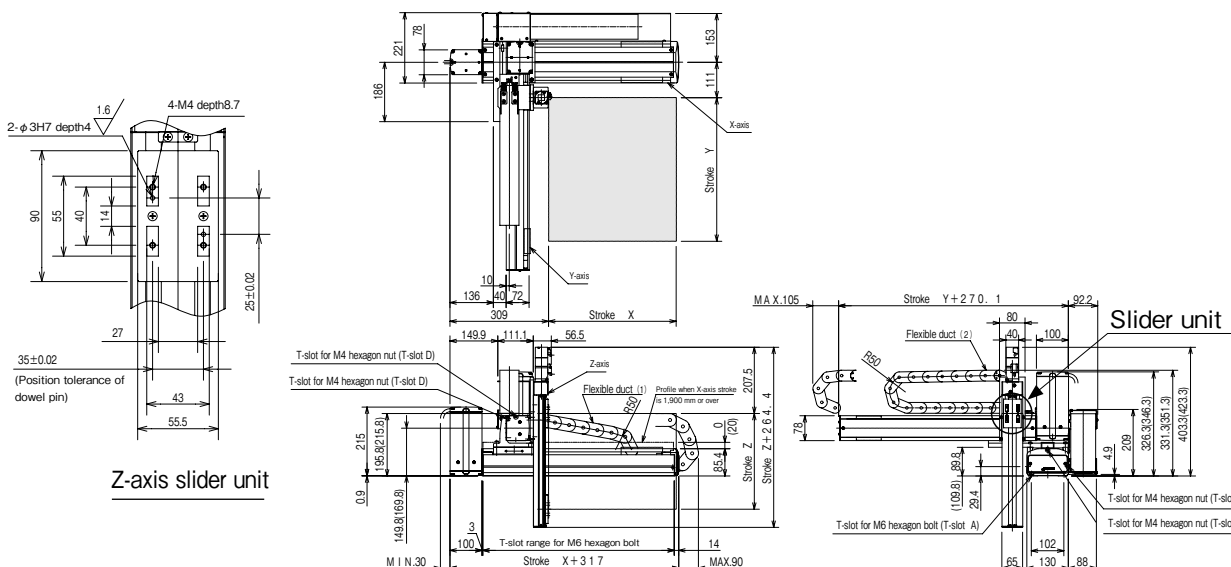

X-Y-Z Flexible-duct Spec.

[Set designation]

**BA2 – L3 – A3B R D – 40 45 30 – OF 2 3**

**Timing belt type**

- X-axis: Timing belt driven  
Side mounted motor
- Y-axis: Timing belt driven  
Side mounted motor
- Z-axis: Ball screw driven  
Side mounted motor

Combined operation	Axis 1 stroke	Axis 2 stroke	Axis 3 stroke	Controller	Cable length
R: Right-handed	10 : 100mm J0 : 1800mm	10 : 100mm	15 : 150mm	0: None	3 : 3m 9 : 9m
L: Left-handed	90 : 900mm N0 : 2200mm A0 : 1000mm P0 : 2300mm	50 : 500mm	35 : 350mm	1: CA20-M10 2: CA10-M00B 3: CA10-M01B	5 : 5m B : 11m 7 : 7m D : 13m
	H0 : 1700mm R0 : 2500mm				

[Specifications]

	X-axis	Y-axis	Z-axis
Type of axis	BB30F-BT-M21N-□ 0	BB10E-B□ -M21N-□ 0	BB10E-U□ -S10B-□ 5
Stroke (in increments of 100 mm)	100 ~ 2500mm	100 ~ 500mm	150 ~ 350mm
Maximum speed	1000mm/s	1000mm/s	600mm/s
Positioning repeatability	±0.05mm	±0.05mm	±0.01mm
Ball screw lead	21 mm (lead converted into ball screw)	21 mm (lead converted into ball screw)	10mm
Motor output	200W	100W	100 W, with brake
Resolution	0.01mm		

Acceleration/deceleration time when the maximum speed is set: 0.3 sec. or over

Maximum Payload (kg)	Y-axis stroke					
	100mm	200mm	300mm	400mm	500mm	
Z-axis stroke	150mm	8.0	8.0	7.0	4.0	2.0
	250mm	7.0	7.0	6.0	4.0	1.0
	350mm	6.0	6.0	6.0	3.0	1.0

R: Right-handed

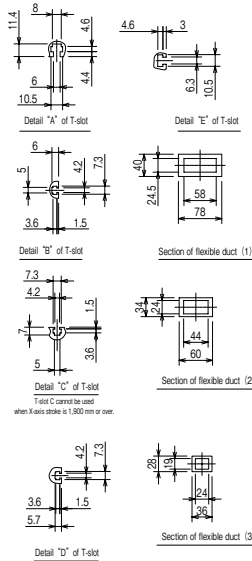

The values in parentheses are applicable when the X-axis stroke is 1,900 mm or over.

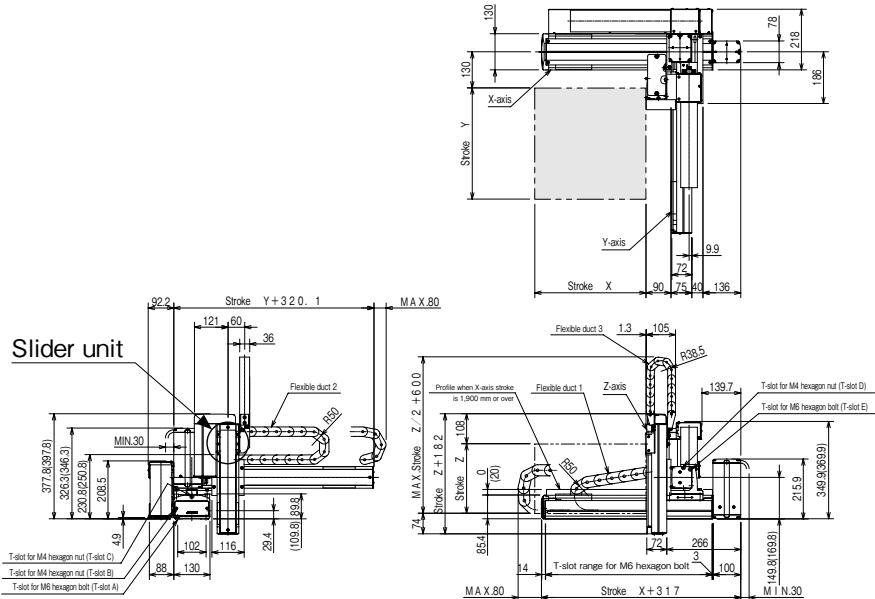

L: Left-handed

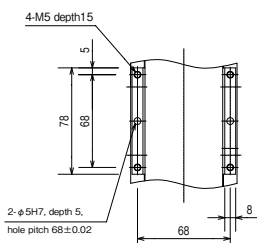

Z-axis slider unit

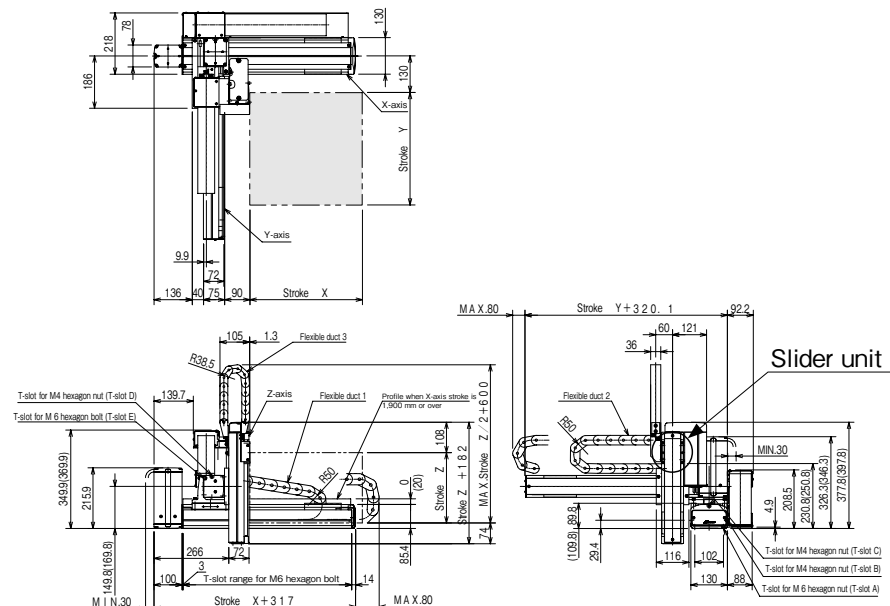

[Set designation]

**BA2 - L5 - A3A R C - 40 40 30 - OF 2 3**

Timing belt type

- X-axis: Timing belt driven  
Side mounted motor
- Y-axis: Timing belt driven  
Side mounted motor
- Z-axis: Ball screw driven  
Side mounted motor

Combined operation	Axis 1 stroke	Axis 2 stroke	Axis 3 stroke	Controller	Cable length
R: Right-handed	20 : 200mm J0 : 1800mm	10 : 100mm	10 : 100mm	0: None	3 : 3m 9 : 9m
L: Left-handed	90 : 900mm N0 : 2200mm	90 : 900mm	30 : 300mm	1: CA20-M10	5 : 5m B : 11m
	A0 : 1000mm P0 : 2300mm	A0 : 1000mm		2: CA10-M00B	7 : 7m D : 13m
	H0 : 1700mm R0 : 2500mm			3: CA10-M01B	

[Specifications]

	X-axis	Y-axis	Z-axis
Type of axis	BB50F-BT-M21N-□ 0	BB30E-B□ -M21N-□ 0	BB10E-U□ -M05B-□ 0
Stroke (in increments of 100 mm)	200 ~ 2500mm	100 ~ 1000mm	100 ~ 300mm
Maximum speed	1000mm/s	1000mm/s	300mm/s
Positioning repeatability	±0.05mm	±0.05mm	±0.01mm
Ball screw lead	21 mm (lead converted into ball screw)	21 mm (lead converted into ball screw)	5mm
Motor output	200W	100W	100 W, with brake
Resolution	0.01mm		

Acceleration/deceleration time when the maximum speed is set: 0.36 sec. or over

Maximum Payload (kg)	Y-axis stroke									
	100mm	200mm	300mm	400mm	500mm	600mm	700mm	800mm	900mm	1000mm
Z-axis stroke	100mm	7.0	7.0	7.0	7.0	7.0	7.0	7.0	6.0	5.0
	200mm	7.0	7.0	7.0	7.0	7.0	7.0	7.0	5.0	4.0
	300mm	6.0	6.0	6.0	6.0	6.0	6.0	6.0	5.0	4.0

R: Right-handed

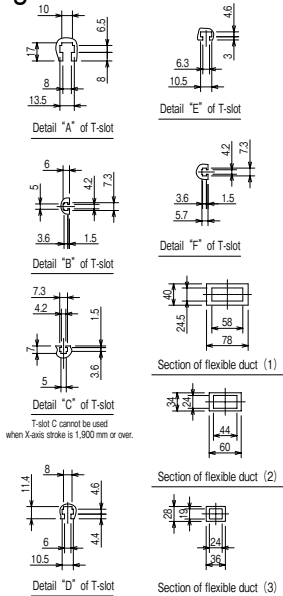

The values in parentheses are applicable when the X-axis stroke is 1,900 mm or over.

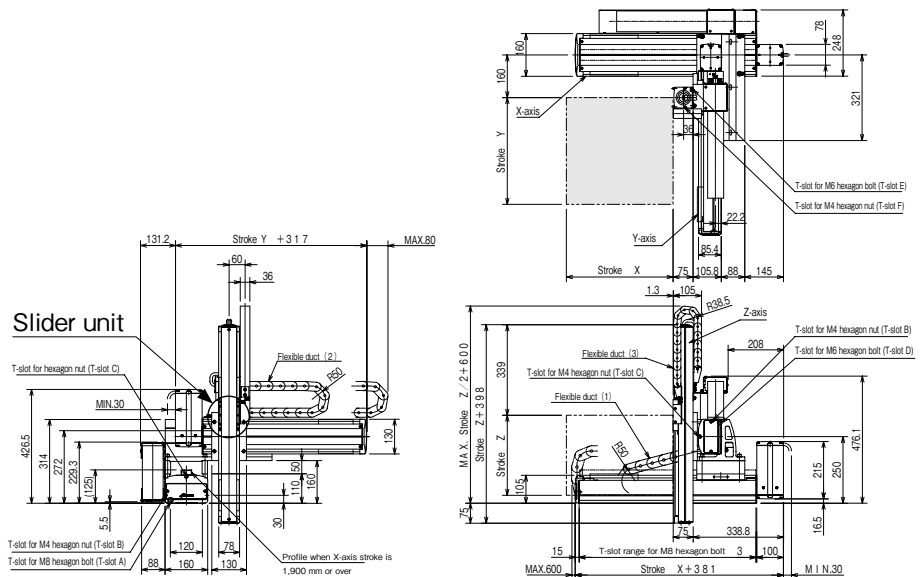

L: Left-handed

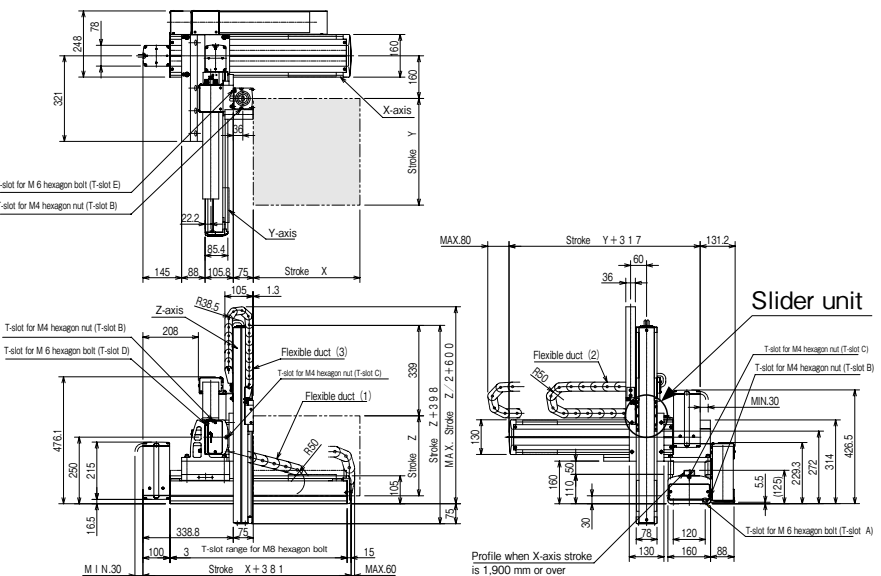
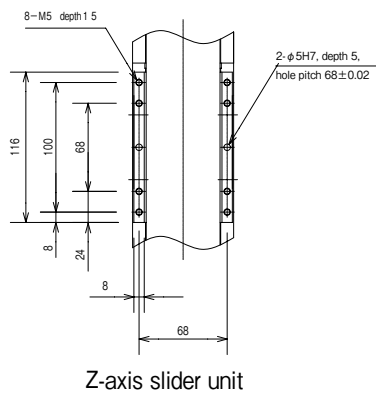

X-Y-Z Flexible-duct Spec.

[Set designation]

**BA2 – L5 – A3B R C – 40 40 30 – OF 2 3**

Combined operation	Axis 1 stroke	Axis 2 stroke	Axis 3 stroke	Controller	Cable length
R: Right-handed	20 : 200mm J0 : 1800mm	10 : 100mm	10 : 100mm	0: None	3 : 3m 9 : 9m
L: Left-handed	90 : 900mm N0 : 2200mm A0 : 1000mm P0 : 2300mm	90 : 900mm A0 : 1000mm	30 : 300mm	1: CA20-M10 2: CA10-M00B 3: CA10-M01B	5 : 5m B : 11m 7 : 7m D : 13m
	H0 : 1700mm R0 : 2500mm				

**Timing belt type**

- X-axis: Timing belt driven  
Side mounted motor
- Y-axis: Timing belt driven  
Side mounted motor
- Z-axis: Ball screw driven  
Side mounted motor

[Specifications]

	X-axis	Y-axis	Z-axis
Type of axis	BB50F-BT-M21N-□ 0	BB30F-B□ -M21N-□ 0	BB10E-U □ -M05B-□ 0
Stroke (in increments of 100 mm)	200 ~ 2500mm	100 ~ 1000mm	100 ~ 300mm
Maximum speed	1000mm/s	1000mm/s	300mm/s
Positioning repeatability	±0.05mm	±0.05mm	±0.01mm
Ball screw lead	21 mm (lead converted into ball screw)	21 mm (lead converted into ball screw)	5mm
Motor output	200W	200W	100 W, with brake
Resolution	0.01mm		

Acceleration/deceleration time when the maximum speed is set: 0.4 sec. or over

Maximum Payload (kg)	Z-axis stroke	Y-axis stroke									
		100mm	200mm	300mm	400mm	500mm	600mm	700mm	800mm	900mm	1000mm
	100mm	14.0	13.0	12.0	11.0	9.0	8.0	6.0	6.0	5.0	4.0
	200mm	13.0	12.0	11.0	10.0	8.0	7.0	6.0	6.0	5.0	4.0
	300mm	13.0	12.0	11.0	9.0	7.0	6.0	5.0	5.0	4.0	3.0

**R: Right-handed**

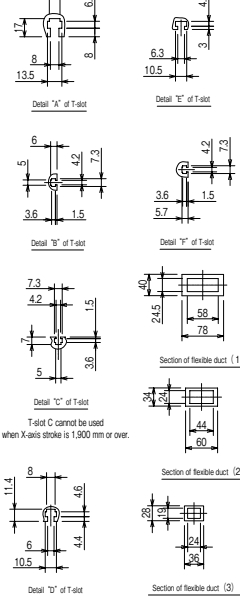

The values in parentheses are applicable when the X-axis stroke is 1,900 mm or over.

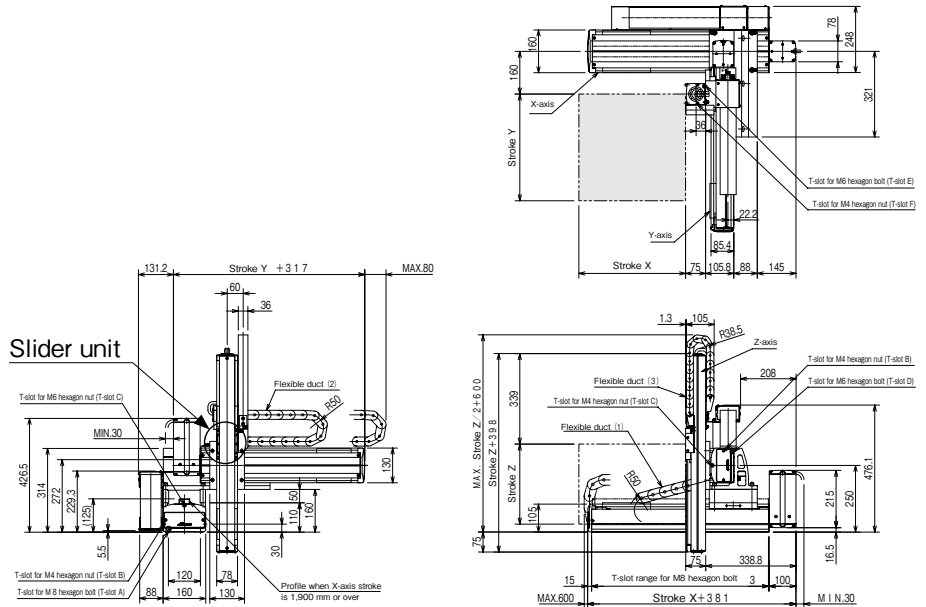

**L: Left-handed**

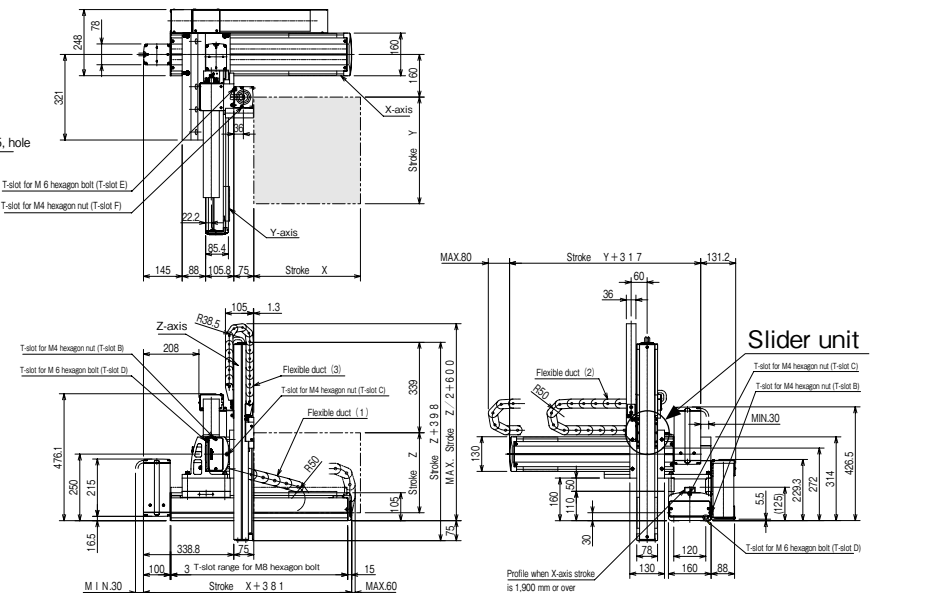
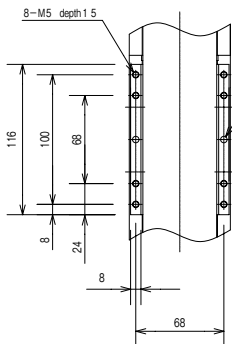

X-Y-Z Flexible-duct Spec.

[Set designation]

BA2 – A5 – A4R A – 40 45 30 – RF 2 3

Harmonic drive type

X-axis: Ball screw driven Motor straight  
 Y-axis: Ball screw driven Motor straight  
 Z-axis: Ball screw driven Motor straight  
 R-axis: Harmonic drive

Combined operation R: Right-handed L: Left-handed	Axis 1 stroke 20 : 200mm 90 : 900mm A0 : 1000mm F0 : 1500mm	Axis 2 stroke 15 : 150mm 95 : 950mm A5 : 1050mm	Axis 3 stroke 10 : 100mm 30 : 300mm	Controller 0: None 1: CA20-M10 2: CA10-M00B 3: CA10-M01B	Cable length 3 : 3m 9 : 9m 5 : 5m B : 11m 7 : 7m D : 13m
---	---	--	---	--	---

Note 1: When the stroke is as given below, the maximum speed differs.

[Specifications]

	X-axis	Y-axis	Z-axis	R-axis
Type of axis	BB50F-ST-M20N-□0	BB30E-ST-M12N-□5	BB10E-ST-M05B-□0	BB00D-RH-A
Stroke (in increments of 100 mm)	200 ~ 1500mm	150 ~ 1050mm	100 ~ 300mm	360°
Maximum speed	1,200 mm/s (Note 1)	1,200 mm/s (Note 1)	300mm/s	360°/s
Positioning repeatability	±0.01mm	±0.01mm	±0.01mm	±0.025°
Ball screw lead	20mm	20mm	5mm	1/50 (Reduction ratio)
Motor output	200W	100W	100 W, with brake	50W
Resolution	0.01 mm (R-axis: 0.01 deg.)			

Acceleration/deceleration time when the maximum speed is set: 0.36 sec. or over

	Stroke (mm)	Maximum speed (mm/s)
X-axis	700 ~ 800	1100
	900 ~ 1000	1000
	1100 ~ 1200	700
	1300	500
	1400	400
Y-axis	1500	300
	750	1000
	850	800
	950 ~ 1050	600

Maximum Payload (kg)	Y-axis stroke										
	150mm	250mm	350mm	450mm	550mm	650mm	750mm	850mm	950mm	1050mm	
Z-axis stroke	100mm	5.0	5.0	5.0	5.0	5.0	5.0	5.0	5.0	5.0	3.0
	200mm	5.0	5.0	5.0	5.0	5.0	5.0	5.0	5.0	4.0	2.0
	300mm	5.0	5.0	5.0	5.0	5.0	5.0	5.0	5.0	4.0	1.0

R: Right-handed

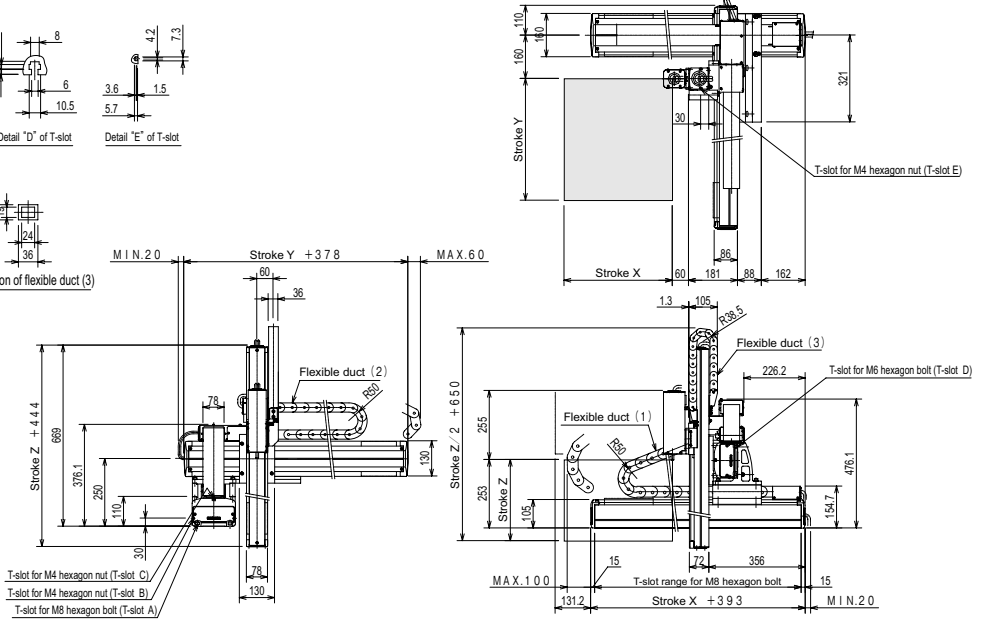
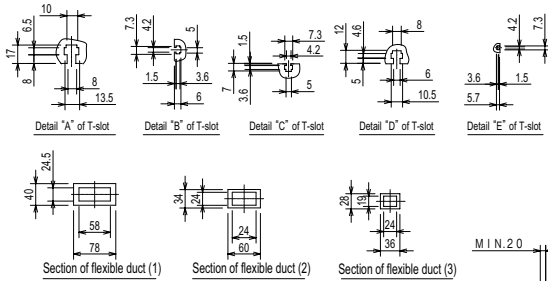

L: Left-handed

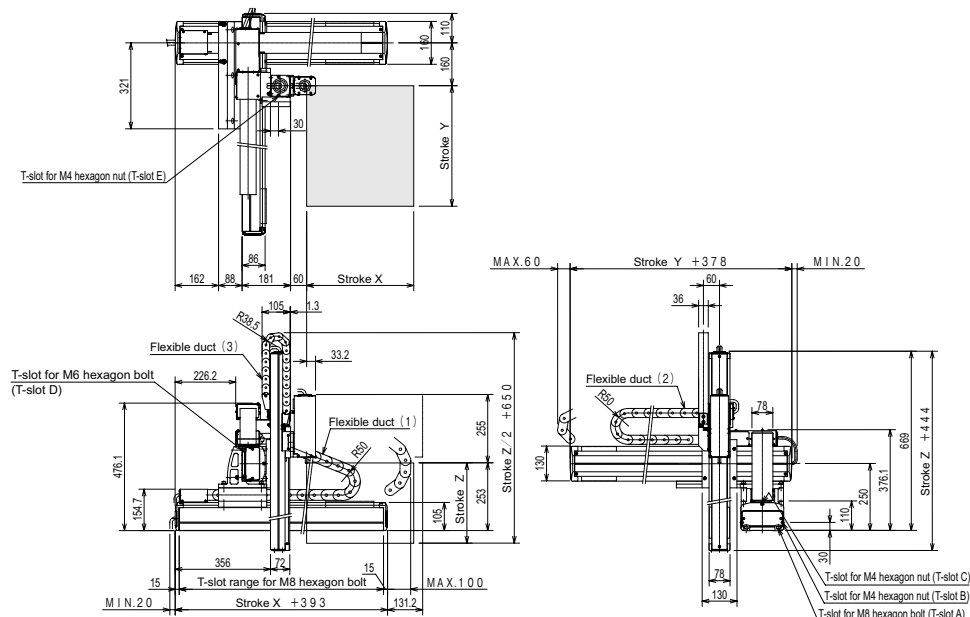
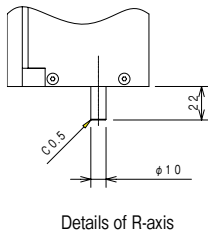

X-Y-Z-R Flexible-duct Spec.

[Set designation]

**BA2 – A5 – A4A R G – 40 45 30 – RF 2 3**

**Harmonic drive type**

X-axis: Ball screw driven Side mounted motor  
 Y-axis: Ball screw driven Motor straight  
 Z-axis: Ball screw driven Motor straight  
 R-axis: Harmonic drive

Combined operation R: Right-handed L: Left-handed	Axis 1 stroke 20 : 200mm 90 : 900mm A0 : 1000mm F0 : 1500mm	Axis 2 stroke 15 : 150mm 95 : 950mm A5 : 1050mm	Axis 3 stroke 10 : 100mm 30 : 300mm	Controller 0: None 1 : CA20-M10 2 : CA10-M00B 3 : CA10-M01B	Cable length 3 : 3m 9 : 9m 5 : 5m B : 11m 7 : 7m D : 13m
---	---	--	---	---	---

Note 1: When the stroke is as given below, the maximum speed differs.

[Specifications]

	X-axis	Y-axis	Z-axis	R-axis
Type of axis	BB50F-U □ -M20N- □ 0	BB30E-ST-M20N- □ 5	BB10E-ST-M05B □ 0	BA00D-RH-A
Stroke (in increments of 100 mm)	200 ~ 1500mm	150 ~ 1050mm	100 ~ 300mm	360°
Maximum speed	1,200 mm/s (Note 1)	1,200 mm/s (Note 1)	300mm/s	360°/s
Positioning repeatability	±0.01mm	±0.01mm	±0.01mm	±0.025°
Ball screw lead	20mm	20mm	5mm	1/50 (Reduction ratio)
Motor output	200W	100W	100 W, with brake	50W
Resolution	0.01 mm (R-axis: 0.01 deg.)			

Acceleration/deceleration time when the maximum speed is set: 0.36 sec. or over

	Stroke (mm)	Maximum speed (mm/s)
X-axis	700 ~ 800	1100
	900 ~ 1000	1000
	1100 ~ 1200	700
	1300	500
	1400	400
Y-axis	1500	300
	750	1000
	850	800
	950 ~ 1050	600

Maximum Payload (kg)	Y-axis stroke										
	150mm	250mm	350mm	450mm	550mm	650mm	750mm	850mm	950mm	1050mm	
Z-axis stroke	100mm	5.0	5.0	5.0	5.0	5.0	5.0	5.0	5.0	5.0	3.0
	200mm	5.0	5.0	5.0	5.0	5.0	5.0	5.0	5.0	4.0	2.0
	300mm	5.0	5.0	5.0	5.0	5.0	5.0	5.0	5.0	4.0	1.0

**R: Right-handed**

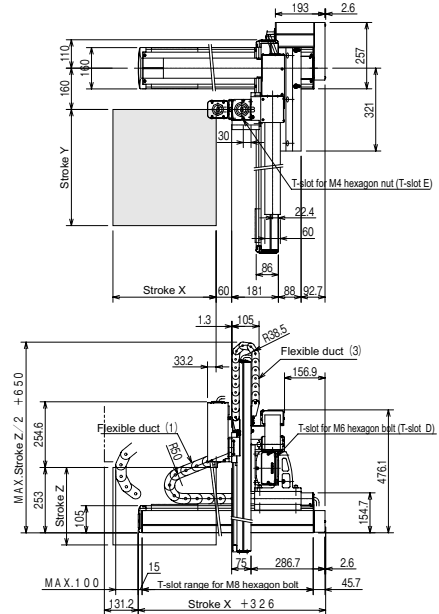
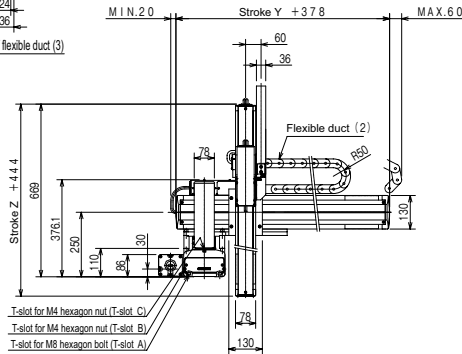
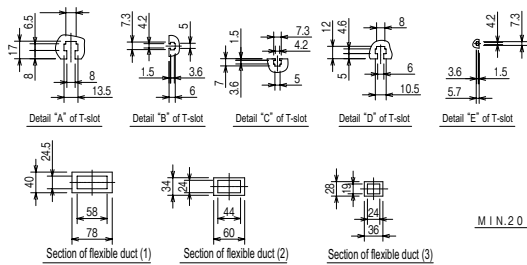

**L: Left-handed**

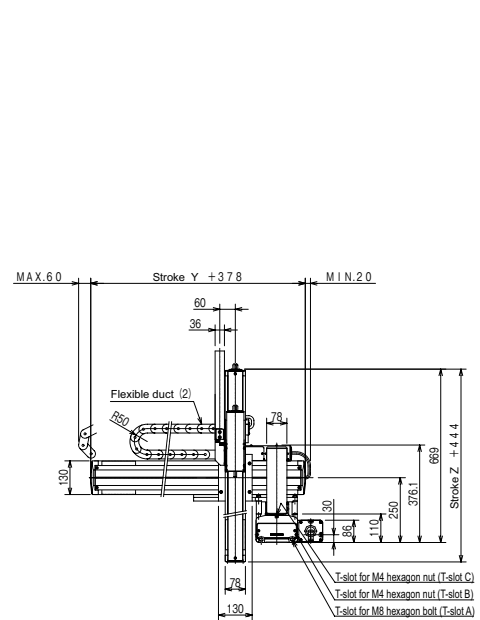
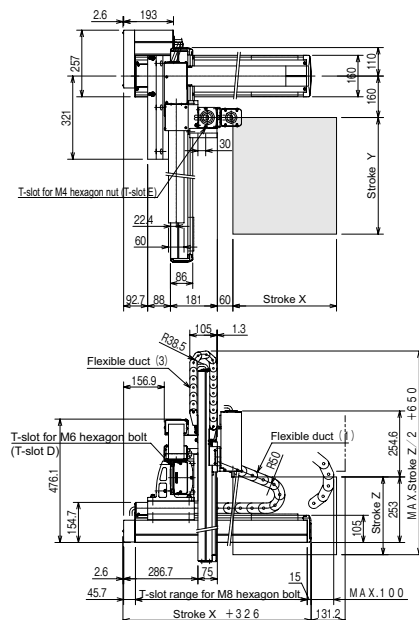
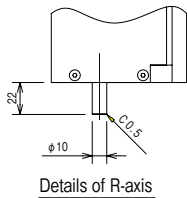

X-Y-Z-R Flexible-duct Spec., Space-saving type

[Set designation]

**BA2 - A5 - A4B R A - 40 40 30 - RF 2 3**

Harmonic drive type

X-axis: Ball screw driven Motor straight  
 Y-axis: Ball screw driven Motor straight  
 Z-axis: Ball screw driven Motor straight  
 R-axis: Harmonic drive

Combined operation R: Right-handed L: Left-handed	Axis 1 stroke 20 : 200mm 90 : 900mm A0 : 1000mm F0 : 1500mm	Axis 2 stroke 10 : 100mm 90 : 900mm A0 : 1000mm	Axis 3 stroke 10 : 100mm 30 : 300mm	Controller 0: None 1 : CA20-M10 2 : CA10-M00B 3 : CA10-M01B	Cable length 3 : 3m 9 : 9m 5 : 5m B : 11m 7 : 7m D : 13m
---	---	--	---	---	---

Note 1: When the stroke is as given below, the maximum speed differs.

	Stroke (mm)	Maximum speed (mm/s)
X-axis	700 ~ 800	1100
	900 ~ 1000	1000
	1100 ~ 1200	700
	1300	500
	1400	400
Y-axis	1500	300
	700	1000
	8500	800
	900 ~ 1000	600

[Specifications]

	X-axis	Y-axis	Z-axis	R-axis
Type of axis	BB50F-ST-M20N-□0	BB30F-ST-M20N-□0	BB10E-ST-M05B-□0	BB00D-RH-A
Stroke (in increments of 100 mm)	200 ~ 1500mm	100 ~ 1000mm	100 ~ 300mm	360°
Maximum speed	1,200 mm/s (Note 1)	1,200 mm/s (Note 1)	300mm/s	360°/s
Positioning repeatability	±0.01mm	±0.01mm	±0.01mm	±0.025°
Ball screw lead	20mm	20mm	5mm	1/50 (Reduction ratio)
Motor output	200W	200W	100 W, with brake	50W
Resolution	0.01 mm (R-axis: 0.01 deg.)			

Acceleration/deceleration time when the maximum speed is set: 0.36 sec. or over

Maximum Payload (kg)	Y-axis stroke									
	150mm	250mm	350mm	450mm	550mm	650mm	750mm	850mm	950mm	1050mm
Z-axis stroke	100mm	5.0	5.0	5.0	5.0	5.0	5.0	5.0	5.0	3.0
	200mm	5.0	5.0	5.0	5.0	5.0	5.0	5.0	5.0	2.0
	300mm	5.0	5.0	5.0	5.0	5.0	5.0	5.0	5.0	1.0

R: Right-handed

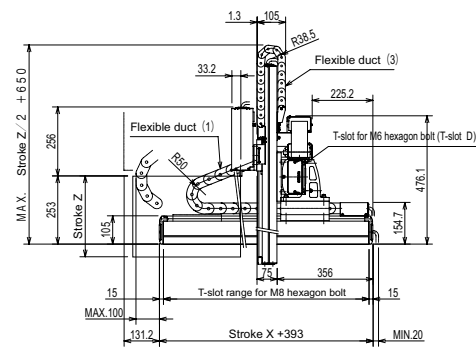
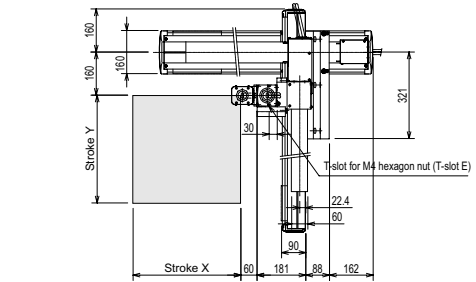
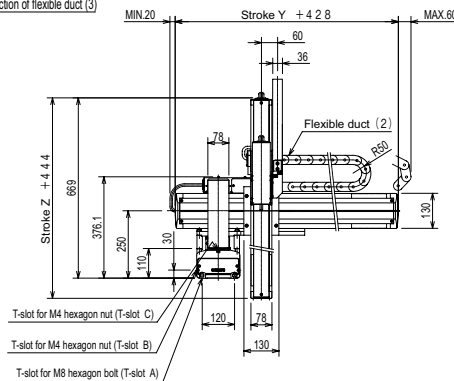
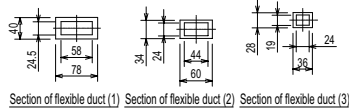
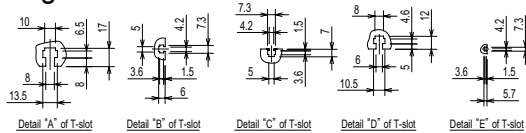

L: Left-handed

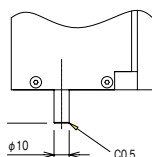

Details of R-axis

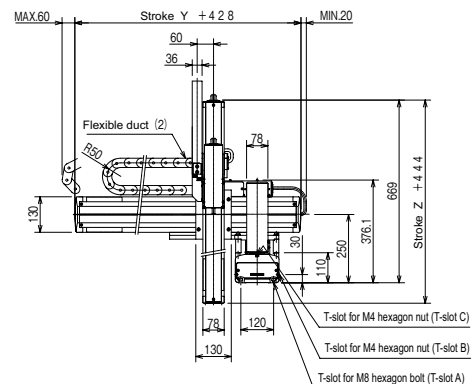
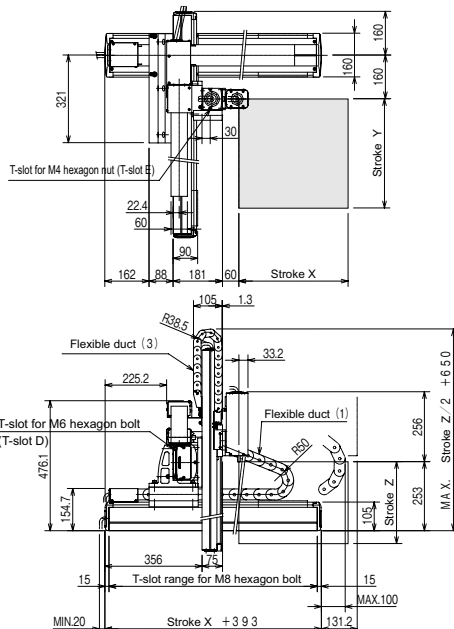

X-Y-Z-R Flexible-duct Spec.

[Set designation]

**BA2 – A5 – A4B R G – 40 40 30 – RF 2 3**

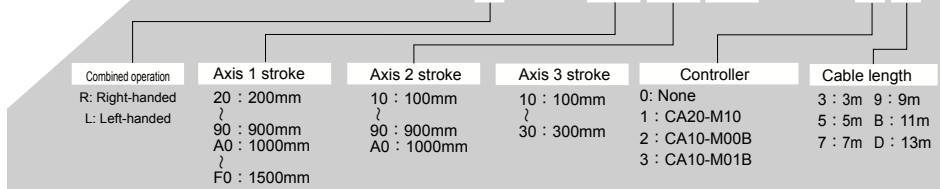

**Harmonic drive type**

X-axis: Ball screw driven Side mounted motor  
Y-axis: Ball screw driven Motor straight  
Z-axis: Ball screw driven Motor straight  
R-axis: Harmonic drive

Note 1: When the stroke is as given below, the maximum speed differs.

[Specifications]

	X-axis	Y-axis	Z-axis	R-axis
Type of axis	BB50F-U □ -M20N- □ 0	BB30F-ST-M20N- □ 0	BB10E-ST-M05B- □ 0	BB00D-RH-A
Stroke (in increments of 100 mm)	200 ~ 1500mm	100 ~ 1000mm	100 ~ 300mm	360°
Maximum speed	1,200 mm/s (Note 1)	1,200 mm/s (Note 1)	300mm/s	360°/s
Positioning repeatability	±0.01mm	±0.01mm	±0.01mm	±0.025°
Ball screw lead	20mm	20mm	5mm	1/50 (Reduction ratio)
Motor output	200W	200W	100 W, with brake	50W
Resolution	0.01 mm (R-axis: 0.01 deg.)			

Acceleration/deceleration time when the maximum speed is set: 0.36 sec. or over

	Stroke (mm)	Maximum speed (mm/s)
X-axis	700 ~ 800	1100
	900 ~ 1000	1000
	1100 ~ 1200	700
	1300	500
	1400	400
Y-axis	1500	300
	700	1000
	8500	800
	900 ~ 1000	600

Maximum Payload (kg)	Y-axis stroke									
	100mm	200mm	300mm	400mm	500mm	600mm	700mm	800mm	900mm	1000mm
Z-axis stroke	100mm	5.0	5.0	5.0	5.0	5.0	5.0	5.0	5.0	3.0
	200mm	5.0	5.0	5.0	5.0	5.0	5.0	5.0	5.0	2.0
	300mm	5.0	5.0	5.0	5.0	5.0	5.0	5.0	5.0	1.0

**R: Right-handed**

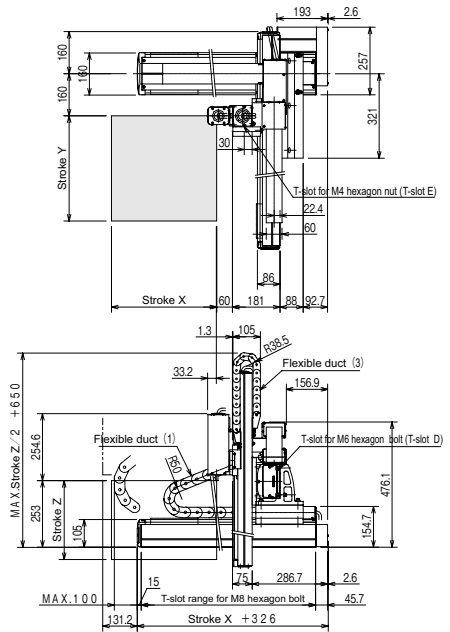
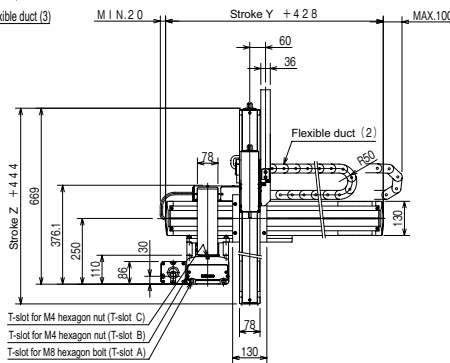
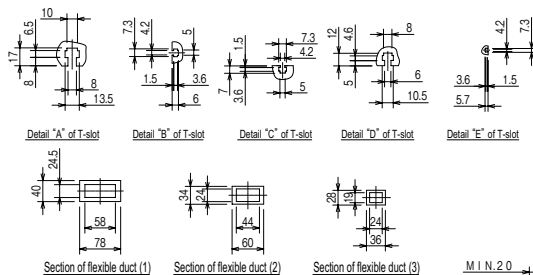

**L: Left-handed**

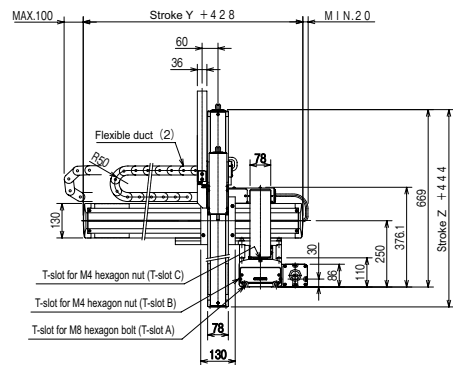
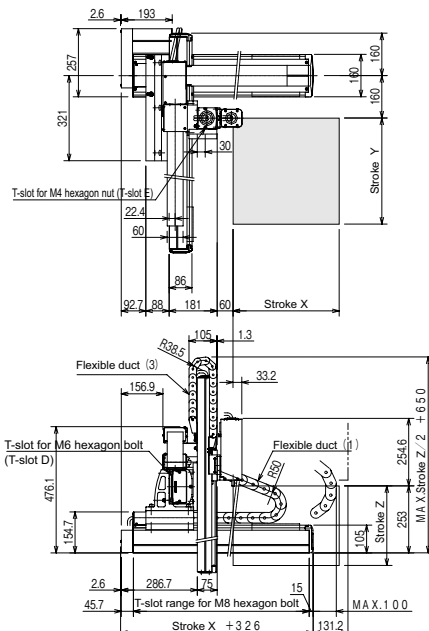
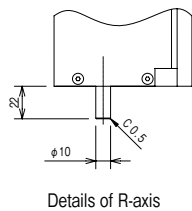

X-Y-Z-R Flexible-duct Spec., Space-saving type



[Set designation]

**BA2 – A5 – A4R A – 40 45 30 – UF 2 3**

Planet gear type

X-axis: Ball screw driven Motor straight  
 Y-axis: Ball screw driven Motor straight  
 Z-axis: Ball screw driven Motor straight  
 R-axis: Planet gear

Combined operation R: Right-handed L: Left-handed	Axis 1 stroke 20 : 200mm 90 : 900mm A0 : 1000mm F0 : 1500mm	Axis 2 stroke 15 : 150mm 95 : 950mm A5 : 1050mm	Axis 3 stroke 10 : 100mm 30 : 300mm	Controller 0 : None 1 : CA20-M10 2 : CA10-M00B 3 : CA10-M01B	Cable length 3 : 3m 9 : 9m 5 : 5m B : 11m 7 : 7m D : 13m
---	---	--	---	--	---

Note 1: When the stroke is as given below, the maximum speed differs.

[Specifications]

	X-axis	Y-axis	Z-axis	R-axis
Type of axis	BB50F-ST-M20N-□ 0	BB30E-ST-M20N-□ 5	BB10E-ST-M05B-□ 0	BB00D-RP-A
Stroke (in increments of 100 mm)	200 ~ 1500mm	150 ~ 1050mm	100 ~ 300mm	360°
Maximum speed	1,200 mm/s (Note 1)	1,200 mm/s (Note 1)	300mm/s	857°/s
Positioning repeatability	±0.01mm	±0.01mm	±0.01mm	±0.125°
Ball screw lead	20mm	20mm	5mm	1/21 (Reduction ratio)
Motor output	200W	100W	100 W, with brake	50W
Resolution	0.01 mm (R-axis: 0.01 deg.)			

	Stroke (mm)	Maximum speed (mm/s)
X-axis	700 ~ 800	1100
	900 ~ 1000	1000
	1100 ~ 1200	700
	1300	500
	1400	400
Y-axis	1500	300
	750	1000
	850	800
	950 ~ 1050	600

Acceleration/deceleration time when the maximum speed is set: 0.36 sec. or over

Maximum Payload (kg)	Y-axis stroke										
	150mm	250mm	350mm	450mm	550mm	650mm	750mm	850mm	950mm	1050mm	
Z-axis stroke	100mm	8.0	8.0	8.0	8.0	8.0	8.0	8.0	7.0	5.0	3.0
	200mm	6.0	6.0	6.0	6.0	6.0	6.0	6.0	6.0	4.0	2.0
	300mm	5.0	5.0	5.0	5.0	5.0	5.0	5.0	5.0	4.0	1.0

R: Right-handed

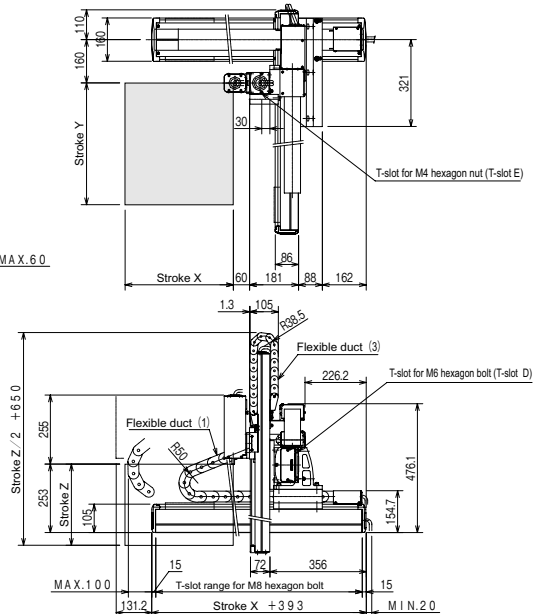
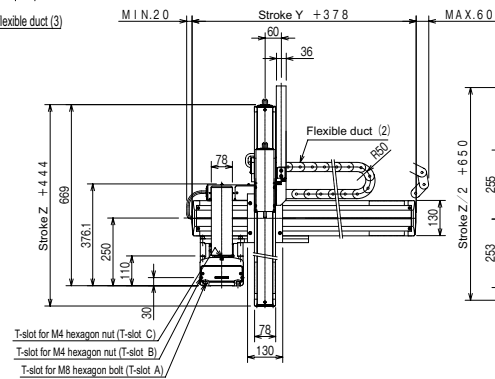
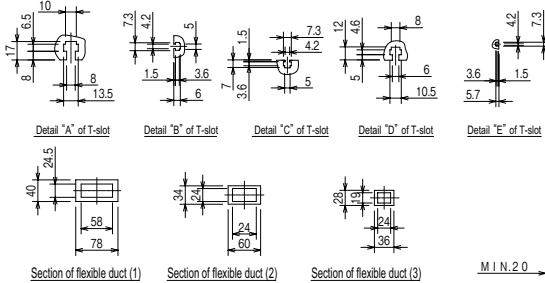

L: Left-handed

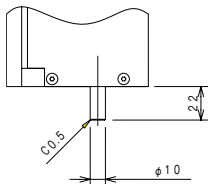

Details of R-axis

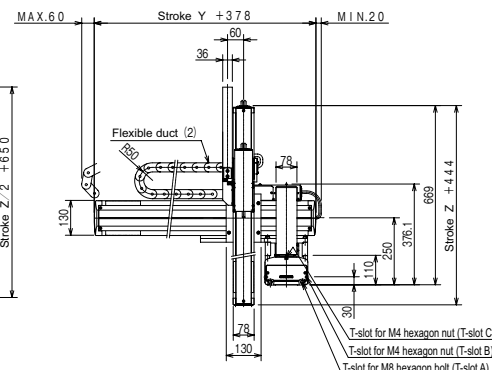
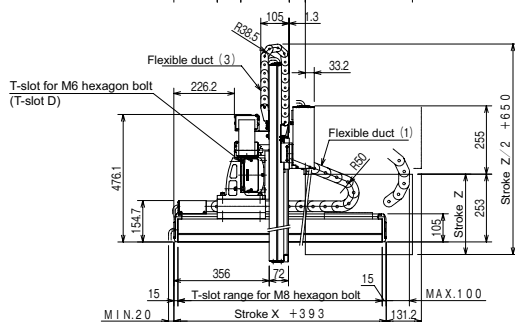
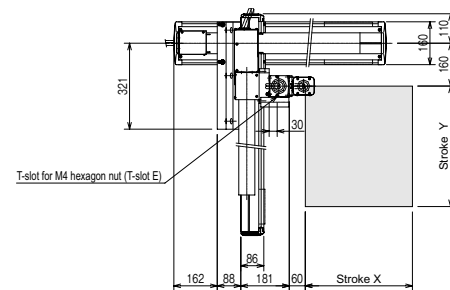

X-Y-Z-R Flexible-duct Spec.

[Set designation]

**BA2 – A5 – A4A R G – 40 45 30 – UF 2 3**

Combined operation R: Right-handed L: Left-handed	Axis 1 stroke 20 : 200mm 90 : 900mm A0 : 1000mm F0 : 1500mm	Axis 2 stroke 15 : 150mm 95 : 950mm A5 : 1050mm	Axis 3 stroke 10 : 100mm 30 : 300mm	Controller 0: None 1 : CA20-M10 2 : CA10-M00B 3 : CA10-M01B	Cable length 3 : 3m 9 : 9m 5 : 5m B : 11m 7 : 7m D : 13m
---	---	--	---	---	---

**Planet gear type**

X-axis: Ball screw driven Side mounted motor  
Y-axis: Ball screw driven Motor straight  
Z-axis: Ball screw driven Motor straight  
R-axis: Planet gear

Note 1: When the stroke is as given below, the maximum speed differs.

	Stroke (mm)	Maximum speed (mm/s)
X-axis	700 ~ 800	1100
	900 ~ 1000	1000
	1100 ~ 1200	700
	1300	500
	1400	400
Y-axis	1500	300
	750	1000
	850	800
	950 ~ 1050	600

[Specifications]

	X-axis	Y-axis	Z-axis	R-axis
Type of axis	BB50F-U □ -M20N- □ 0	BB30E-ST-M20N- □ 5	BB10E-ST-M05B- □ 0	BB00D-RP-A
Stroke (in increments of 100 mm)	200 ~ 1500mm	150 ~ 1050mm	100 ~ 300mm	360°
Maximum speed	1,200 mm/s (Note 1)	1,200 mm/s (Note 1)	300mm/s	857/s
Positioning repeatability	±0.01mm	±0.01mm	±0.01mm	±0.125°
Ball screw lead	20mm	20mm	5mm	1/21 (Reduction ratio)
Motor output	200W	100W	100 W, with brake	50W
Resolution	0.01 mm (R-axis: 0.01 deg.)			

Acceleration/deceleration time when the maximum speed is set: 0.36 sec. or over

Maximum Payload (kg)	Y-axis stroke										
	150mm	250mm	350mm	450mm	550mm	650mm	750mm	850mm	950mm	1050mm	
Z-axis stroke	100mm	8.0	8.0	8.0	8.0	8.0	8.0	8.0	7.0	5.0	3.0
	200mm	6.0	6.0	6.0	6.0	6.0	6.0	6.0	6.0	4.0	2.0
	300mm	5.0	5.0	5.0	5.0	5.0	5.0	5.0	5.0	4.0	1.0

**R: Right-handed**

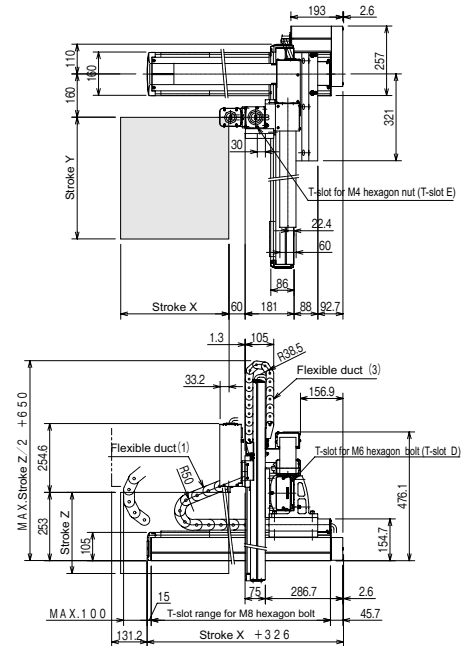
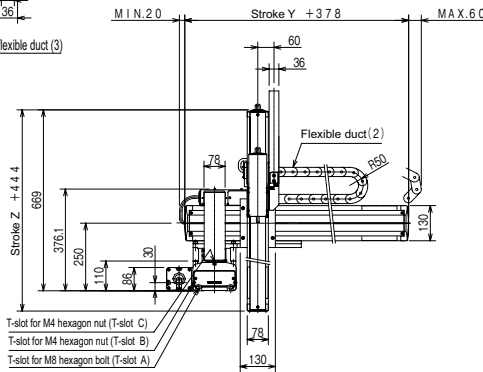
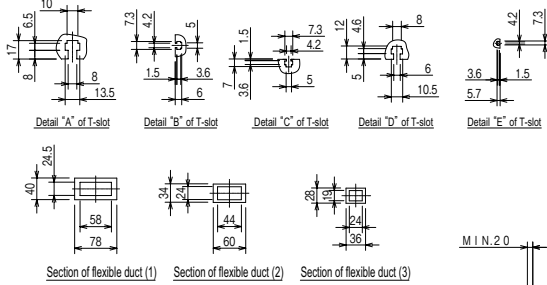

**L: Left-handed**

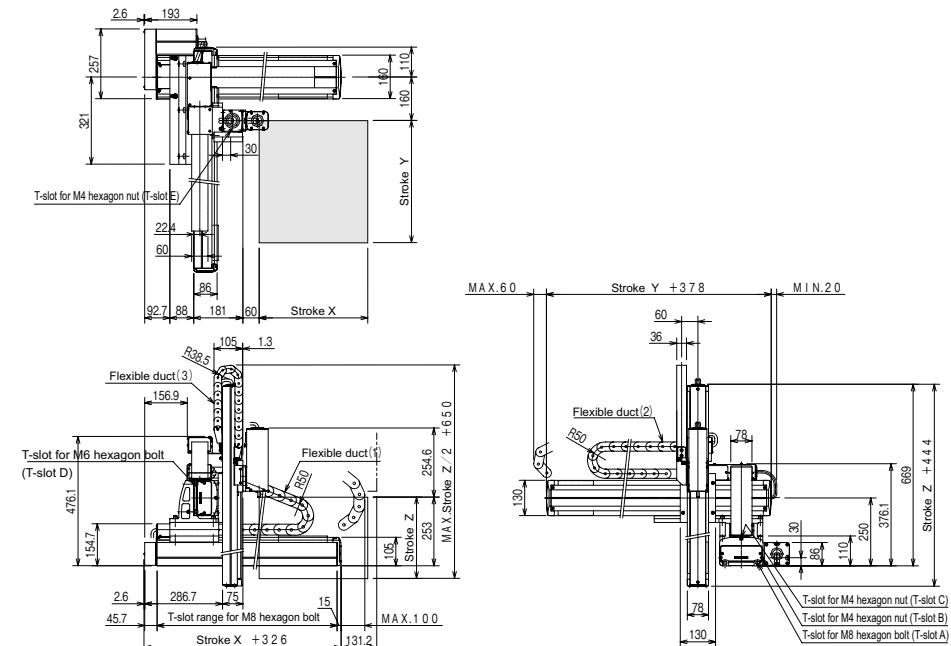
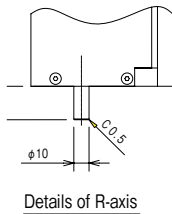

[Set designation]

**BA2 – A5 – A4B R A – 40 40 30 – UF 2 3**

Planet gear type

X-axis: Ball screw driven Motor straight  
 Y-axis: Ball screw driven Motor straight  
 Z-axis: Ball screw driven Motor straight  
 R-axis: Planet gear

Combined operation R: Right-handed L: Left-handed	Axis 1 stroke 20 : 200mm 90 : 900mm A0 : 1000mm F0 : 1500mm	Axis 2 stroke 10 : 100mm 90 : 900mm A0 : 1000mm	Axis 3 stroke 10 : 100mm 30 : 300mm	Controller 0 : None 1 : CA20-M10 2 : CA10-M00B 3 : CA10-M01B	Cable length 3 : 3m 9 : 9m 5 : 5m B : 11m 7 : 7m D : 13m
---	---	--	---	--	---

Note 1: When the stroke is as given below, the maximum speed differs.

[Specifications]

	X-axis	Y-axis	Z-axis	R-axis
Type of axis	BB50F-ST-M20N-□0	BB30F-ST-M20N-□0	BB10E-ST-M05B-□0	BB00D-RP-A
Stroke (in increments of 100 mm)	200 ~ 1500mm	100 ~ 1000mm	100 ~ 300mm	360°
Maximum speed	1,200 mm/s (Note 1)	1,200 mm/s (Note 1)	300mm/s	857°/s
Positioning repeatability	±0.01mm	±0.01mm	±0.01mm	±0.025°
Ball screw lead	20mm	20mm	5mm	1/21 (Reduction ratio)
Motor output	200W	200W	100 W, with brake	50W
Resolution	0.01 mm (R-axis: 0.01 deg.)			

Acceleration/deceleration time when the maximum speed is set: 0.36 sec. or over

	Stroke (mm)	Maximum speed (mm/s)
X-axis	700 ~ 800	1100
	900 ~ 1000	1000
	1100 ~ 1200	700
	1300	500
	1400	400
Y-axis	1500	300
	700	1000
	8500	800
	900 ~ 1000	600

Maximum Payload (kg)		Y-axis stroke									
		100mm	200mm	300mm	400mm	500mm	600mm	700mm	800mm	900mm	1000mm
Z-axis stroke	100mm	10.0	10.0	10.0	10.0	10.0	10.0	10.0	8.0	5.0	3.0
	200mm	10.0	10.0	10.0	10.0	10.0	10.0	10.0	7.0	5.0	2.0
	300mm	10.0	10.0	10.0	10.0	10.0	10.0	10.0	7.0	4.0	2.0

R: Right-handed

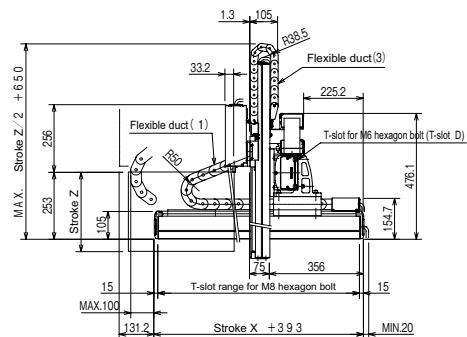
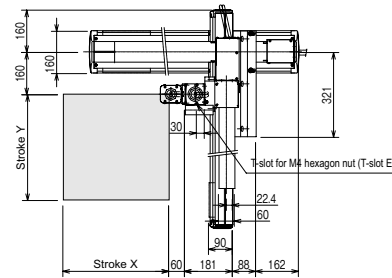
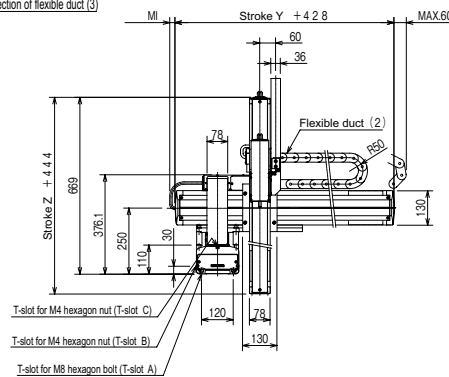
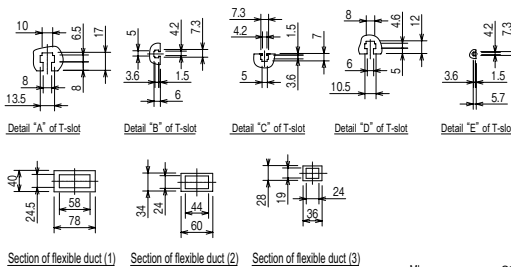

L: Left-handed

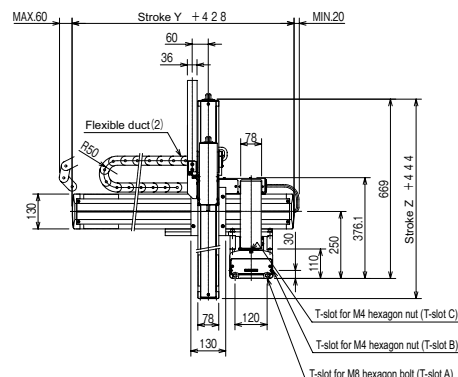
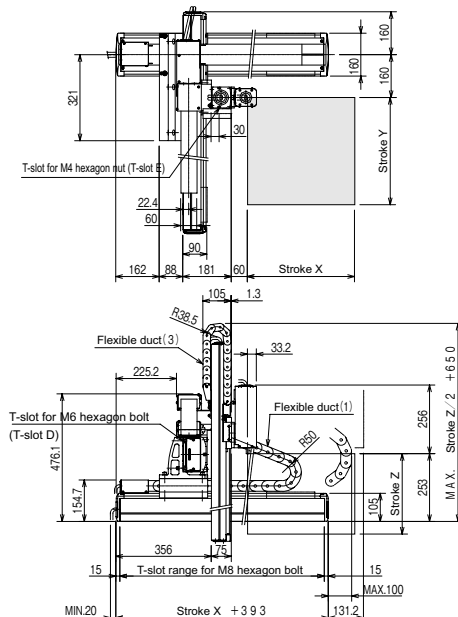
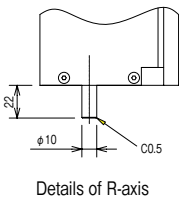

X-Y-Z-R Flexible-duct Spec.

[Set designation]

**BA2 – A5 – A4B R G – 40 40 30 – UF 2 3**

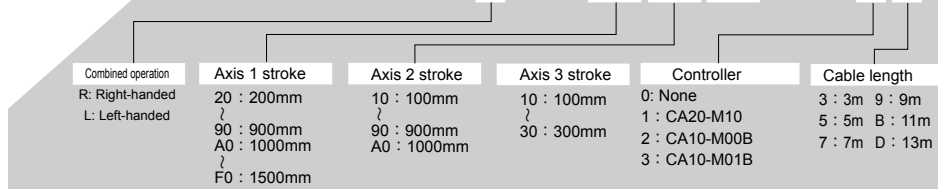

**Planet gear type**

X-axis: Ball screw driven Side mounted motor  
Y-axis: Ball screw driven Motor straight  
Z-axis: Ball screw driven Motor straight  
R-axis: Planet gear

Note 1: When the stroke is as given below, the maximum speed differs.

	Stroke (mm)	Maximum speed (mm/s)
X-axis	700 ~ 800	1100
	900 ~ 1000	1000
	1100 ~ 1200	700
	1300	500
	1400	400
Y-axis	1500	300
	700	1000
	8500	800
	900 ~ 1000	600

**[Specifications]**

	X-axis	Y-axis	Z-axis	R-axis
Type of axis	BB50F-U-M20N-□0	BB30F-ST-M20N-□0	BB10E-ST-M05B-□0	BB00D-RP-A
Stroke (in increments of 100 mm)	200 ~ 1500mm	100 ~ 1000mm	100 ~ 300mm	360°
Maximum speed	1,200 mm/s (Note 1)	1,200 mm/s (Note 1)	300mm/s	857/s
Positioning repeatability	±0.01mm	±0.01mm	±0.01mm	±0.125°
Ball screw lead	20mm	20mm	5mm	1/21 (Reduction ratio)
Motor output	200W	200W	100 W, with brake	50W
Resolution	0.01 mm (R-axis: 0.01 deg.)			

Acceleration/deceleration time when the maximum speed is set: 0.36 sec. or over

Maximum Payload (kg)	Y-axis stroke									
	100mm	200mm	300mm	400mm	500mm	600mm	700mm	800mm	900mm	1000mm
Z-axis stroke	10.0	10.0	10.0	10.0	10.0	10.0	10.0	8.0	5.0	3.0
	10.0	10.0	10.0	10.0	10.0	10.0	10.0	7.0	5.0	2.0
	10.0	10.0	10.0	10.0	10.0	10.0	10.0	7.0	4.0	2.0

**R: Right-handed**

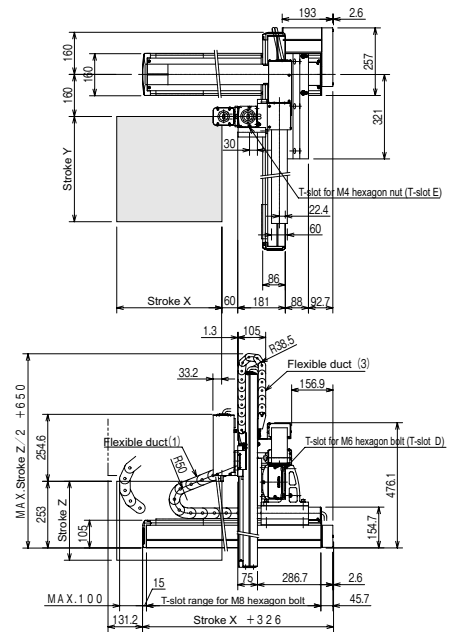
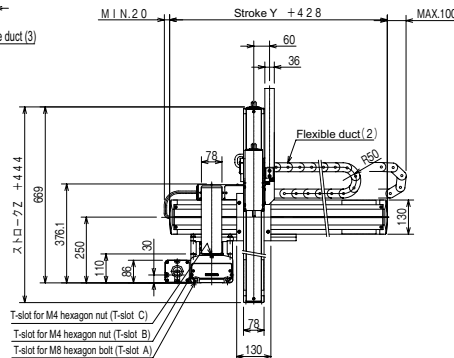
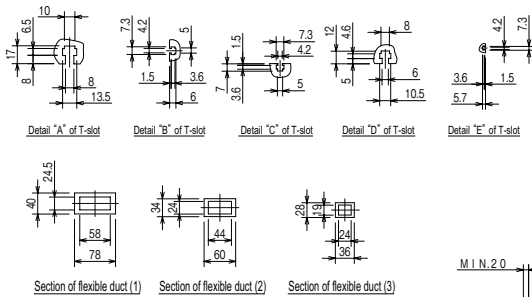

**L: Left-handed**

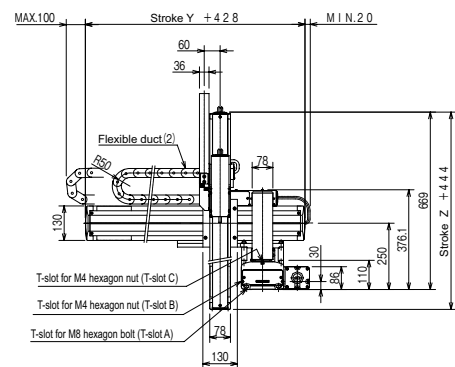
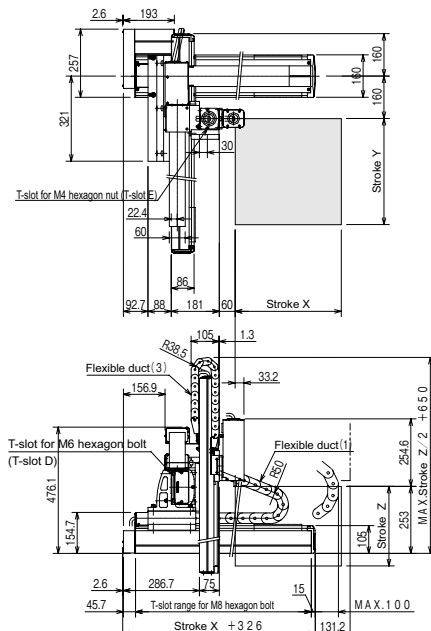
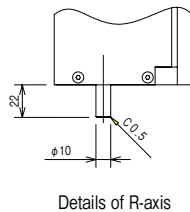

X-Y-Z-R Flexible-duct Spec., Space-saving type

# Variations

Simple Dust-Resistant Axes Specifications ...	172
Cleanroom Axis Specifications .....	174

# Simple Dust-Resistant Axes Specifications

Simple dust-resistant axes with provisions for preventing entry of contaminant into axes. They protect the ball screws and linear guides from a dusty working environment.

## [Features]

- Designed based on the standard axes. Long service life can be assured by the construction of the bellows.
- Enhanced sealing ability against dust at air-purging.
- Both straight axis and side mounted motor axis are available to serve each user's installation space.
- The side mounted motor axis comes in three types; right side mounted motor axis, left side mounted motor axis and bottom side mounted motor axis.
- Each axis can be mounted horizontally by facing up or sideways, or mounted vertically.
- Compliant to IP standard (IP30) for dust-resistance and water-proofing.

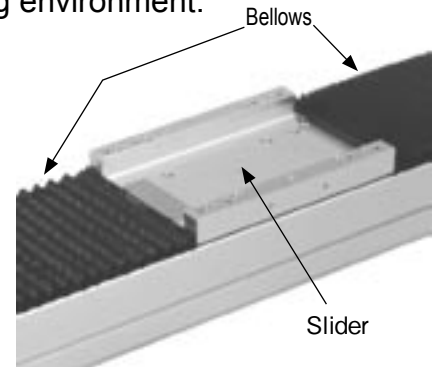

## Simple dust-resistant axis BB10

The specifications other than outer dimensions are the same as those of the BB10 standard axis. See Pages 22 ~ 23.

[Code designation]

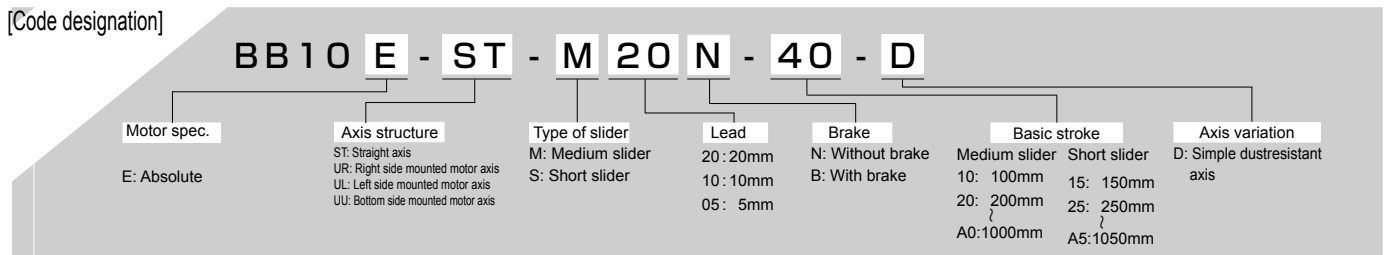

• Specify the basic stroke.

[Dimensions] Motor straight axis

For the dimensions of other axis structures, consult with our sales office in your territory.

### BB10E-ST

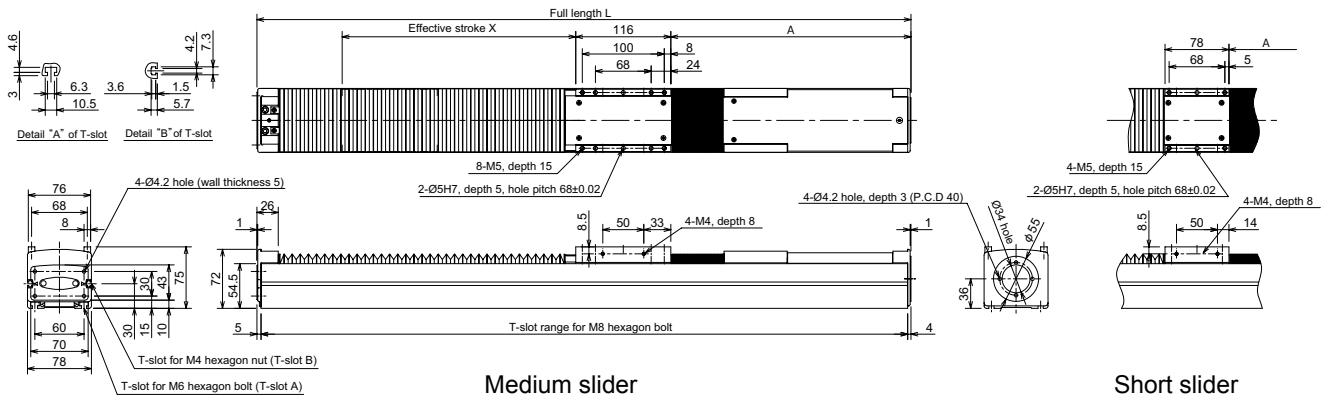

Medium slider

Basic stroke (mm)	100	200	300	400	500	600	700	800	900	1000
Effective stroke X (mm)	65	133	217	285	369	453	521	605	673	757
L (mm)	Without brake	498	598	698	798	898	998	1098	1198	1298
	With brake	540	640	740	840	940	1040	1140	1240	1340
A (mm)	Without brake	253	269	277	293	301	309	325	333	349
	With brake	295	311	319	335	343	351	367	375	391

Short slider

Basic stroke (mm)	150	250	350	450	550	650	750	850	950	1050
Effective stroke X (mm)	99	183	251	335	403	487	555	639	707	791
L (mm)	Without brake	498	598	698	798	898	998	1098	1198	1298
	With brake	540	640	740	840	940	1040	1140	1240	1340
A (mm)	Without brake	261	269	285	293	309	317	333	341	357
	With brake	303	311	327	335	351	359	375	383	399

## Simple dust-resistant axis BB30

The specifications other than outer dimensions are the same as those of the BB30 standard axis. See Pages 24 ~ 27.

[Code designation]

**BB30 E - ST - M 20 N - 40 - D**

<b>Motor spec.</b> E: Absolute 100W F: Absolute 200W	<b>Axis structure</b> ST: Straight axis UR: Right side mounted motor axis UL: Left side mounted motor axis UU: Bottom side mounted motor axis	<b>Type of slider</b> M: Medium slider L: Long slider	<b>Lead</b> 20: 20mm 10: 10mm 05: 5mm	<b>Brake</b> N: Without brake B: With brake	<b>Basic stroke</b> * See the basic stroke of the standard axis.	<b>Axis variation</b> D: Simple dust-resistant axis
--	---	---	--	---	---	--

• Specify the basic stroke.

### [Dimensions] Motor straight axis

For the dimensions of other axis structures, consult with our sales agent in your territory.

**BB30E-ST**

**Medium slider**

Basic stroke (mm)		150	250	350	450	550	650	750	850	950	1050
Effective stroke (mm)		150	250	350	450	550	650	750	850	950	1050
L (mm)	Without brake	536	651	765	879	993	1107	1222	1336	1450	1570
	With brake	576	691	805	919	1033	1147	1262	1376	1490	1604
A (mm)	Without brake	194	194	194	194	194	194	194	194	194	200
	With brake	234	234	234	234	234	234	234	234	234	234

**Long slider**

Basic stroke (mm)		150	250	350	450	550	650	750	850	950	1050
Effective stroke (mm)		150	250	350	450	550	650	750	850	950	1050
L (mm)	Without brake	536	651	765	879	993	1107	1222	1336	1484	1612
	With brake	576	691	805	919	1033	1147	1262	1376	1490	1612
A (mm)	Without brake	144	144	144	144	144	144	150	164	178	192
	With brake	184	184	184	184	184	184	184	184	184	192

## Simple dust-resistant axis BB50

The specifications other than outer dimensions are the same as those of the BB50 standard axis. See Pages 28 ~ 31.

[Code designation]

**BB50 F - ST - M 20 N - 40 - D**

<b>Motor spec.</b> F: Absolute 200W G: Absolute 400W	<b>Axis structure</b> ST: Straight axis UR: Right side mounted motor axis UL: Left side mounted motor axis UU: Bottom side mounted motor axis	<b>Type of slider</b> M: Medium slider S: Long slider	<b>Lead</b> 20: 20mm 10: 10mm 05: 5mm	<b>Brake</b> N: Without brake B: With brake	<b>Basic stroke</b> Medium slider 20: 200mm A0: 1000mm F0: 1500mm Long slider 25: 250mm A5: 1050mm E5: 1450mm	<b>Axis variation</b> D: Simple dust-resistant axis
--	---	---	--	---	---	--

• Specify the basic stroke.

### [Dimensions] Motor straight axis

For the dimensions of other axis structures, consult with our sales agent in your territory.

**BB50F-ST**

**Medium slider**

Basic stroke (mm)		200	300	400	500	600	700	800	900	1000	1100	1200	1300	1400	1500
Effective stroke (mm)		200	300	400	500	600	700	800	900	1000	1100	1200	1300	1400	1500
L (mm)	Without brake	597	712	826	940	1054	1168	1286	1414	1542	1666	1784	1914	2042	2170
	With brake	634	749	863	977	1091	1205	1320	1434	1548	1665	1784	1914	2042	2170
A (mm)	Without brake	150	150	150	150	150	150	153	167	181	188	202	217	231	245
	With brake	187	187	187	187	187	187	187	187	187	187	202	217	231	245

**Long slider**

Basic stroke (mm)		250	350	450	550	650	750	850	950	1050	1150	1250	1350	1450
Effective stroke (mm)		250	350	450	550	650	750	850	950	1050	1150	1250	1350	1450
L (mm)	Without brake	705	819	933	1047	1161	1279	1400	1528	1656	1770	1898	2028	2156
	With brake	742	856	970	1084	1198	1313	1427	1541	1655	1770	1898	2028	2156
A (mm)	Without brake	150	150	150	150	150	150	153	160	174	188	195	207	224
	With brake	187	187	187	187	187	187	187	187	187	187	195	209	224

# Cleanroom Axis Specifications

Works in a cleanroom can be done in less space and simplified. Designed for cleanliness "Class 100" (0.3 μm-based).

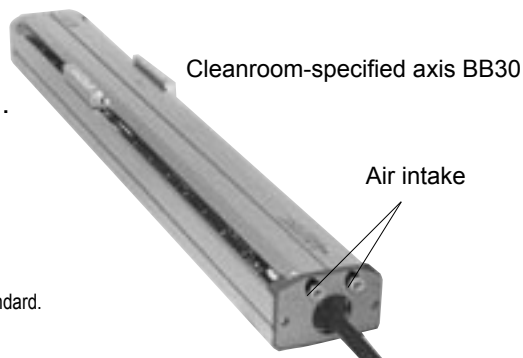

## [Features]

- Cleanness "Class 100" is realized thanks to the use of low-particle grease and air suction in the frame.
- High clean level is achieved by minimum air intake (60 normal liters/min for BB10 straight axis).
- Both straight axis and side mounted motor axis are available to serve each user's installation space as standard.

## [Specifications]

Type of axis <small>(Note 1)</small>		BB10	BB30
Cleanness <small>(Note 2)</small>		Designed for Class 100 (Particle size: 0.3 μm or larger)	
Axis combination		Single axis, or X-Y orthogonal (Cartesian) table type with horizontal slider (facing up).	
Applicable controller		CA20-M10, CA10-M00B, CA20-S10	
Motor		AC servo motor 100W	AC servo motor 100W, 200W
Drive system		Ground ball screw (C7) (15 mm-dia., lead 20, 10, 5 mm)	
Stroke (mm)		100 ~ 1050	
Maximum payload (kg)	Single axis	Same as in standard axis.	Same as in standard axis.
	Cartesian axes	Same as in standard axis.	
Recommended speed (mm/s) <small>(Note 3)</small>	Ball screw lead 20 mm	400 (1200)	
	Ball screw lead 10 mm	200 (600)	
	Ball screw lead 5 mm	100 (300)	
Positioning repeatability (mm) / Resolution (mm)		±0.01 / 0.01	
Surface treatment		Aluminum extruded parts : (Anodized aluminum treatment) Steel plate : (Non-electrolytic nickel plating) Die cast parts : (Non-treatment) ※ 1 Ball screw, guide: (Non-treatment) (Option: RAYDENT treatment) Low-particle grease (rust-preventive grease) (Applied to ball screw, linear guide and ball bearing)	
Grease			
Required air intake (Normal liters/min)	Straight axis	60	150
	Side mounted motor axis	60 (20 inside belt cover)	150 (60 inside belt cover)
Required vacuum pressure (kPa)	Straight axis	21	21
	Side mounted motor axis	21 (5 inside belt cover)	21 (17 inside belt cover)
Air inlet (air tube coupling)	Straight axis	φ 6 mm-dia. (1 place)	φ 10 mm-dia. (2 places)
	Side mounted motor axis	φ 6 mm-dia. (2 places)	φ 12 mm-dia. (1 place), φ 6 mm-dia. (1 place)

Note 1: For details on code designation, see the sections for code. Note 2: Level obtained when air was taken in under an environment equivalent to the measuring environment according to the specifications above. (See the descriptions on the cleanliness measuring environment below.) Note 3: Recommended speed for achieving Class 100. The value in parentheses is the maximum speed when cleanliness is not considered. When the stroke is 700 mm or over, the maximum speed is restricted. For details, see Pages 22 ~ 27. Note 4: A suction pump with required capacity to be provided by the user.

## Cleanness measurement points and particle counts

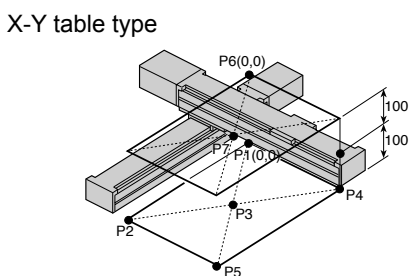
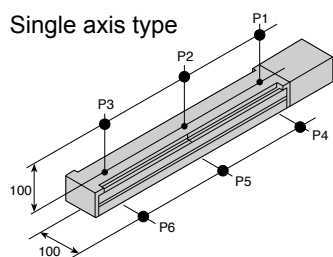

Unit: Q'ty (0.3 μm or larger)

Single axis type	Measurement point						X-Y table type	Measurement point						
	P1	P2	P3	P4	P5	P6		P1	P2	P3	P4	P5	P6	P7
BB10 (600st)	11	21	17	4	6	9	BB10×BB10 (400×400st)	23	19	13	6	17	4	2
BB30 (600st)	12	9	16	26	20	17	BB30×BB10 (400×400st)	30	30	16	19	22	5	21

### Cleanness measuring environment

Cleanness in measuring room : Class 10, in booth  
Downflow of measuring room : 0.1 ~ 0.3 m/sec  
Measuring instrument : Multiple-point particle counter  
(Minimum particle size measurable: 0.16 μm)  
Sample flowrate : 1 cubic feet/min.  
Stroke of measured axis : 600 mm  
Motion pattern : Continuous shuttle motion over full stroke,  
1-sec. pause at each end of stroke

### Measurement conditions

Axis speed : 400 mm/s  
Acceleration/deceleration time : 0.3 sec  
Air suction : 60 normal liters/min (BB10)  
150 normal liters/min (BB30)  
Others : Measuring environment, etc., as per the specifications.

## Speed and particle counts

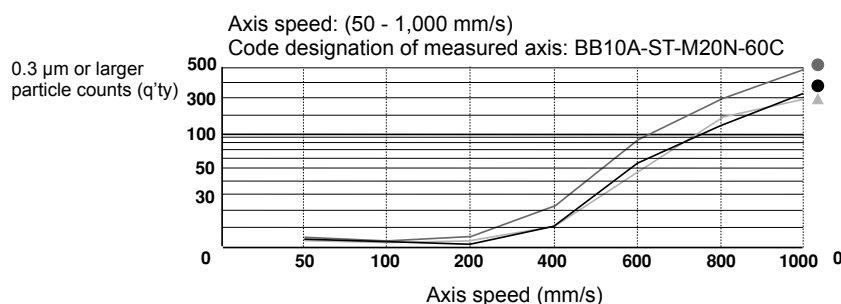

Measure at three points of the axis center.

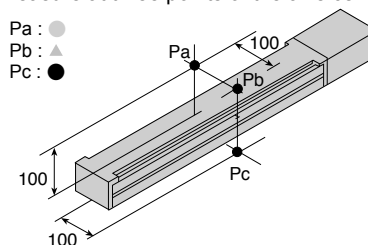



# Cleanroom axis BB10

[Code designation]

**BB10E - ST - M 20 N - 40 C**

<b>Motor spec.</b> E: Absolute 110W	<b>Axis structure</b> ST: Straight axis UR: Right side mounted motor axis UL: Left side mounted motor axis UU: Bottom side mounted motor axis	<b>Type of slider</b> M: Medium slider S: Short slider	<b>Lead</b> 20: 20mm 10: 10mm 05: 5mm	<b>Brake</b> N: Without brake	<b>Basic stroke</b> Medium slider Short slider 10: 100mm 15: 150mm 20: 200mm 25: 250mm A0: 1000mm A5: 1050mm	<b>Axis variation</b> C: Cleanroom axis
--	---	--	--	----------------------------------	--	--

• A combination bracket and CN box for the cleanroom axis are also available.

[Dimensions]

Code designation: BB10E-ST- □□□ N- □□ C  
Straight axis

Note 1: This value becomes 83 mm as a spacer is attached to the slider when the stroke is 700 mm or over.

**Medium slider**

**Short slider**

Code designation: BB10E-UL- □□□ N- □□ C  
Left side mounted motor axis

Note 1: This value becomes 83 mm as a spacer is attached to the slider when the stroke is 700 mm or over.  
Note 2: This value changes from 35 to 50 to extend the full length by 15 mm for the bottom side mounted motor axis (UU type).

**Medium slider**

**Short slider**

**T-slots**

Detail iA of T-slot    Detail iB of T-slot    Detail iC of T-slot    Detail iD of T-slot

# Cleanroom axis BB30

[Code designation]

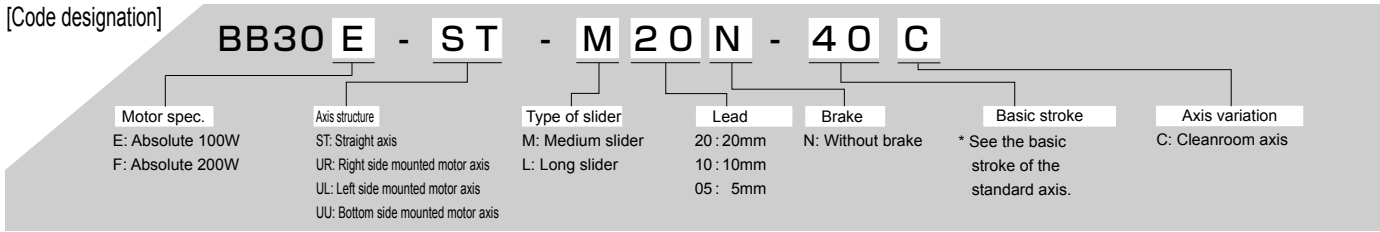

• A combination bracket and CN box for the cleanroom axis are also available.

[Dimensions]

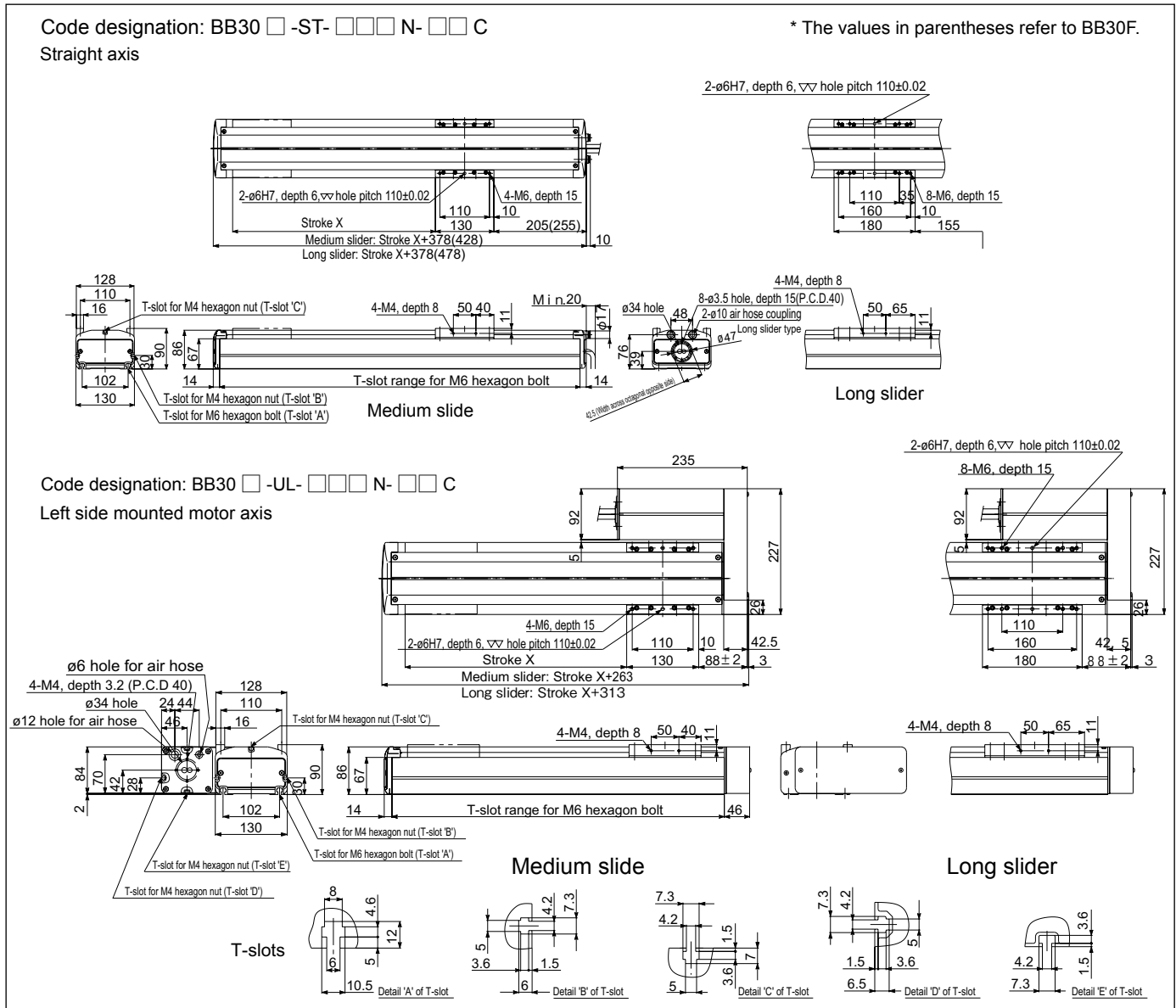

- Selection and installation of axes
  - \* Right side mounted motor axis, left side mounted motor axis and bottom side mounted motor axis are available as standard.
  - \* To keep the cleanliness level, use of reversed U-shaped wiring is recommended for cables between the axes. To run the wiring in this way, install CN boxes parallel to the X-axis center to avoid twisting cables.
  - \* For more information on this product, contact our sales office in your territory.
- Contact Toshiba Machine in the following cases.
  - \* When you wish to use the product under conditions not specified here, or in other than the cleanliness measuring environment.
  - \* When you wish to use an orthogonal (Cartesian) axes combination other than the X-Y table type.
  - \* When you wish to use an axis with brake.
  - \* When you wish to know the particle size for the particle counts described in this manual.
  - \* When you wish to procure a cleanroom axis other than the BA series shown in this manual.

# Axis-Related Components

## Components

Axis Combination Bracket .....	178
Controller Cable.....	186
CN Box .....	186
Flexible Tube .....	190
Flexible Duct.....	191
Tube Tray.....	192
Flexible Tray .....	192

## Options

Support Guide .....	193
Home Position Change Sensor .....	195
Strain Relief .....	195
Cable Grip .....	196

# Axis Combination Bracket

## [Application]

Brackets are used to combine axes (or actuators) in an orthogonal form. A large number of brackets are available to cope with various combinations. Bolts and nuts are attached.

## [Code designation]

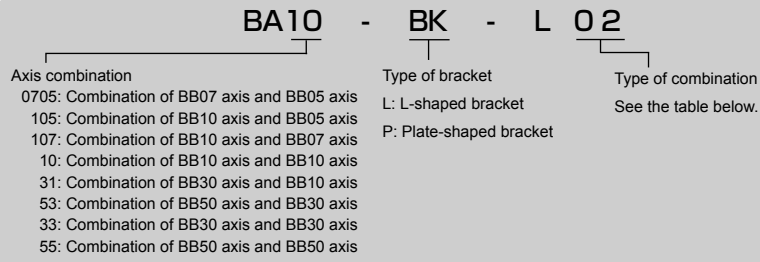

## [Type of brackets by axis combination]

Axis combination [1]	Basic axis	Axis 2	Type of bracket	Ref. Page
<p>X-Y Right-handed Y-axis slider opposite to motor side</p> <p>X-Y Left-handed Y-axis slider on motor side</p>	BB07	BB05	BA0705-BK-L02	P180
	BB10	BB07	BA107-BK-L02	P180
	BB10	BB05	BA105-BK-L02	P180
	BB10	BB10	BA10-BK-L02	P180
	BB30	BB10	BA31-BK-L02	P180
	BB50	BB30	BA53-BK-L02	P180
	BB30	BB30	BA33-BK-L02	P181
	BB50	BB50	BA55-BK-L02	P181

Axis combination [2]	Basic axis	Axis 2	Type of bracket	Ref. Page
<p>X-Y Left-handed Y-axis slider opposite to motor side</p> <p>X-Y Right-handed Y-axis slider on motor side</p>	BB07	BB05	BA0705-BK-L03	P181
	BB10	BB07	BA107-BK-L03	P181
	BB10	BB05	BA105-BK-L03	P181
	BB10	BB10	BA10-BK-L03	P181
	BB30	BB10	BA31-BK-L03	P182
	BB50	BB30	BA53-BK-L03	P182
	BB30	BB30	BA33-BK-L03	P182
	BB50	BB50	BA55-BK-L03	P182

Axis combination [3]	Basic axis	Axis 2	Type of bracket	Ref. Page
<p>X-Y table</p> <p>Y-Z</p> <p>Z-Y</p>	BB07	BB05	BA0705-BK-P06	P182
	BB10	BB07	BA107-BK-P06	P182
	BB10	BB05	BA105-BK-P06	P183
	BB10	BB10	BA10-BK-P06	P183
	BB30	BB10	BA31-BK-P06	P183
	BB50	BB30	BA53-BK-P06	P183

Axis combination [4]	Basic axis	Axis 2	Type of bracket	Ref. Page
<p>X-Y table X-Y move</p> <p>Y-Z move</p> <p>Z-Y move</p>	BB10	BB10	BA10-BK-P07	P183
	BB30	BB10	BA31-BK-P07	P183
	BB50	BB30	BA53-BK-P07	P184

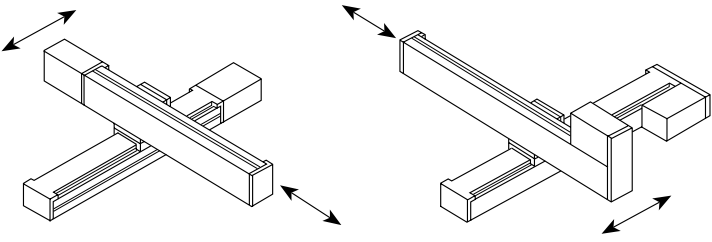
Axis combination [5]	Basic axis	Axis 2	Type of bracket	Ref. Page
 <p>X-Y move Right-handed</p> <p>X-Y move Left-handed</p>	BB10	BB10	BA10-BK-L04	P184

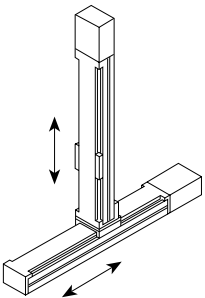
Axis combination [6]	Basic axis	Axis 2	Type of bracket	Ref. Page
	BB10	BB10	BA11-BK-L01	P184
	BB30	BB10	BA31-BK-L01	P184
	BB50	BB30	BA53-BK-L01	P184
	BB30	BB30	BA33-BK-L01	P184
	BB50	BB50	BA55-BK-L01	P185

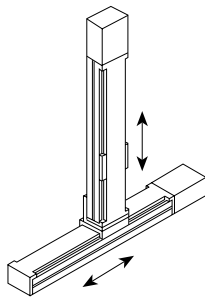
Axis combination [7]	Basic axis	Axis 2	Type of bracket	Ref. Page
 <p>X-Z Z-axis facing sideways</p>	BB10	BB10	BA10-BK-L05	P185

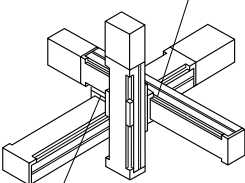
Axis combination [8]				
 <p>See Axis combination [3] Y-Z.</p> <p>See Axis combination [1] X-Y.</p> <p>X-Y-Z Right-handed Y-axis slider opposite to motor side</p>				

# Dimensions of Axis Combination Bracket

[BA0705-BK-L02] Material: Aluminum alloy, mass 0.5 kg

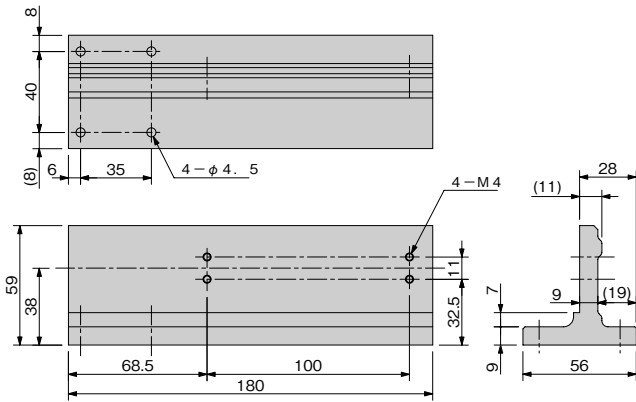

[BA107-BK-L02] Material: Aluminum alloy, mass 0.8 kg

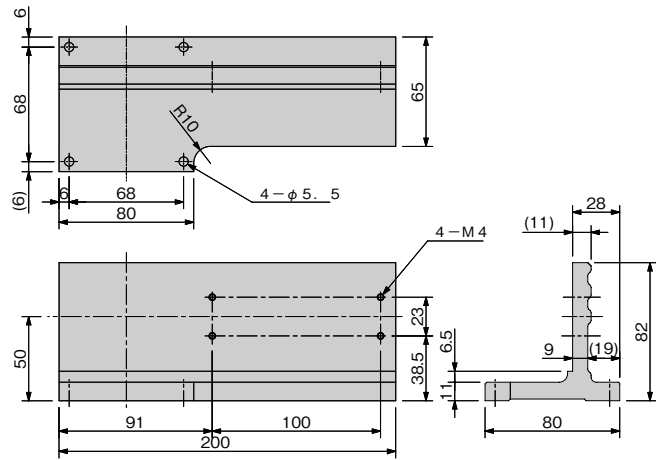

[BA105-BK-L02] Material: Aluminum alloy, mass 0.8 kg

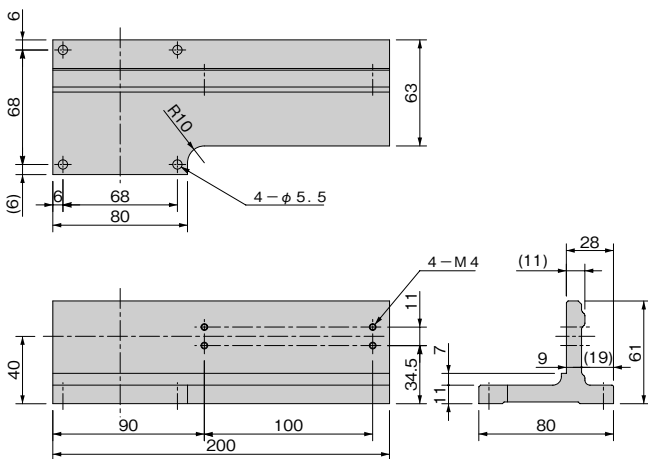

[BA10-BK-L02] Material: Aluminum alloy, mass 0.9 kg

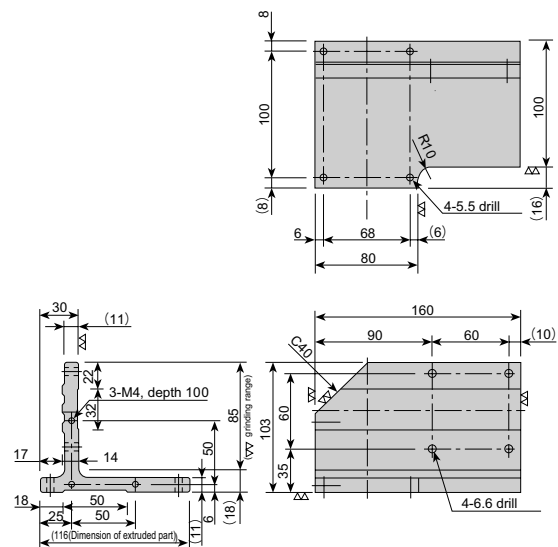

[BA31-BK-L02] Material: Aluminum alloy, mass 1.9 kg

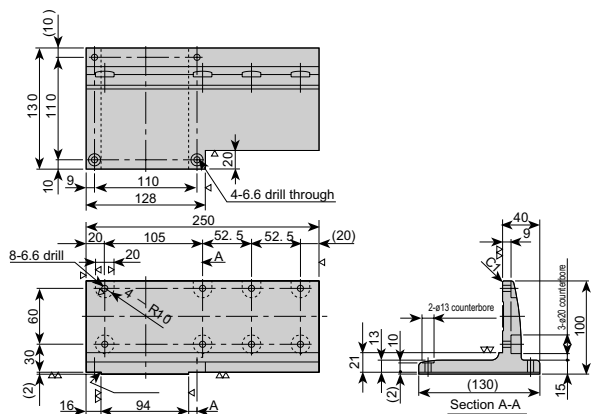

[BA53-BK-L02] Material: Aluminum alloy, mass 8.5 kg

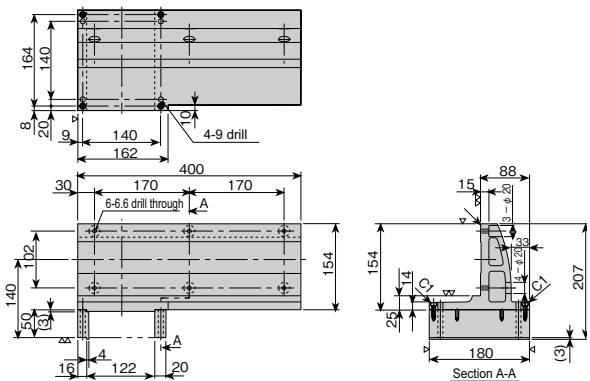

# Dimensions of Axis Combination Bracket

[BA33-BK-L02] Material: Aluminum alloy, mass 5.9 kg

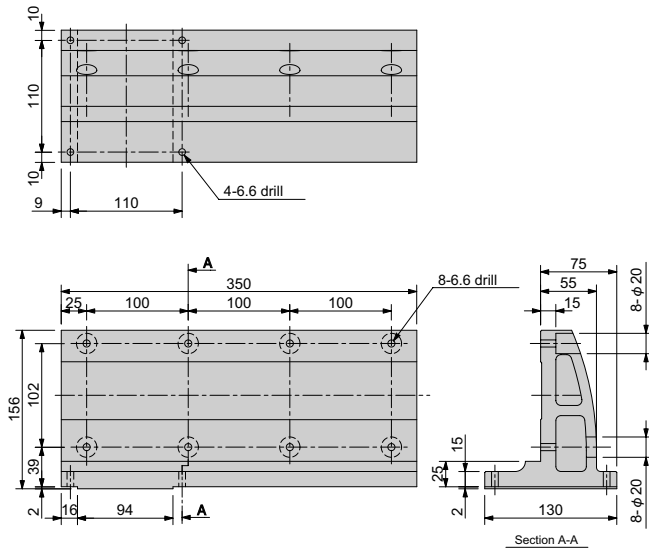

[BA55-BK-L02] Material: Aluminum alloy, mass 10 kg

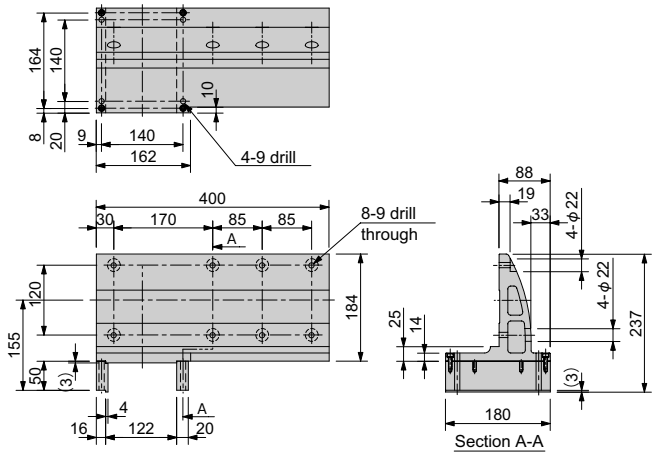

[BA0705-BK-L03] Material: Aluminum alloy, mass 0.5 kg

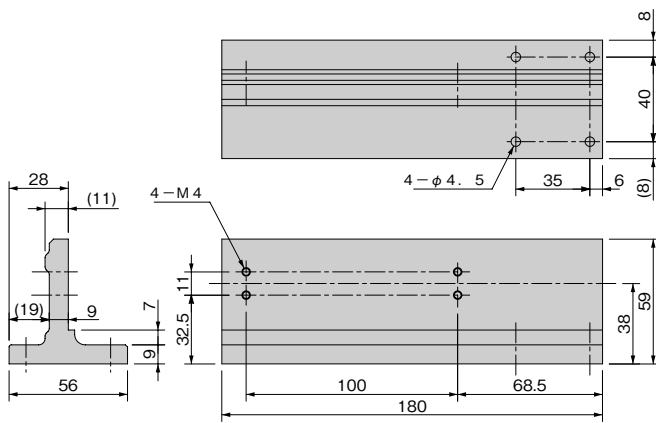

[BA107-BK-L03] Material: Aluminum alloy, mass 0.8 kg

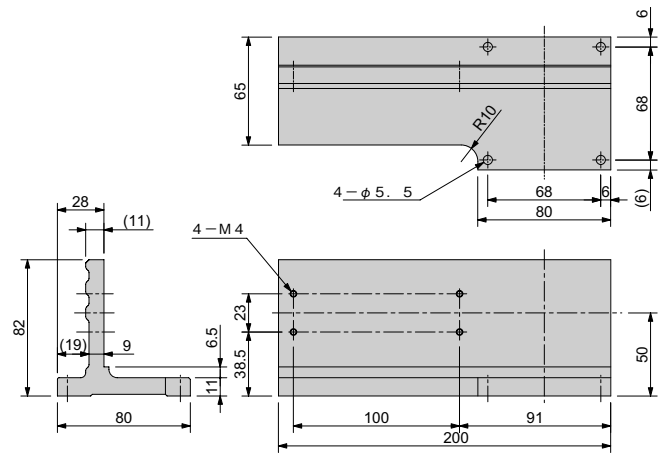

[BA105-BK-L03] Material: Aluminum alloy, mass 0.8 kg

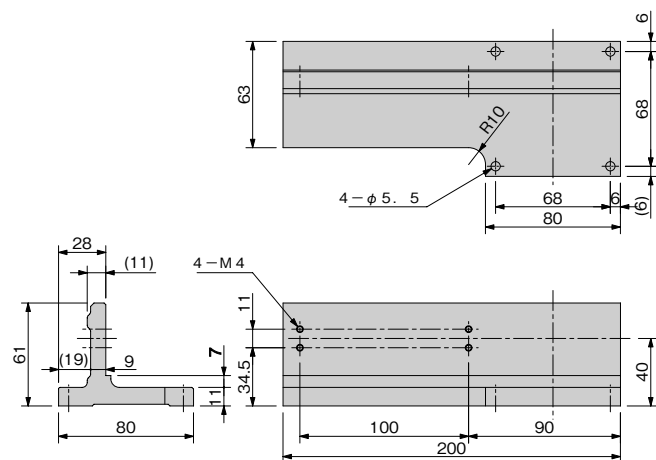

[BA10-BK-L03] Material: Aluminum alloy, mass 0.9 kg

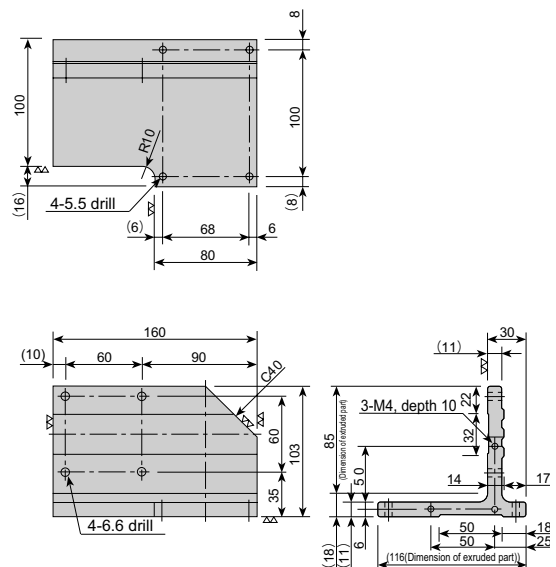

# Dimensions of Axis Combination Bracket

[BA31-BK-L03] Material: Aluminum alloy, mass 1.9 kg

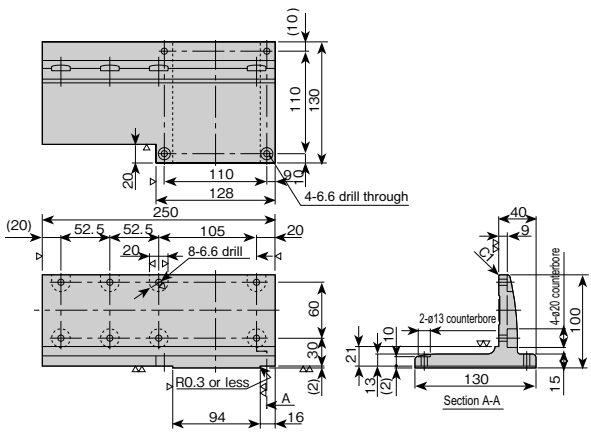

[BA53-BK-L03] Material: Aluminum alloy, mass 8.5 kg

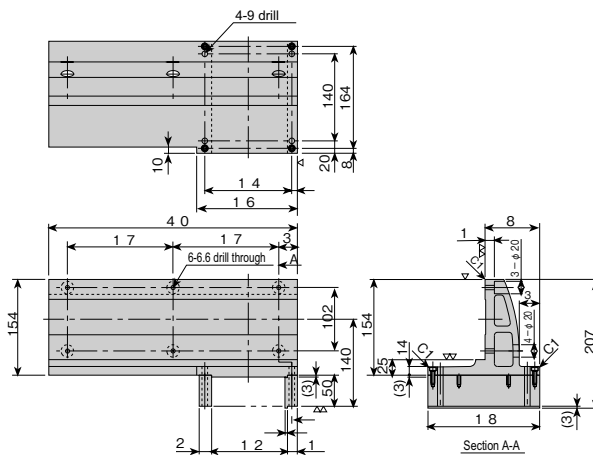

[BA33-BK-L03] Material: Aluminum alloy, mass 5.9 kg

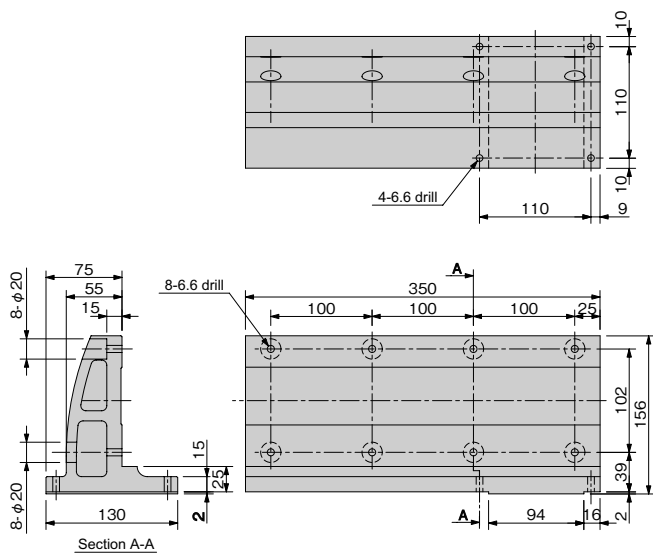

[BA55-BK-L03] Material: Aluminum alloy, mass 10 kg

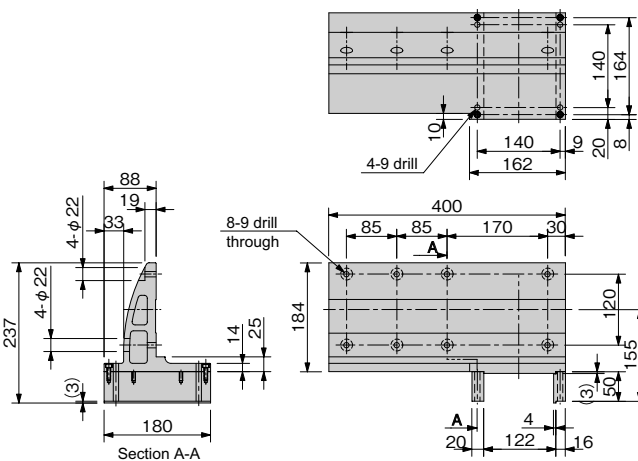

[BA0705-BK-P06] Material: Aluminum alloy, mass 0.3 kg

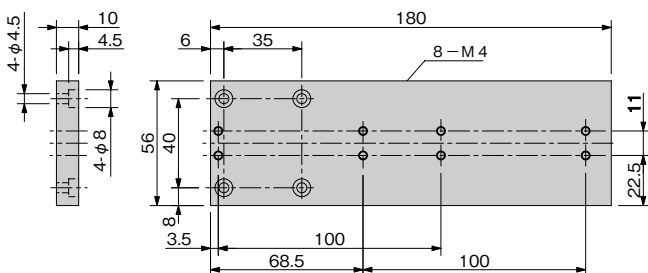

[BA107-BK-P06] Material: Aluminum alloy, mass 0.5 kg

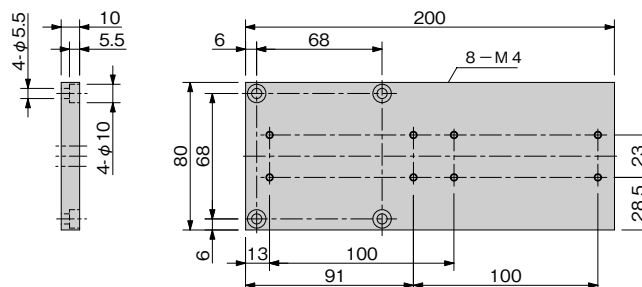



# Dimensions of Axis Combination Bracket

<p>[BA105-BK-P06] Material: Aluminum alloy, mass 0.5 kg</p> <p>Technical drawing of bracket BA105-BK-P06. Front view shows a rectangular plate with a total width of 200 mm and a total height of 80 mm. It features 8 M4 mounting holes arranged in two vertical columns of four. The top edge has a chamfered section with a 4-φ5.5 hole. Dimensions include 68 mm between hole centers, 6 mm from the top edge to the first hole, and 34.5 mm from the bottom edge to the first hole. A side view shows a thickness of 11 mm. A top view shows a 90 mm by 100 mm footprint with 20 mm and 100 mm dimensions.</p>	<p>[BA10-BK-P06] Material: Aluminum alloy, mass 0.6 kg</p> <p>Technical drawing of bracket BA10-BK-P06. Front view shows a rectangular plate with a total width of 130 mm and a total height of 116 mm. It features 4-φ16 mounting holes in two columns of two. Dimensions include 49 mm, 50 mm, and 7 mm from the top edge to the first hole, and 116 mm between hole centers. A side view shows a thickness of 11 mm. A top view shows a 110 mm by 130 mm footprint with 31 mm and 68 mm dimensions. It includes 4-6.6 drill through and 4-5.5 drill through holes, and 4-M4 depth 8 holes.</p>
<p>[BA31-BK-P06] Material: Aluminum alloy, mass 0.9 kg</p> <p>Technical drawing of bracket BA31-BK-P06. Front view shows a rectangular plate with a total width of 180 mm and a total height of 110 mm. It features 4-φ6.6 and 4-φ16 mounting holes. Dimensions include 42 mm, 10 mm, and 7 mm from the top edge to the first hole, and 180 mm between hole centers. A side view shows a thickness of 5 mm. A top view shows a 160 mm by 110 mm footprint with 35 mm and 110 mm dimensions. It includes 4-φ11 and 4-φ6.6 holes.</p>	<p>[BA53-BK-P06] Material: Aluminum alloy, mass 1.5 kg</p> <p>Technical drawing of bracket BA53-BK-P06. Front view shows a rectangular plate with a total width of 210 mm and a total height of 180 mm. It features 4-φ9 and 4-φ16 mounting holes. Dimensions include 42 mm, 10 mm, and 11 mm from the top edge to the first hole, and 210 mm between hole centers. A side view shows a thickness of 5 mm. A top view shows a 190 mm by 140 mm footprint with 35 mm and 140 mm dimensions. It includes 4-φ6.6 and 4-φ14 holes.</p>
<p>[BA10-BK-P07] Material: Aluminum alloy, mass 0.5 kg</p> <p>Technical drawing of bracket BA10-BK-P07. Front view shows a rectangular plate with a total width of 116 mm and a total height of 100 mm. It features 4-φ10 mounting holes in two columns of two. Dimensions include 15 mm, 8 mm, and 8 mm from the top edge to the first hole, and 116 mm between hole centers. A side view shows a thickness of 10 mm. A top view shows a 100 mm by 116 mm footprint with 24 mm and 68 mm dimensions. It includes 4-5.5 drill through holes.</p>	<p>[BA31-BK-P07] Material: Aluminum alloy, mass 0.7 kg</p> <p>Technical drawing of bracket BA31-BK-P07. Front view shows a rectangular plate with a total width of 128 mm and a total height of 130 mm. It features 4-φ5.5 and 4-φ7 mounting holes. Dimensions include 16 mm, 10 mm, 9 mm, and 14 mm from the top edge to the first hole, and 128 mm between hole centers. A side view shows a thickness of 10 mm. A top view shows a 110 mm by 130 mm footprint with 31 mm and 68 mm dimensions. It includes 4-φ5.5 and 4-φ7 holes.</p>

# Dimensions of Axis Combination Bracket

[BA53-BK-P07] Material: Aluminum alloy, mass 1.3 kg

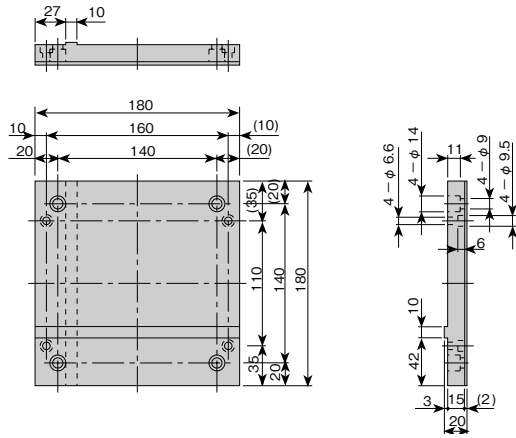

[BA10-BK-L04] Material: Aluminum alloy, mass 0.7 kg

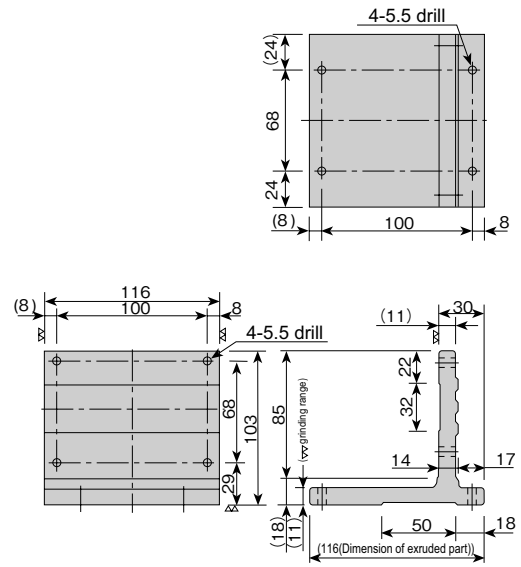

[BA11-BK-L01] Material: Aluminum alloy, mass 1.8 kg

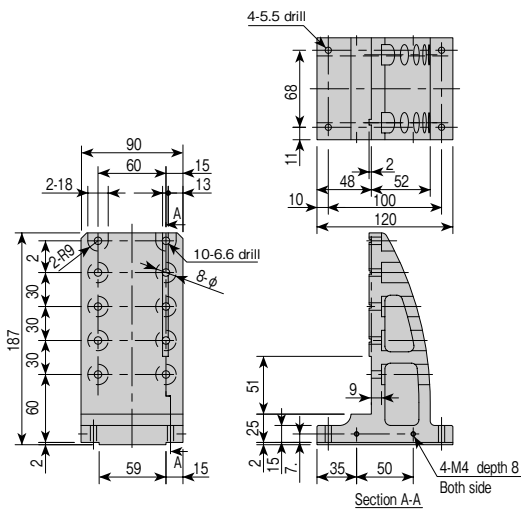

[BA31-BK-L01] Material: Aluminum alloy, mass 2.1 kg

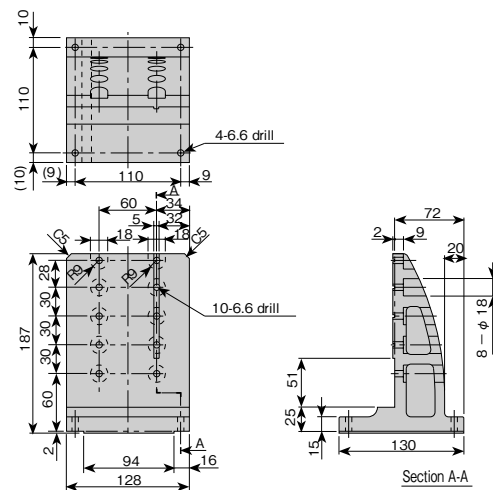

[BA53-BK-L01] Material: Aluminum alloy, mass 4.5 kg

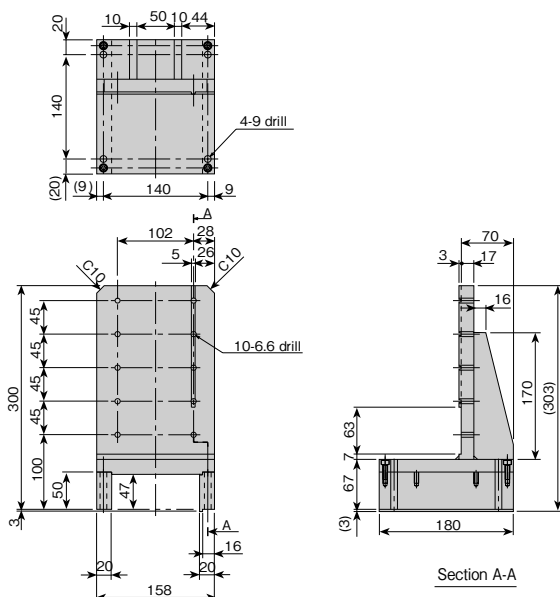

[BA33-BK-L01] Material: Aluminum alloy, mass 2.1 kg

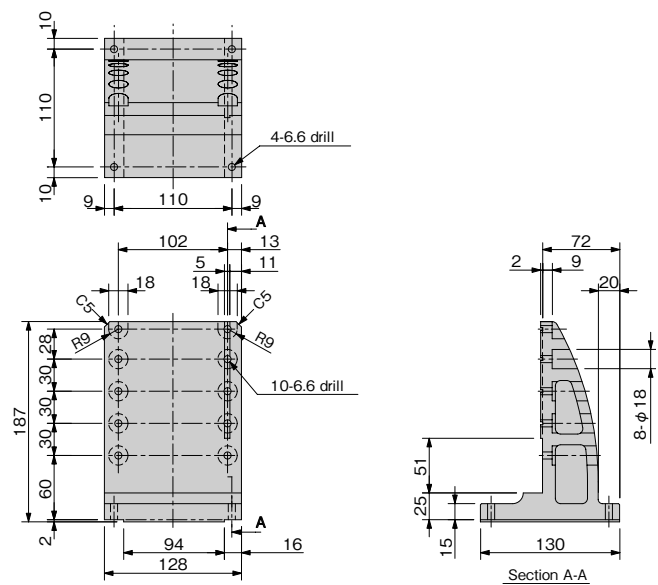

# Dimensions of Axis Combination Bracket

[BA55-BK-L01] Material: Aluminum alloy, mass 5.0 kg

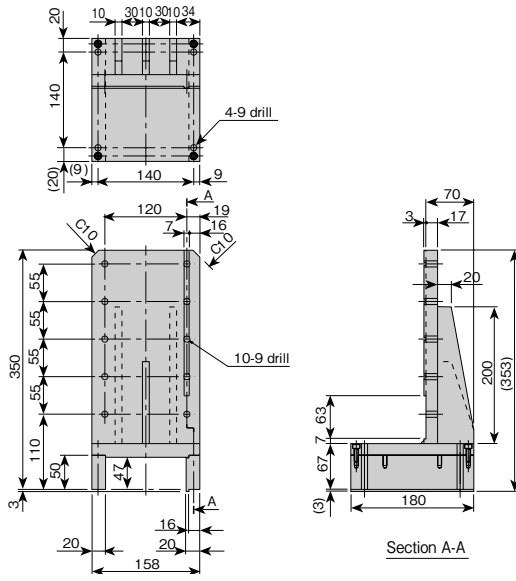

[BA10-BK-L05] Material: Aluminum alloy, mass 0.7 kg

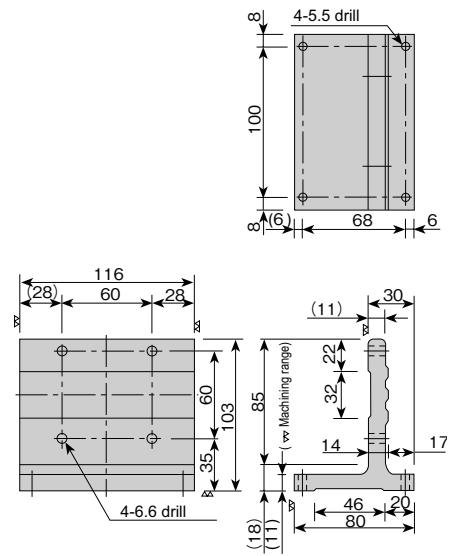

# Controller Cable

## [Application]

Used to connect a controller with an actuator (or axis). The controller cable consists of motor and encoder signal cables (i.e., two flexible cables). When used for an orthogonal (or Cartesian) two axes system, the cable for the axis 2 should be 2 m longer than that of the axis 1 generally. This cable is exclusively used for the actuator, and no user's cable is included.

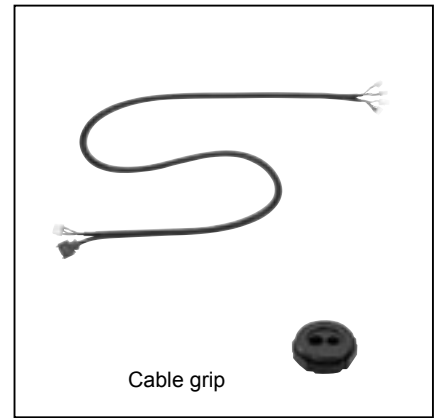

## [Code designation]

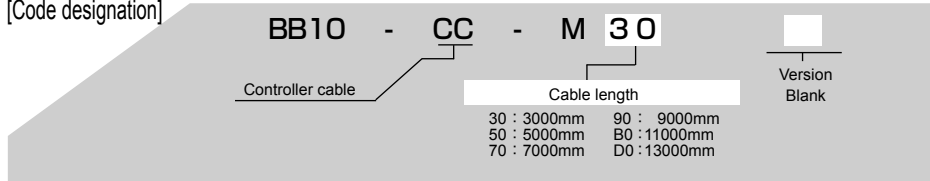

- \* The controller cable is supplied as a pair of one each of motor cable and encoder signal cable. A cable grip for these two cables is attached.
- \* When using the controller cable for the orthogonal two axes system, pass the cable for the axis 2 through a flexible tube or flexible duct (which is available for an extra price).
- \* For the cable length of any special axis combination, consult with us each time.

## [Dimensions]

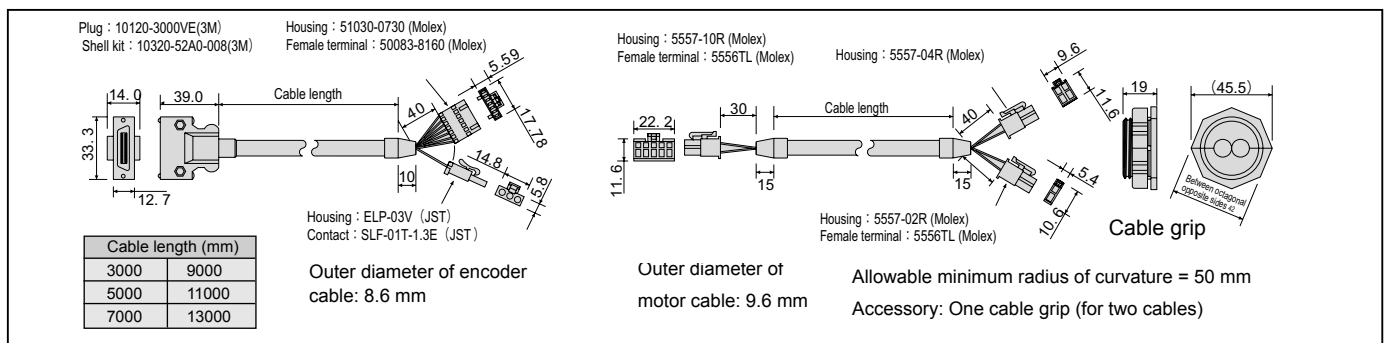

# CN Box

## [Application]

Used to secure the both ends of a flexible tube or flexible duct. A CN box is mounted by using a T-slot on the side of the actuator, on top of the frame cover or on the motor cover. The CN box can also be mounted on user's equipment. For a single axis system, this box may not be required.



## [Code designation]

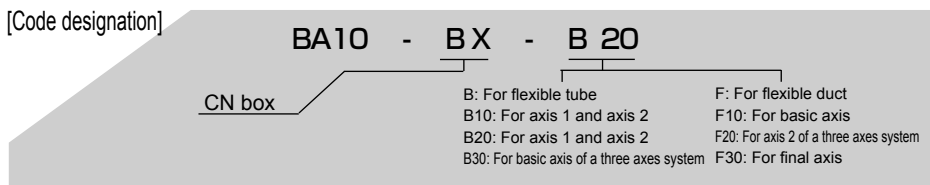

- \* A CN box is supplied with a set of caps, metal fixtures, grommets, cable securing fixtures.
- \* A controller cable only passes through the box and is connected by means of connectors.
- \* Order CN box in quantity of 1 piece and up.

## [Dimensions]

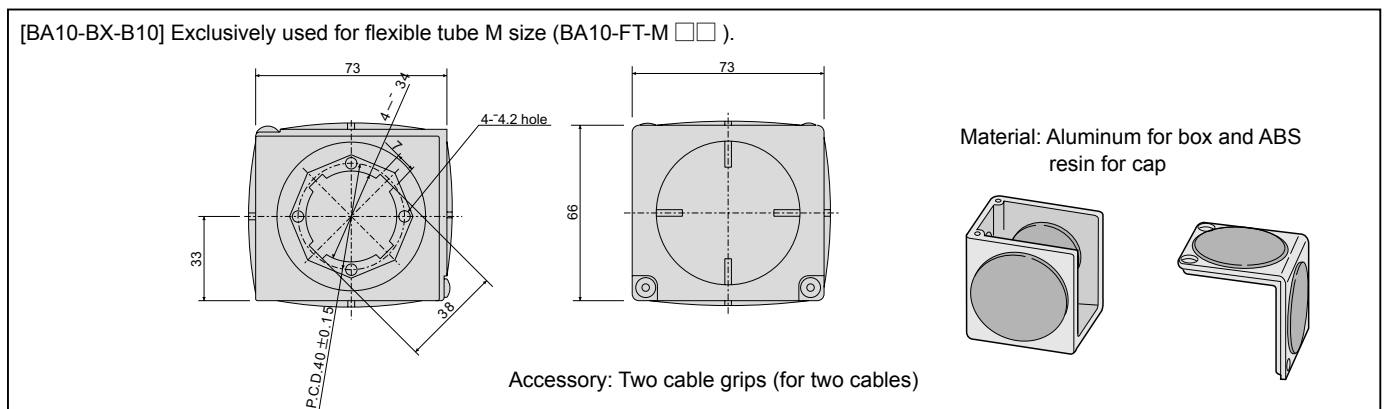

[BA10-BX-B20] Exclusively used for flexible tube L size (BA10-FT-L □□ ).

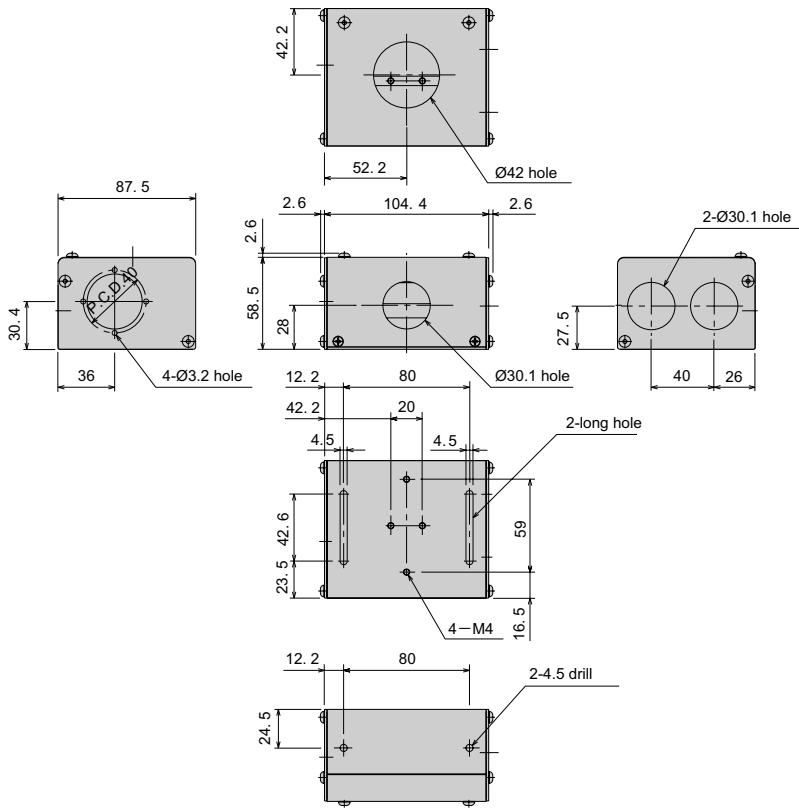

No.	Accessory	Qty	
1		1	
2		1	
3		1 set	
4		3	
5		3	
6	Cross-recessed pan head screw	M4 × 8	2
7	Hexagon nut	M4	2

[BA10-BX-B30] Exclusively used for flexible tube L size (BA10-FT-L □□ ).

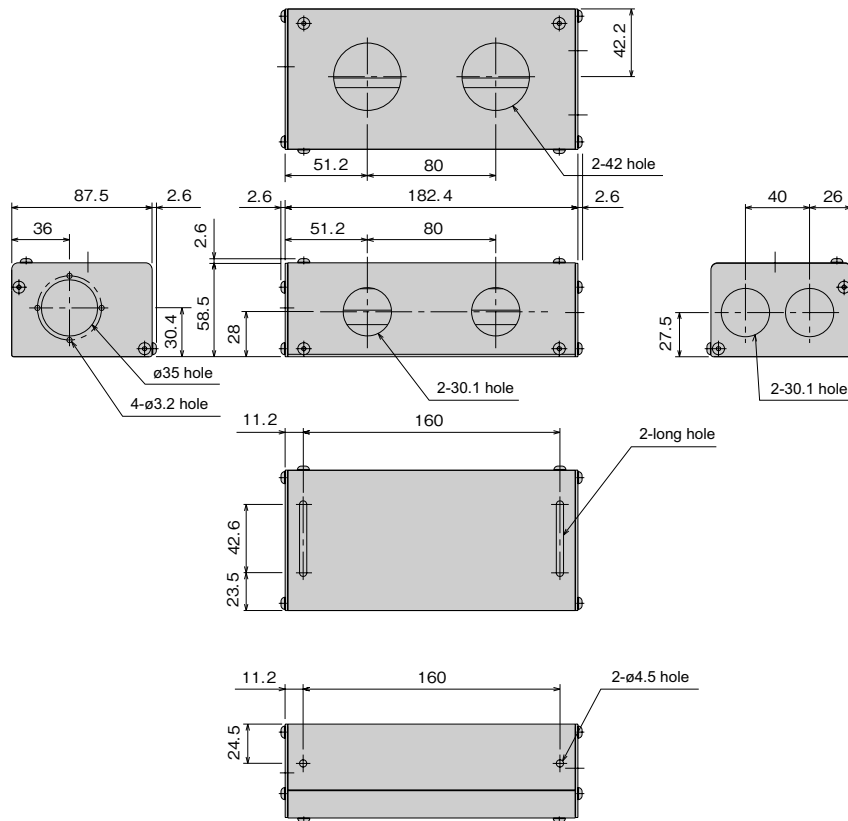

No.	Accessory	Qty	
1		1	
2		1	
3		1 set	
4		4	
5		4	
6	Cross-recessed pan head screw	M4 × 8	2
7	Hexagon nut	M4	2

[Dimensions]

[BA10-BX-F10] Exclusively used for flexible duct (BA10-FD-□□□).

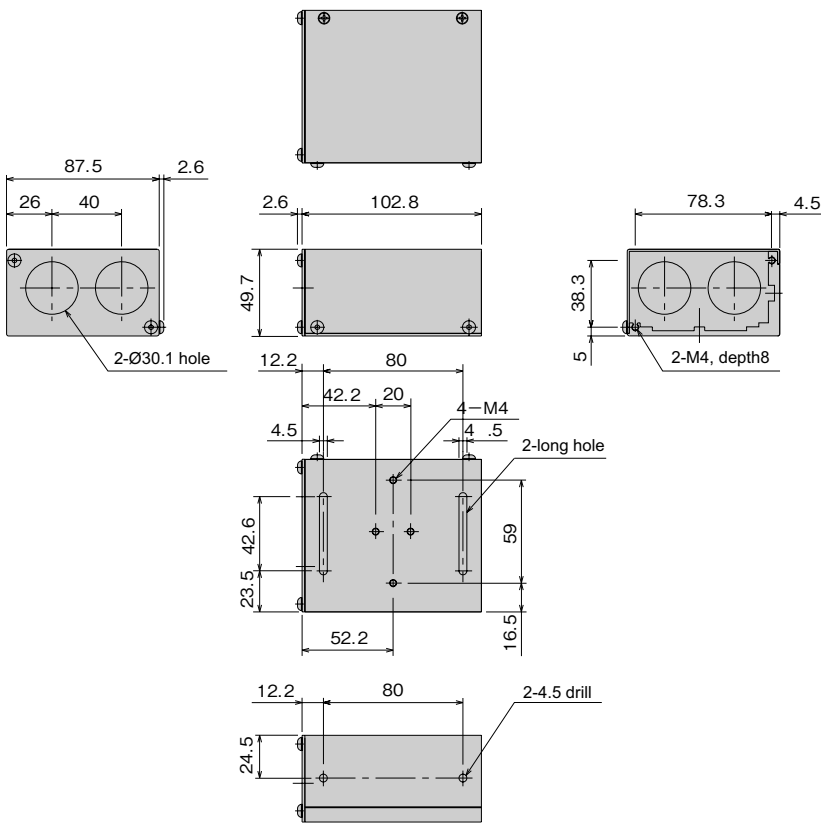

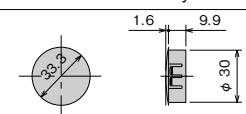
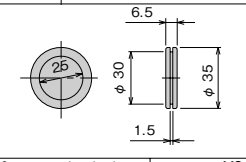
No.	Accessory	Qty	
1		1	
2		2	
3	Cross-recessed pan head screw	M8×8	2
4	Hexagon nut	M4	2

[BA10-BX-F20] Exclusively used for flexible duct (BA10-FD-□□□).

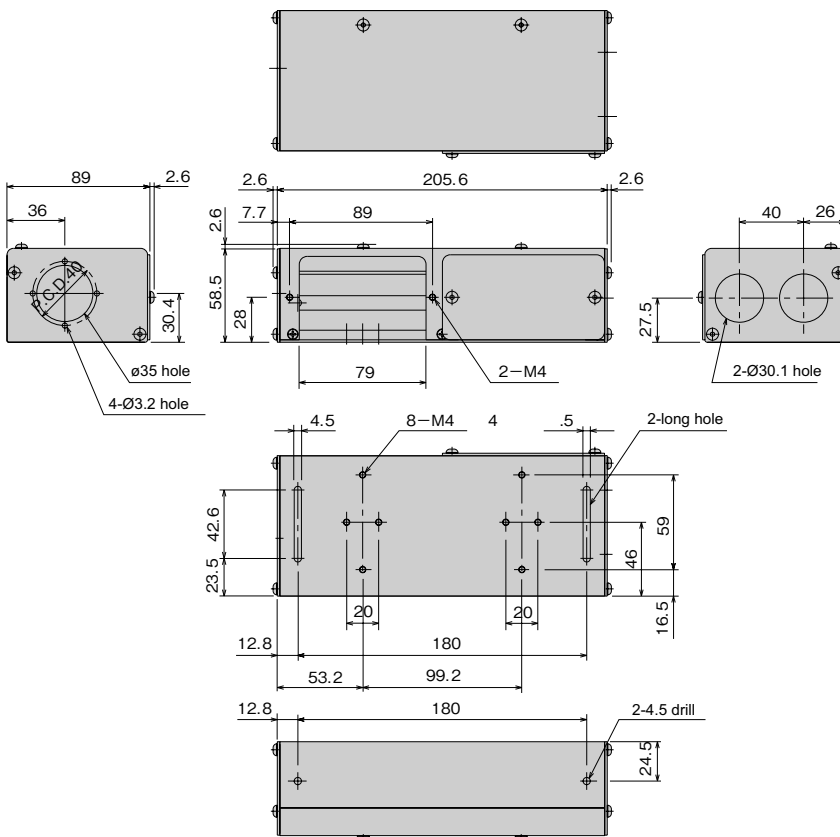

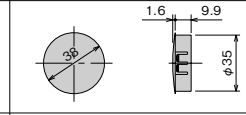
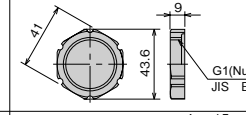
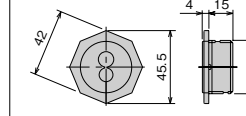
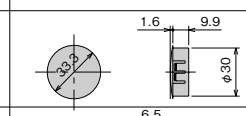
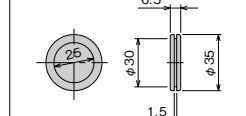
No.	Accessory	Qty	
1		1	
2		1	
3		1 set	
4		2	
5		2	
6	Cross-recessed pan head screw	M4×8	2
7	Hexagon nut	M4	2

[BA10-BX-F30] Exclusively used for flexible duct (BA10-FD-□□□□).

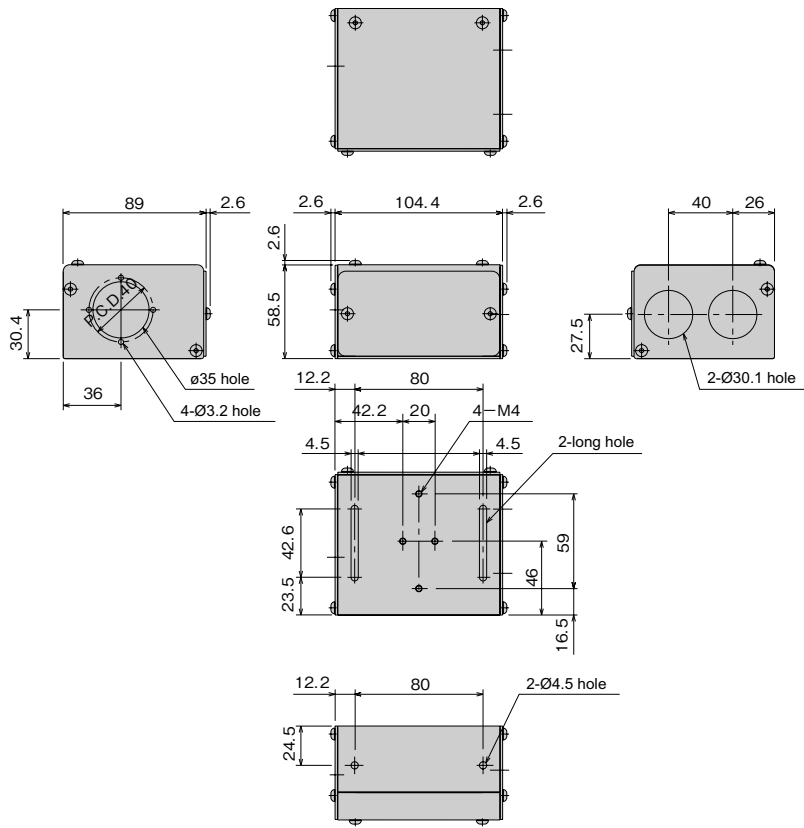

No.	Accessory	Qty	
1		1	
2		1	
3		1 set	
4		2	
5		2	
6	Cross-recessed pan head screw	M4×8	2
7	Hexagon nut	M4	2

## CN Box Wrench

[Code designation]

CGSP - 41

[Application]

This is a special wrench used for clamping the resin nut of cable grip to the CN box and actuator.

[Dimensions]

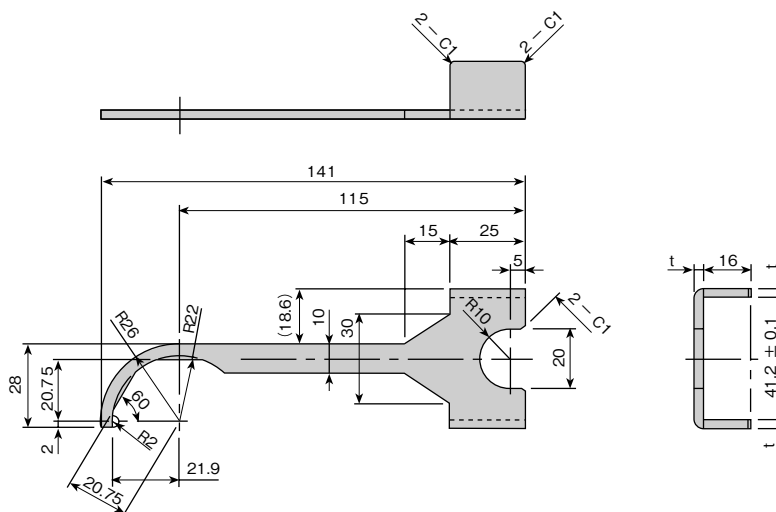

# Flexible Tube

## [Application]

Used to protect a controller cable which connects orthogonal two axes. It is also possible to pass a signal cable for tooling or other air tubing through this flexible tube. This flexible tube can be arranged vertically (cable track style) or horizontally (hoop cable style; only M size). To use this tube, an exclusive CN box (available for an extra price) is necessary.

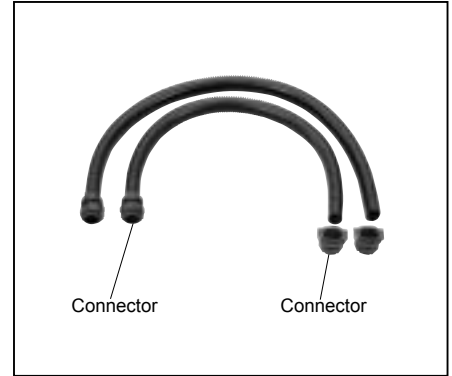

## [Code designation]

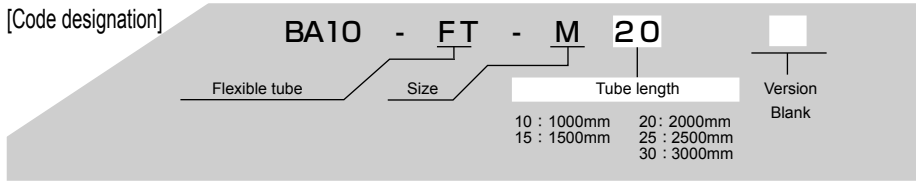

- \* Two special connectors, and clamps and bands for securing each cable at the tube inlet are attached.
- \* The tube section is oval and cannot be twisted between the tube and connector.
- \* The flexible tube can be severed easily by using a cutter knife. When connecting the tube, allow enough radius of curvature.
- \* As a yardstick, length of flexible tube which connects orthogonal two axes is three times the stroke of the axis 1.
- \* Select the flexible tube which connects with the axis 2 slider (or axis end of traveling axis), according to the form of installation.

## [Dimensions]

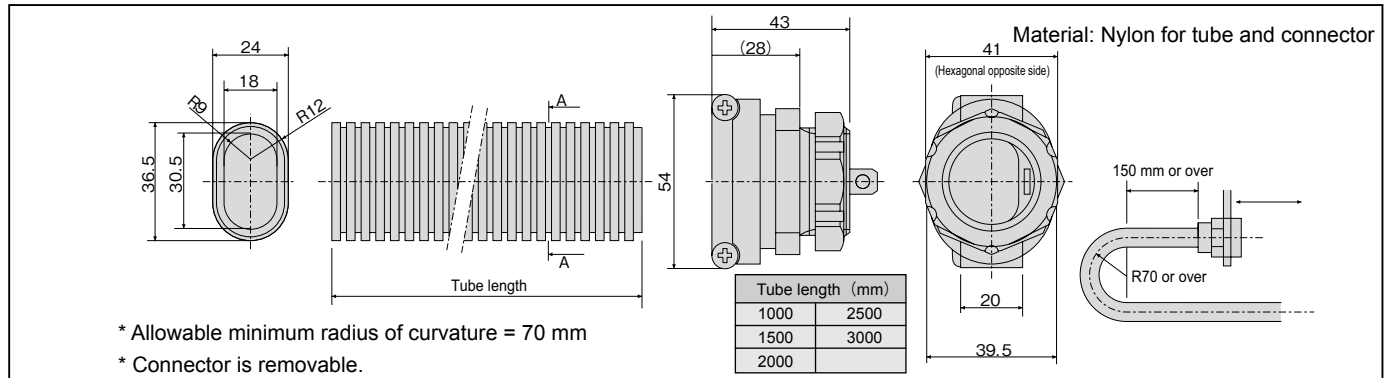

## [Code designation]

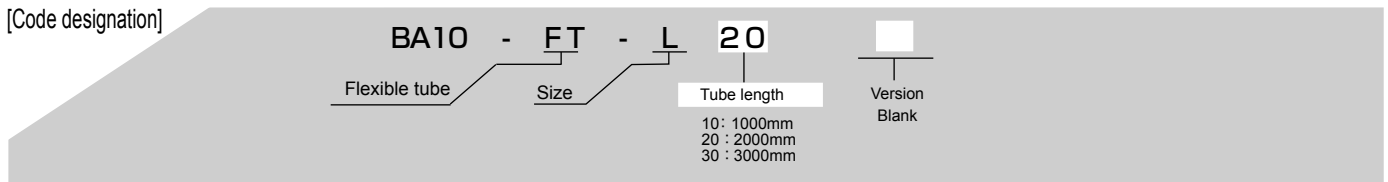

- \* Two special connectors are attached.
- \* The flexible tube can be severed easily by using a cutter knife. When connecting the tube, allow enough radius of curvature.
- \* As a yardstick, length of flexible tube which connects orthogonal two axes is three times the stroke of the axis 1.

## [Dimensions]

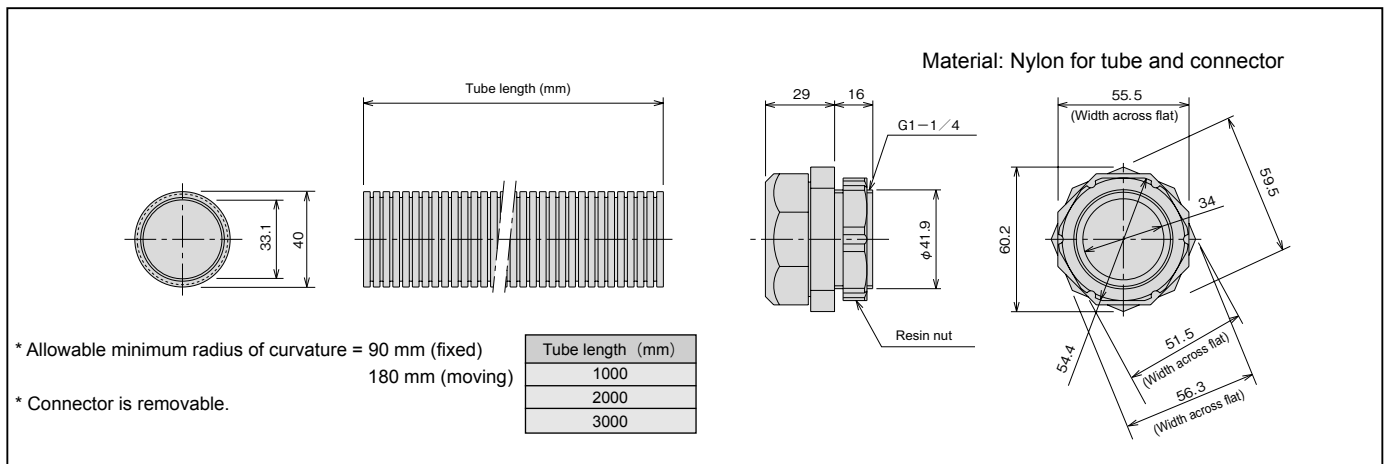



# Flexible Duct

## [Application]

Used to protect a controller cable which connects with the moving part. It is also possible to pass a signal cable for tooling or air tubing through this flexible duct. To use this duct, an exclusive CN box (available for an extra price) is necessary.

## [Code designation]

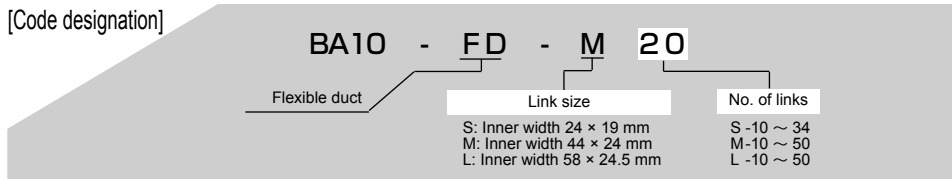

- \* Select the flexible duct which has enough clearance for cables and tubes to pass through.
- \* Select the number of links with good margin, referring to the duct selection stated below.

## [Duct selection for connecting axis 1 and axis 2]

- [1] Select the link size.
- [2] Figure out the full length (L) of the duct.
- [3] Figure out the number of links required (A).

Full length of duct (L) = Basic length (B) + X-axis stroke (X)  
No. of links (A) = Full length of duct ÷ Link pitch (C)  
Note: Fraction of the number of links is to be rounded up.

Combination	Axis 1	Axis 2	Link size	Basic length mm (B)
X - Y	BB30-ST	BB10-ST	M (L is applicable.)	585
	BB30-UR/UL	BB10-UR/UL	M (L is applicable.)	360
	BB50-ST	BB30-ST	L (M is applicable.)	630
	BB50-UR/UL	BB30-ST	L (M is applicable.)	540
X - Z	BB30-ST	BB10-ST	M (L is applicable.)	630
	BB30-UR/UL	BB10-UR/UL	M (L is applicable.)	360
	BB50-ST	BB30-ST	L (M is applicable.)	765
	BB50-UR/UL	BB30-UR/UL	L (M is applicable.)	675

Link size	Pitch mm (C)
S	32
M	45
L	45

\* Shown above are representative examples. For other combinations, contact us.

## [Dimensions]

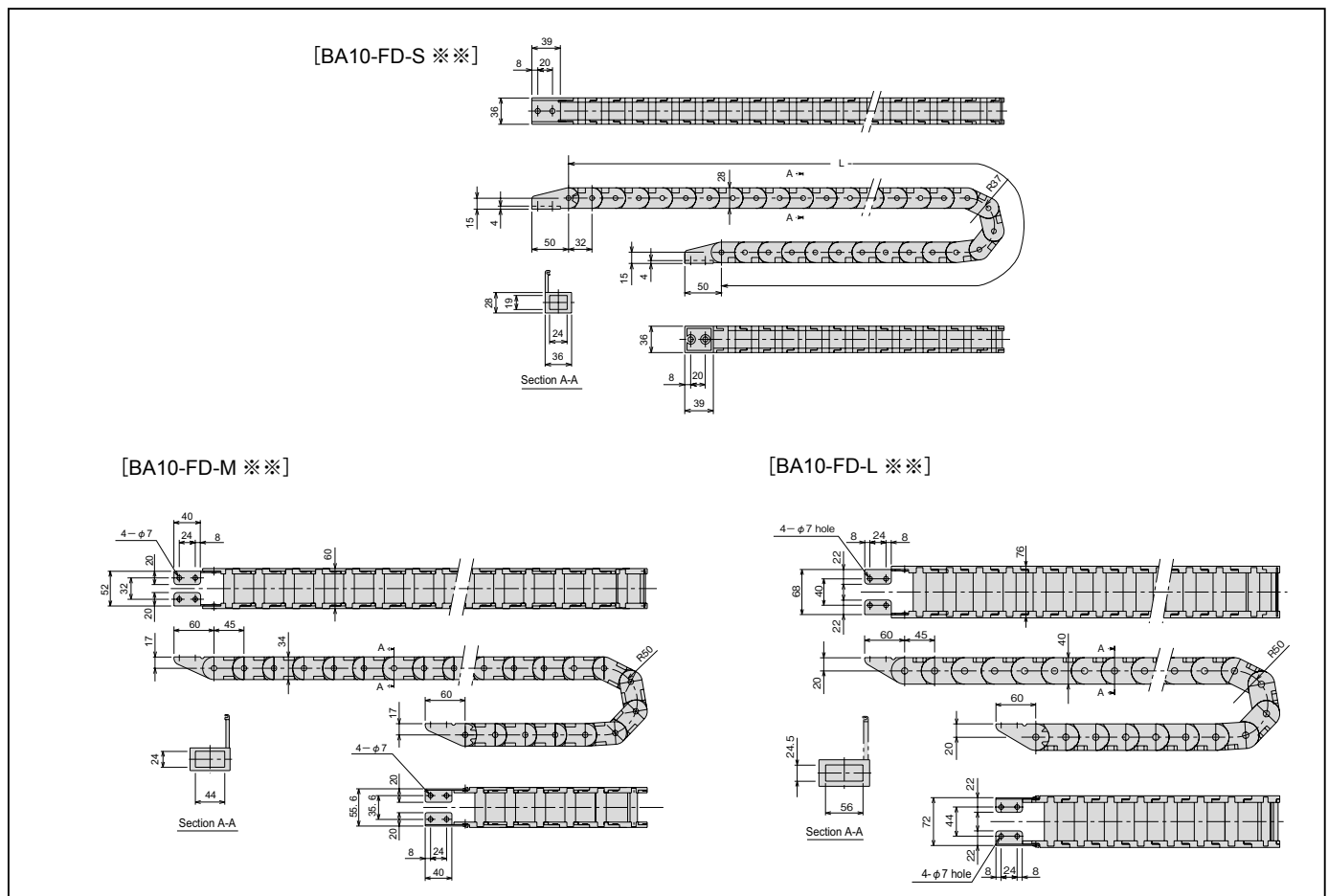

# Tube Tray

## [Application]

Used to hold a flexible tube when the tube is placed horizontally.  
This tray is secured to the 4 mm-wide T-slot on the side of the actuator.  
It not only supports a flexible tube, but prevents lateral movement of the tube.

## [Code designation]

**BA10 - TT - M 23**

Tube tray      Tray length      Version Blank

23 : 230mm	A3 : 1030mm
43 : 430mm	C3 : 1230mm
63 : 630mm	
83 : 830mm	

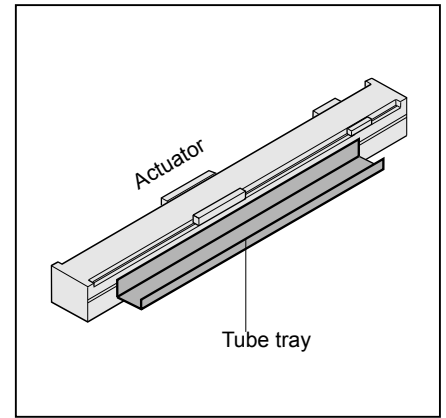

## [Dimensions]

**Material: Stainless steel**

L (mm)	B	C
230	1	2
430	3	4
630	5	6
830	7	8
1030	9	10
1230	11	12

Accessories: L-shaped metal fittings and set screws

Components

# Flexible Tray

## [Application]

Used to hold a flexible duct.  
This tray is secured to the 4 mm-wide T-slot on the side of the actuator.  
It prevents lateral movement of the duct.

## [Code designation]

**BA10 - TT - L 24**

Flexible tray      Tray length

24 : 240mm	84 : 840mm
44 : 440mm	A4 : 1040mm
64 : 640mm	

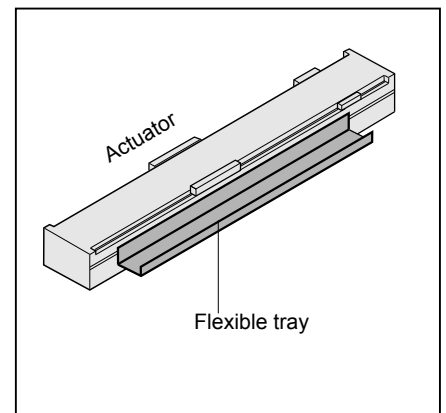

## [Dimensions]

**Material: Stainless steel**

L (mm)	A	B
240	2	1
440	3	2
640	4	3
840	5	4
1040	6	5

Accessories: Hex socket button-head screws and hexagon nuts

# Support Guide

## [Application]

This is a guide rail which is used to support the Y-axis end.  
 When the support guide is mounted on the end of the Y-axis, moment imposed on the X-axis can be reduced with less deflection of the Y-axis.  
 It is useful for the work requiring rigidity or long Y-axis stroke.

## [Code designation]

**BA 10 – SG – M 40**

Axis combination	X-axis stroke
10: BB10 (X-axis) - BB10 (Y-axis)	10 : 100mm JO : 1800mm
31: BB30 (X-axis) - BB10 (Y-axis)	90 : 900mm NO : 2200mm
53: BB50 (X-axis) - BB50 (Y-axis)	A0 : 1000mm PO : 2300mm
	H0 : 1700mm RO : 2500mm

## ■ Deflection ■

As shown in the right figure, deflection is measured by exerting 5 kg load on the slider with the Y-axis slider located on the end.

(Example) X-axis : BB10E-ST-M, Y-axis : BB10E-ST-S (450mm stroke)

	Deflection
Without support guide	0.4mm
With support guide	0.07mm

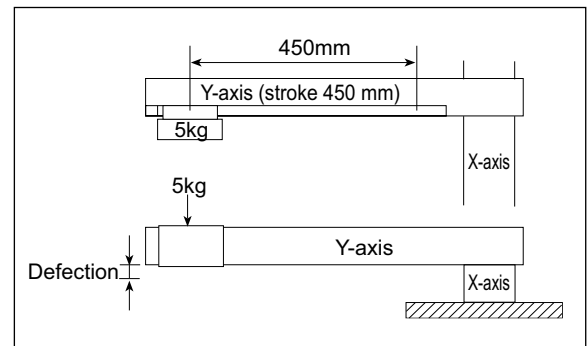
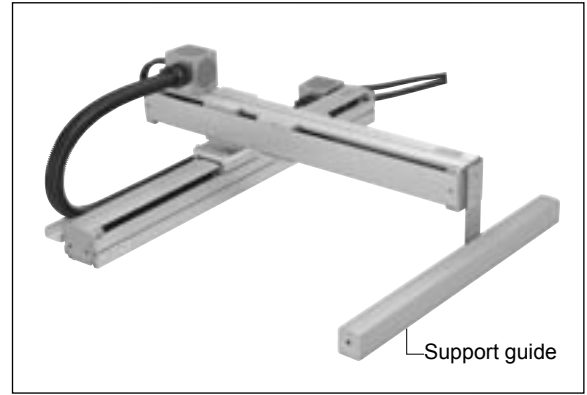

## [Payload]

As moment exerted on the X-axis can be reduced, payload for axis combination can be increased, which differs with the type of combination. For details, contact our sales office in your territory.

## [Outer dimensions]

### BA10-SG

X-axis: BB10 □ - □□ -M □□ N- □□

Y-axis: BB10 □ - □□ -M □□ N- □□

Common to both ball screw drive type and timing belt drive type.

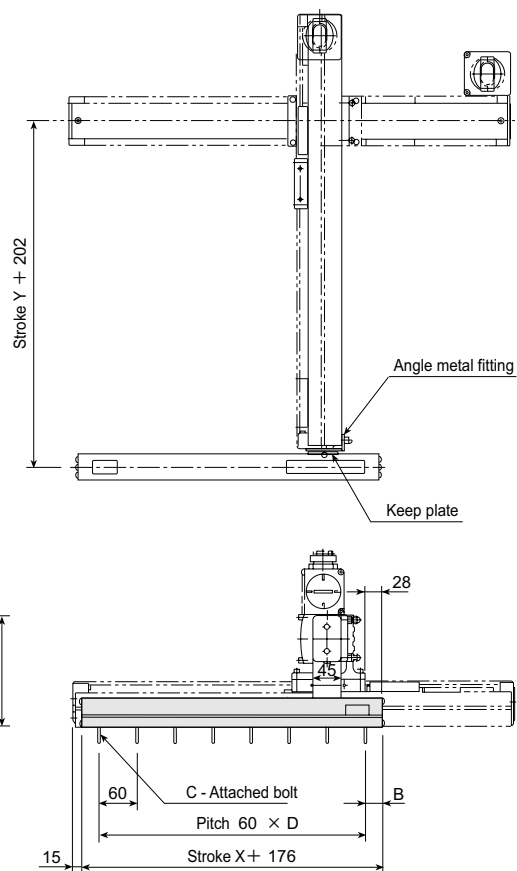

Stroke X (mm)	100	200	300	400	500	600	700	800	900	1000	1100	1200	1300	1400	1500
B (mm)	17.6	7.6	27.6	17.6	7.6	27.6	17.6	7.6	27.6	17.6	7.6	27.6	17.6	7.6	27.6
C (q'ty)	5	7	8	10	12	13	15	17	18	20	22	23	25	27	28
D	4	6	7	9	11	12	14	16	17	19	21	22	24	26	27

\* Value "C" signifies the number of attached clamp bolts.

### BA31-SG

X-axis: BB30 □ - □□ -M □□ N- □□

Y-axis: BB10 □ - □□ -M □□ N- □□

Common to both ball screw drive type and timing belt drive type.

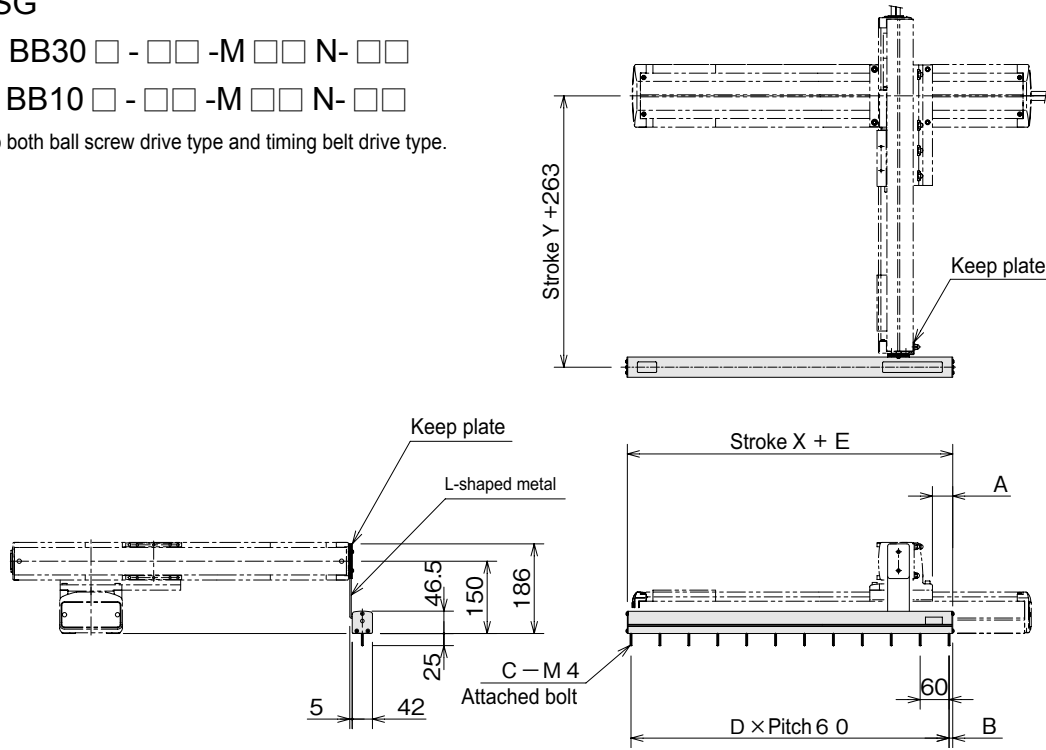

Stroke X (mm)	100	200(150)	300(250)	400(350)	500(450)	600(550)	700(650)	800(750)	900(850)	1000(950)	1100(1050)	1200	1300	1400	1500
A (mm)	17.1 (42.1)														
B (mm)	17.6	7.6	27.6	17.6	7.6	27.6	17.6	7.6	27.6	17.6	7.6	27.6	17.6	7.6	27.6
C (q'ty)	5	7	8	10	12	13	15	17	18	20	22	23	25	27	28
D	4	6	7	9	11	12	14	16	17	19	21	22	24	26	27
E (mm)	176 (226)														

\* The values in parentheses are applicable only when BB30E-ST type (ball screw drive type) is used for the X-axis.

\* Value "C" signifies the number of attached clamp bolts.

### BA53-SG

X-axis: BB50 □ - □□ -M □□ N- □□

Y-axis: BB30 □ - □□ -M □□ N- □□

Common to both ball screw drive type and timing belt drive type.

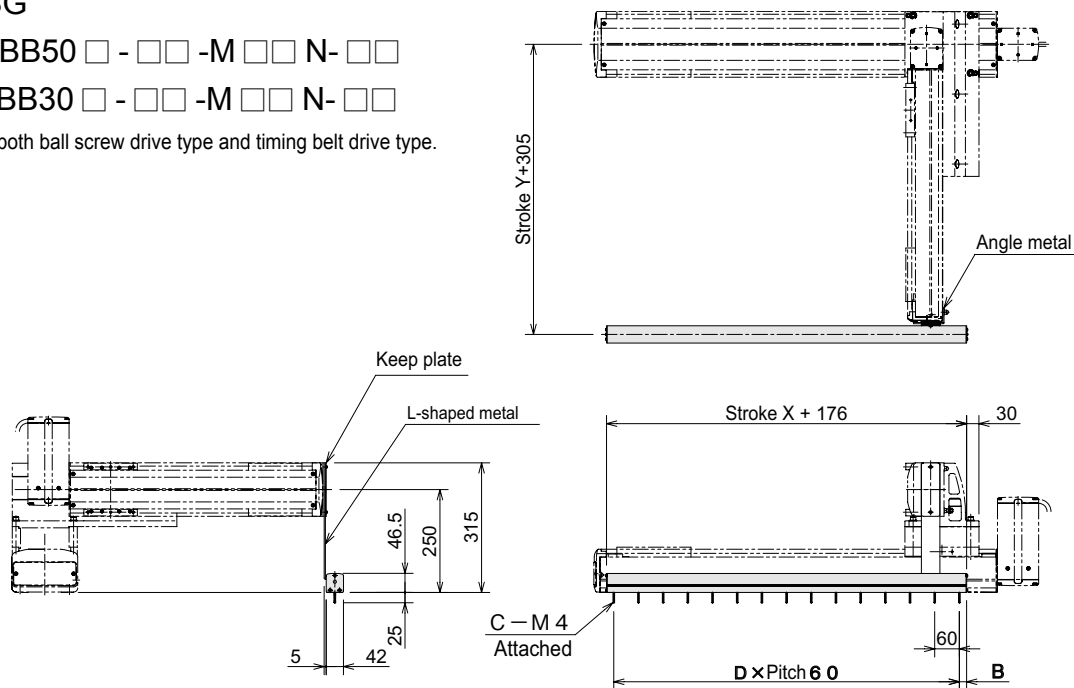

Stroke X (mm)	100	200	300	400	500	600	700	800	900	1000	1100	1200	1300	1400	1500
B (mm)	17.6	7.6	27.6	17.6	7.6	27.6	17.6	7.6	27.6	17.6	7.6	27.6	17.6	7.6	27.6
C (q'ty)	5	7	8	10	12	13	15	17	18	20	22	23	25	27	28
D	4	6	7	9	11	12	14	16	17	19	21	22	24	26	27

\* Value "C" signifies the number of attached clamp bolts.

# Home Position Change Sensor

## [Application]

Used to change the home return position of axis slider to the opposite end to motor side or mid-point of axis stroke. This function is effective when the home position is located at opposite end to motor side. Also, when a traveling axes combination is used, this sensor is required because the home position is located opposite to the motor side.

## [Code designation]

**HBS-BA 10**

Applied axis  
 10: Ball screw driven axis  
 20: Timing belt driven axis

## [Dimensions]

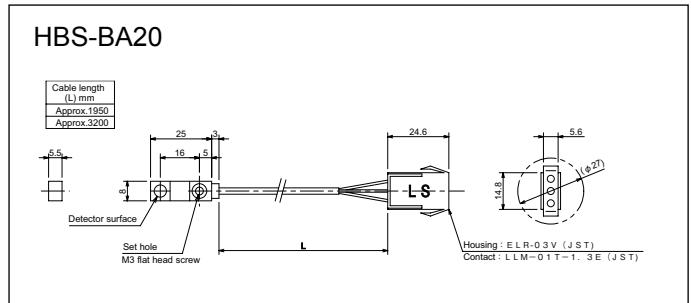
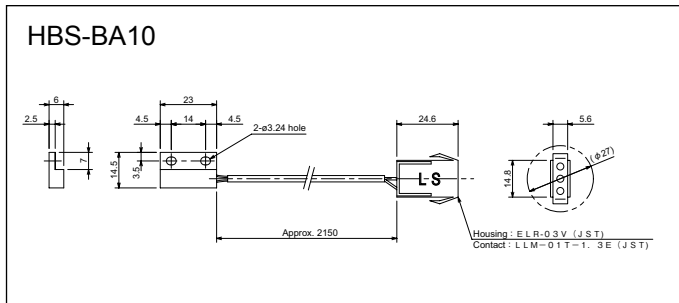

<When home position is located opposite to motor side>

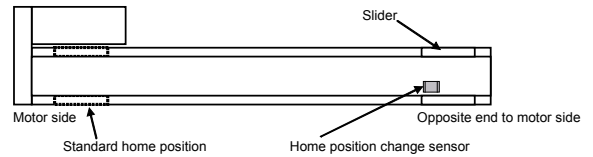

★ Change of controller parameter (motor rotating direction) is required.

<When home position is located at mid-point of axis stroke>

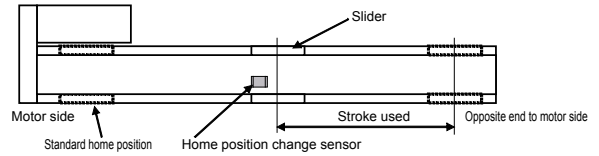

★ Be sure to mount a stopper to prevent the slider from moving by about 3 mm or over toward the motor side from the home position.

# Strain Relief

## [Application]

Used to set in the hole of CN box and secure the wire or tube when user's wire or tube passes through the flexible tube. To mount the strain relief on the CN box, use a hole other than the holes used for controller cable or flexible tube. User's wire and controller cable are joined or branched in the CN box.

## [Code designation]

**BA10 - SC - A 02**

Strain relief

Version  
 Blank

\* Up to four bore sizes of the strain relief are available according to the cable size to be used.

## [Dimension]

Material: Flexible PCV for body  
 Polycarbonate for screw  
 Nylon for nut

	Applicable conduit size (mm)
1st stage	φ 9 ~ 11
2nd stage	φ 11 ~ 14
3rd stage	φ 14 ~ 17
4th stage	φ 17 ~ 19

Dimensions: 36, 42, 59, 39, 15, 31, 23, 40, 7, 6-43, CTG28, 2-stage, 1-stage, 3rd stage, 4th stage, Width across flat, Pan head screw (M4 x 30), CTG28, 2-stage, 1-stage, 3rd stage, 4th stage, Width across flat

Options

# Cable Grip

## [Application]

Used to seal the entry hole of the actuator or CN box to prevent a controller cable from being disconnected or moving in the flexible tube. This grip is intended for securing the controller cable. To secure user's cable, use a strain relief. The cable grip comes in the two types; for two cables of a single axis system and for four cables of a two-axis system.

## [Code designation]

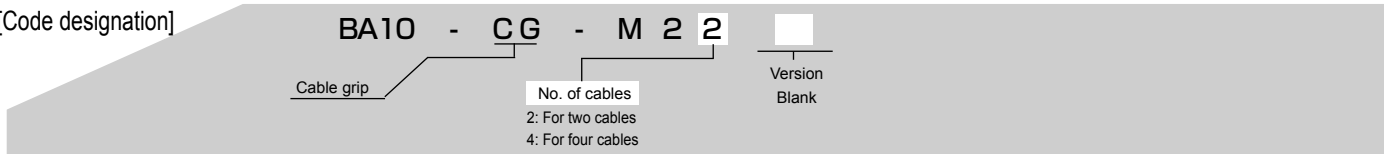

\* A cable grip can be split into two to facilitate passing of a controller cable.

\* The controller cable is equipped with one cable grip for two cables, and the CN box with two cable grips for two cables.

## [Dimensions]

Material: Nylon

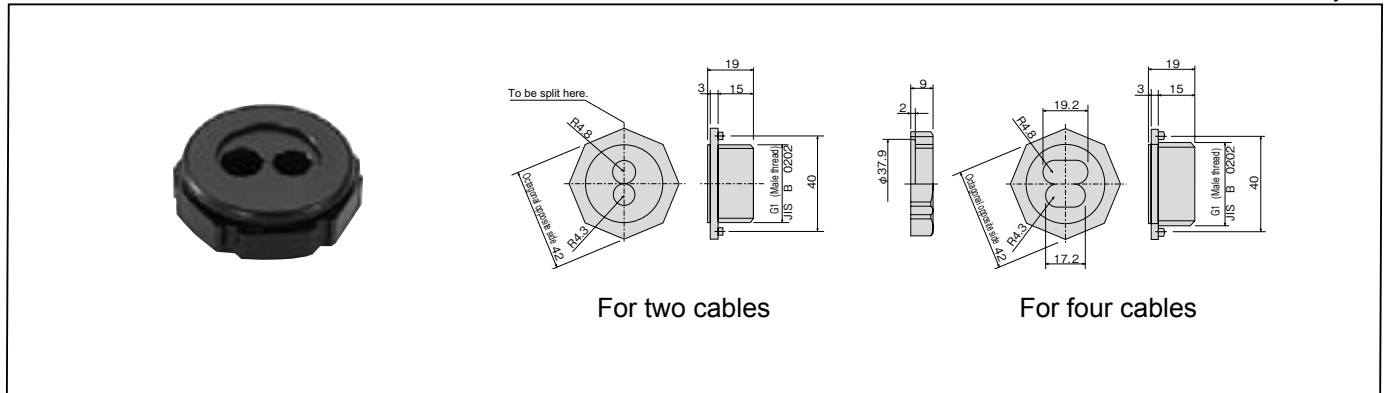

# Parts for Control System

## Controller

Master Unit .....	198
High-Performance Master Unit .....	201
High-Performance Master Unit (Designed for CC-Link) .....	204
Slave Unit .....	207

## Component

Link Cable.....	209
-----------------	-----

## Options

Regeneration Discharge Unit .....	210
Teach Pendant.....	211
Extension I/O Unit.....	212
I/O Cable .....	214
Software for Personal Computer .....	215
Communication Cable .....	216
Memory Card Unit .....	217
Lithium Battery for Encoder Backup .....	217

# Master Unit

- \* Used as the master unit for single-axis control and orthogonal (or cartesian) two-axis control. A driver board for a single axis control is also incorporated.
- \* Easy teaching is possible by a program which is created by using the ROlbot language.
- \* For the supply power, multi power (AC100 V - 120 V, 200 V - 240 V) is used to cope with globalized production.
- \* The pulse train input mode is provided as the special function of the master unit, which allows control of axis travel distance and speed by pulses supplied from an external pulse generator.
- \* The multitask function (No. of controlled axes: 4) is also available, which allows execution of up to four tasks in the sequential mode, two or more jobs can be executed at the same time.
- \* Teach pendant TPH-2A is used.

[Code designation]

CA20 - M 10   

Motor capacity  
10 : 50 ~ 200W  
40 : 400W

Version  
Blank



CA20-M10



CA20-M40

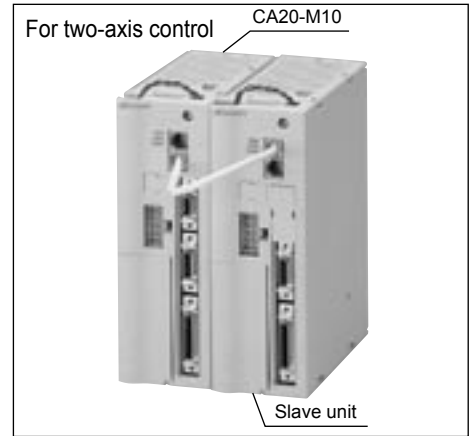

Applicable type of axis  
 CA20-M10 : BB05D、BB07D、BB10E、BB30E、BB30F、BB50F  
 CA20-M40 : BB50G  
 Both the ball screw driven axis and timing belt driven axis of each axis can be controlled.

[System structure]

←→ Basic unit       Extended function unit

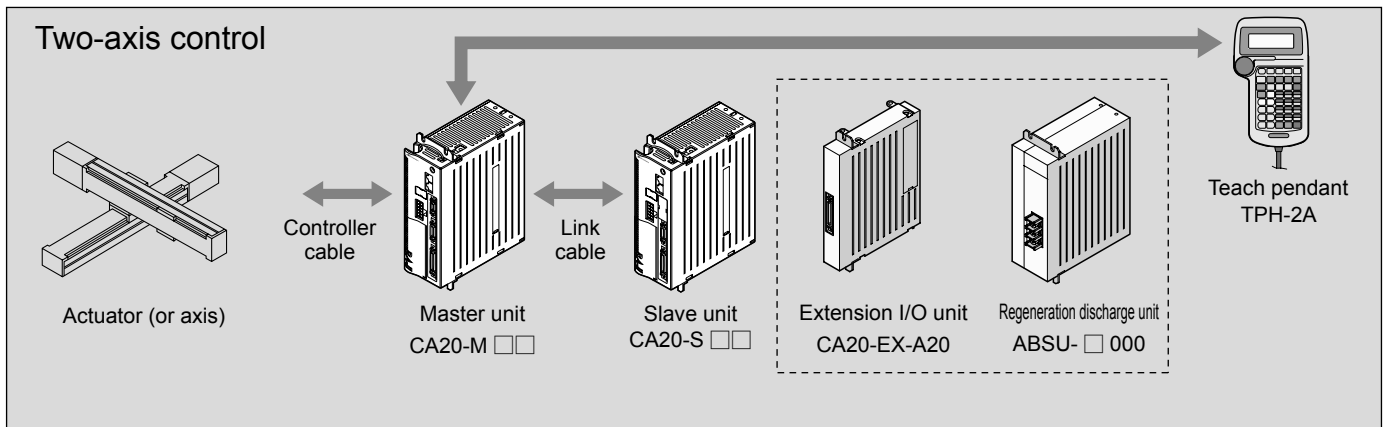
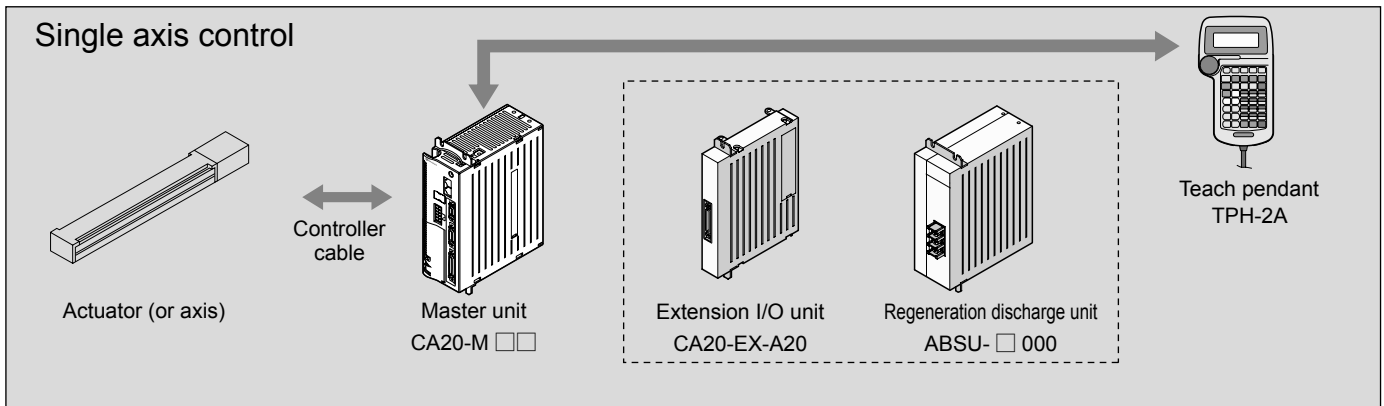



[General specifications]

Type of controller	CA20-M10			CA20-M40 <sup>(Note 1)</sup>
No. of controlled axes	One axis control or simultaneous two-axis control by connecting a slave unit.			
Motor capacity	50W	100W	200W	400W
Drive system	AC servo motor			
Control system	PTP, semi-closed loop control			
Teaching method	Remote teaching, direct teaching or MDI			
Speed setting	10 steps (variable)			
Acceleration setting	20 steps (variable)			
Operation mode	Sequential (multitask), palletizing, external point designation, easy, pulse train input			
Operation method	Step, continuous, single			
CPU	32-bit, RISC SH7145			
Self-diagnosis function	CPU down, memory error, driver error, master power voltage error, program error, etc. by watchdog timers.			
No. of programs	Sequential: 8, Palletizing: 8			
No. of program steps	Max. 2,000 steps + Coordinate table (999 per each task) × 4 (Total No. of tasks) (When slave unit is connected)			
Memory	FRAM			
No. of counters	99			
No. of timers	9			
Alarm display	Error indicator lamp ON (on front panel) and teach pendant display			
External input	4 system inputs and 4 general-purpose inputs			
External output	4 system outputs and 4 general-purpose outputs			
Communication function	For teach pendant × 1 channel (RS232C)			
Power supply	AC100V – 120V, AC200V – 240V, ±10 %, 50/60 Hz Changeover of 100 V or 200 V circuit by short-bar on front terminal block.			AC200V – 230V, ±10% 50/60Hz
Power capacity (per 1 axis)	100VA	160VA	450VA	700VA
Noise resistance	1500 Vp-p, pulse width 1 μs (by noise simulator)			
Ambient conditions	Room temperature 0 - 40°C, humidity 30 % - 90 %RH, non-condensing and no corrosive gas present.			
Dimensions	55 (W) × 160 (H) × 134 (D) (excluding metal fixtures)			85 (W) × 160 (H) × 134 (D) (excluding metal fixtures)
Mass	0.93kg			1.36kg

Note 1:When using CA20-M40, be sure to use regeneration discharge unit ABSU-4000.

[I/O specifications]

Type of: controller: CA20-M10, CA20-M40

Input specifications	
Input rating	DC24 V, 10 mA/ point
Insulation	Bilateral photo-coupler
Power supply	Externally supplied (DC24 V).

Output specifications	
Output	Transistor output (open collector)
Output capacity (DC24 V)	System output: Max. 300 mA/ point General-purpose output: Max. 300 mA/ point

[I/O pin number and signal name]

Type of: controller: CA20-M10, CA20-M40

\* See Pages 231 – 234 of Technical Notes for I/O connections.

Connector pin arrangement on panel side	No.	I/O	Signal name	No.	I/O	Signal name	
<p>(BOTTOM VIEW-)</p>	1		+ COM1	19		COM3	
	2	Output	General-purpose output port 1-1	20	Input	General-purpose input port 1-1	
	3	Output	General-purpose output port 1-2	21	Input	General-purpose input port 1-2	
	4	Output	General-purpose output port 1-3	22	Input	General-purpose input port 1-3	
	5	Output	General-purpose output port 1-4	23	Input	General-purpose input port 1-4	
	6		- COM1	24		NC	
	7		Emergency stop output (N.O)	25		Emergency stop input	
	8		Emergency stop output (COM)	26		Emergency stop input	
	9		Emergency stop output (N.C)	27		COM4	
	10		NC	28	Input	Home return	
	11	Output	Running	-	29	Input	Start
	12	Output	Error	Error	30	Input	Stop
	13	Output	Positioning finish	Positioning finish	31	Input	Reset
	14	Output	Home return finish	-	32		NC
	15	Output	Home position LS	Home position LS	33	Input	+ CLK/±CLK (+)
	16	Output	Z-phase signal	Z-phase signal	34		↑ (-)
	17		- COM2	- COM2	35	Input	- CLK/SIGN (+)
	18		NC		36		↑ (-)

Signals when the pulse train input mode is selected.

NC: No Connection

\* One (1) plug is attached for I/O connector connection. An I/O cable with plug is also available optionally.

## [Dimensions]

Type of controller: CA20-M10

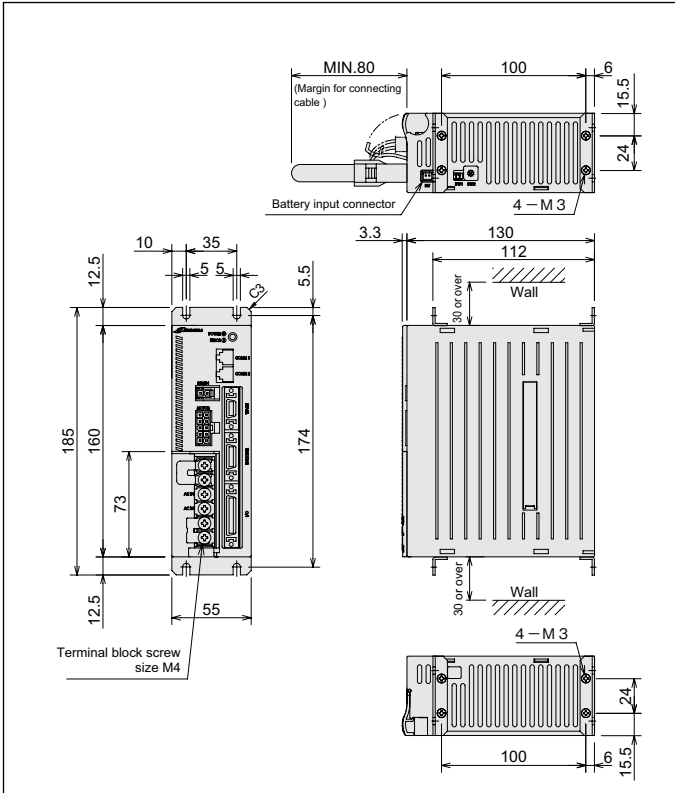

Type of controller: CA20-M40

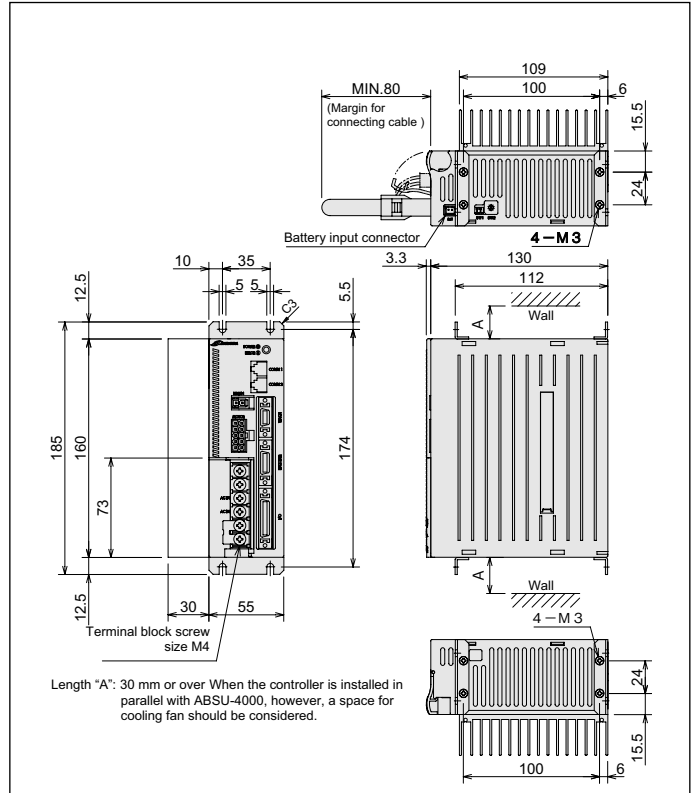

## [Name of each part]

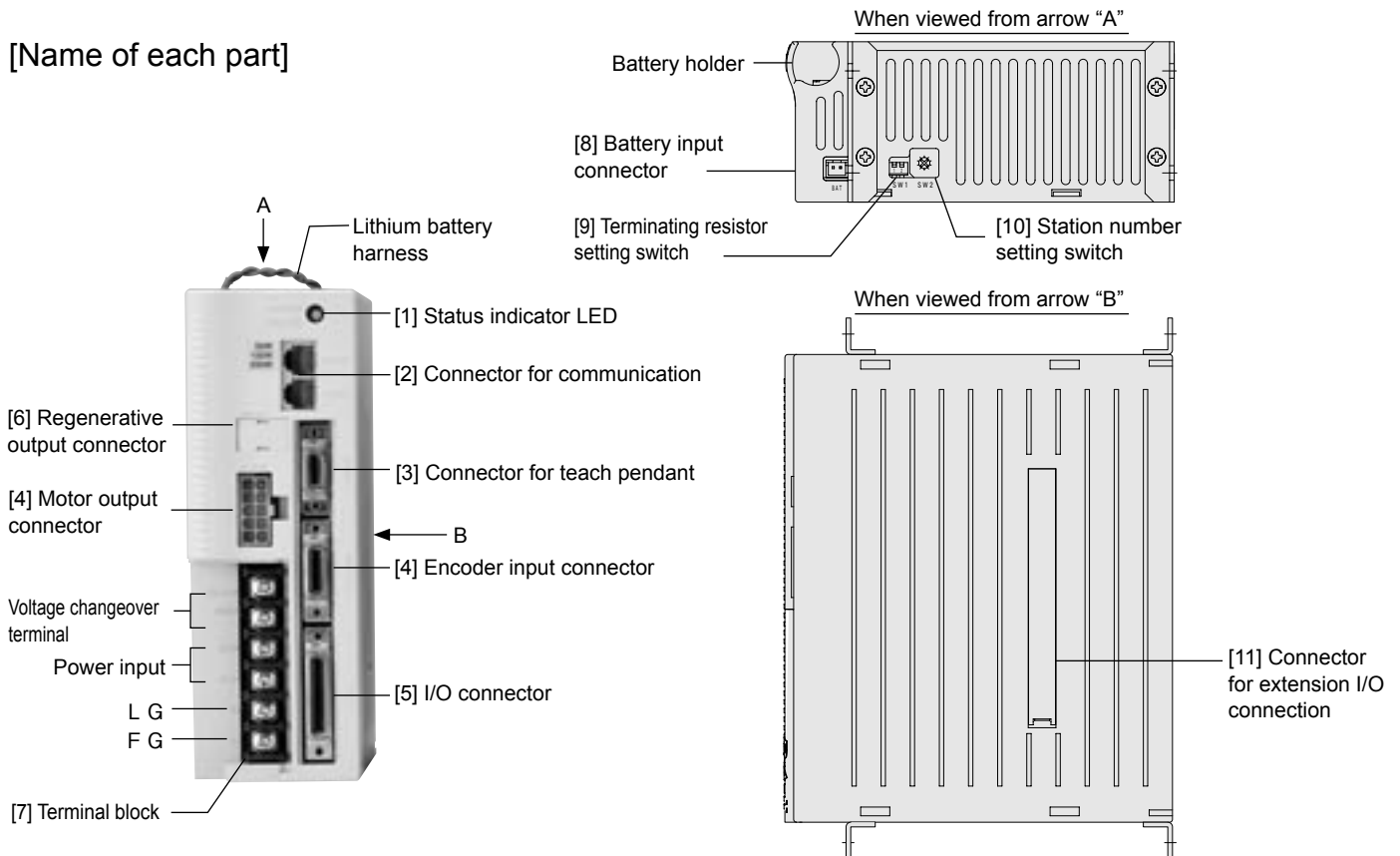

- [1] Status indicator LED  
Indicates the controller status. When the power is turned on, it is illuminated in green. In case of an error, it is illuminated in red.
- [2] Connector for communication  
Used to connect a link cable for connecting a slave unit.
- [3] Connector for teach pendant  
Used to connect a communication cable (option) for connecting the teach pendant or personal computer.
- [4] Motor output connector and encoder input connector  
Used to connect a controller cable.
- [5] I/O connector  
Used to connect an external control device such as sequencer (PLC).
- [6] Regenerative output connector  
Used to connect a regeneration discharge unit (option). To connect, remove the cover.

- [7] Terminal block  
A power input terminal, master power voltage changeover terminal, FG (frame ground) and LG (line ground) terminals are equipped.
- [8] Battery input connector  
Used to connect a lithium battery for encoder backup. This connector is used when an absolute encoder is used.
- [9] Terminating resistor setting switch  
Used to set the terminating resistor for communication when a slave unit is connected.
- [10] Station number setting switch  
Used to specify the station number of each slave unit when slave units are connected to control multiple axes. Specify zero (0) for the master unit.
- [11] Connector for extension I/O connection  
Used to connect an extension I/O unit (option). To connect, remove the cover.

# High-Performance Master Unit

- \* Up to four axes can be controlled simultaneously. It is used as the master unit in a single-axis to four-axis system.
- \* As driver unit for axis drive is not incorporated in this master unit, driver units (slave units) for the number of controlled axes are necessary.
- \* Two-dimensional and three-dimensional linear interpolation, circular interpolation and pass functions are available. Useful for work, attaching importance to axis loci.
- \* While the robot is moving, general-purpose control can be turned on and off at specified coordinates. (Instruction word: OUTS)
- \* A specified coordinate can be changed to a coordinate received via RS232C communication while the axis is moving toward the former coordinate. (Instruction word: RSMV)
- \* The multitask function is also available, which allows execution of up to four tasks for input/output control in the sequential mode. (For axis motion, only one task can be used.)
- \* Teach pendant TPH-4B is used.

[Code designation]

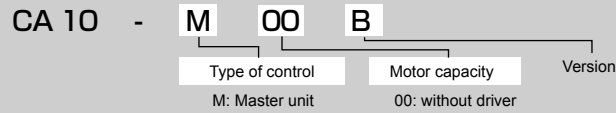

CA10-M00B

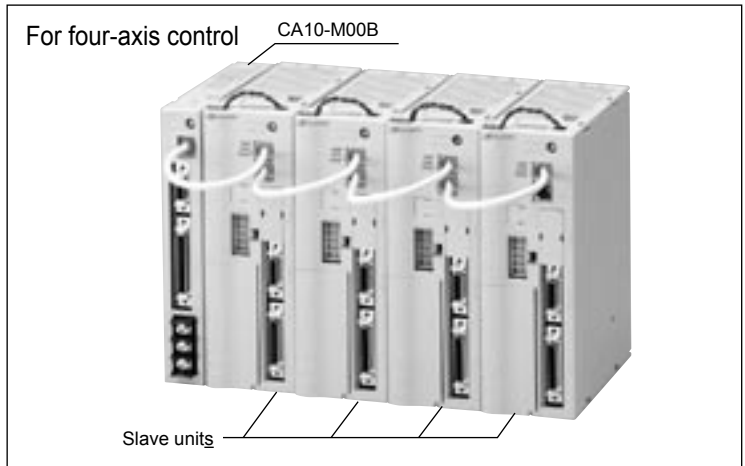

Applicable type of axis  
 BB05D、BB07D、BB10E、BB30E、BB30F、BB50F、BB50G  
 Both the ball screw driven axis and timing belt driven axis of each axis can be controlled.

[System structure]

↔ Basic unit    [---] Extended function unit

## Single axis to four axes control

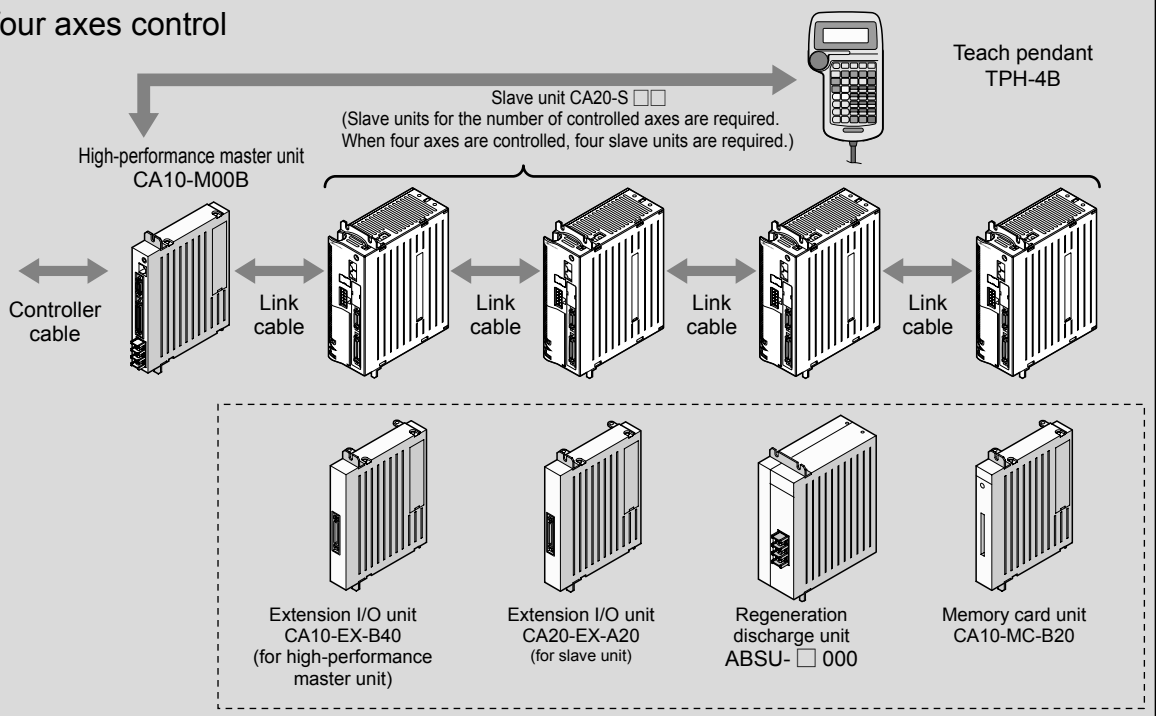
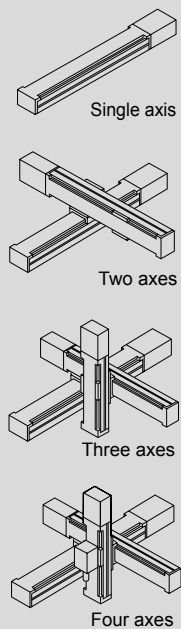

Controller

## [General specifications]

Type of controller		CA10-M00B	
No. of controlled axes	One axis control or simultaneous control of up to four axes by connecting slave units.	Self-diagnosis function	CPU down, memory error, driver error, master power voltage error, program error, etc.
Control system	CP control, PTP control, semi-closed loop control	Alarm display	Error indicator LED and teach pendant display
Interpolation	Three-dimensional linear interpolation and circular interpolation	External input	4 system inputs and 20 general-purpose inputs
Encoder signal	Line driver communication	External output	4 system outputs and 12 general-purpose outputs
Teaching method	Remote teaching, direct teaching or MDI	Communication function	1 CH (RS232C), shared with a teach pendant
Speed and acceleration	Speed: 10 steps (variable) Acceleration: 20 steps (variable)	Extension I/O	Extension unit: 24 inputs and 16 outputs One unit can be connected with a master unit.
Operation method	Step, continuous, single	Power supply for driving external device	Output power supply is not available. (Power is supplied externally.)
Operation mode	Sequential (multitask) (Note 1) Palletizing Easy External point designation	Emergency stop I/O	No-voltage input (contact input) and relay C contact output
No. of programs	Sequential: 16, Palletizing: 16, Easy: 8	Master power voltage	DC24V±10%, 0.5 A (externally supplied)
No. of steps	Max. 2,500 steps (Note 2)	Noise resistance	1500 Vp-p, pulse width 1 μs (by noise simulator)
Coordinate table	Each task: 999	Ambient conditions	Room temperature 0 – 40°C, humidity 30% – 90%RH, non-condensing and no corrosive gas present.
No. of counters	99	Dimensions	25 (W) × 160 (H) × 134 (D) (excluding metal fixtures)
No. of timers	9	Mass	0.4 kg
Memory	EEPROM (without battery)		
CPU	32-bit (RISC CPU, SH7051)		

Note 1: Multitask: Up to four tasks (one task only for axis control) are available. Note 2: Varies with a mode to be used

## [I/O specifications]

Type of: controller: CA10-M00B

Input specifications	
Input rating	DC24 V, 10 mA/1 point
Insulation	Photo-coupler
Power supply	Externally supplied (DC24 V).

Output specifications	
Output	Transistor output (open collector)
Output capacity (DC24 V)	System output: Max. 20 mA/ point General-purpose output: Max. 300 mA/ point

## [I/O pin number and signal name]

Type of: controller: CA10-M00B

\* See Pages 235 – 236 of Technical Notes for I/O connections.

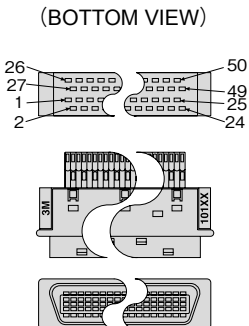
Connector pin arrangement on panel side	No.	I/O	Signal name	No.	I/O	Signal name
 <p>(BOTTOM VIEW)</p>	1		+COM1	26	Input	General-purpose input port 1-1
	2	Output	General-purpose output port 1-1	27	Input	General-purpose input port 1-2
	3	Output	General-purpose output port 1-2	28	Input	General-purpose input port 1-3
	4	Output	General-purpose output port 1-3	29	Input	General-purpose input port 1-4
	5	Output	General-purpose output port 1-4	30	Input	General-purpose input port 1-5
	6	Output	General-purpose output port 1-5	31	Input	General-purpose input port 1-6
	7	Output	General-purpose output port 1-6	32	Input	General-purpose input port 1-7
	8	Output	General-purpose output port 1-7	33	Input	General-purpose input port 1-8
	9	Output	General-purpose output port 1-8	34	Input	General-purpose input port 2-1
	10	Output	General-purpose output port 2-1	35	Input	General-purpose input port 2-2
	11	Output	General-purpose output port 2-2	36	Input	General-purpose input port 2-3
	12	Output	General-purpose output port 2-3	37	Input	General-purpose input port 2-4
	13	Output	General-purpose output port 2-4	38	Input	General-purpose input port 2-5
	14		-COM1	39	Input	General-purpose input port 2-6
	15		-COM1	40	Input	General-purpose input port 2-7
	16		+COM2	41	Input	General-purpose input port 2-8
	17	Output	Running	42	Input	General-purpose input port 3-1
	18	Output	Error	43	Input	General-purpose input port 3-2
	19	Output	Positioning finish	44	Input	General-purpose input port 3-3
	20	Output	Home return finish	45	Input	General-purpose input port 3-4
	21	Input	Home return	46		Emergency stop input
	22	Input	Start	47		Emergency stop input
	23	Input	Stop	48		Emergency stop output (NO)
	24	Input	Reset	49		Emergency stop output (COM)
	25		-COM2	50		Emergency stop output (NC)

Note 1: No internal connection between +COM1 and +COM2, or between -COM1 and -COM2.

\* One (1) plug is attached for I/O connector connection. An I/O cable with plug is also available optionally.

[Dimensions]

Type of controller: CA10-M00B

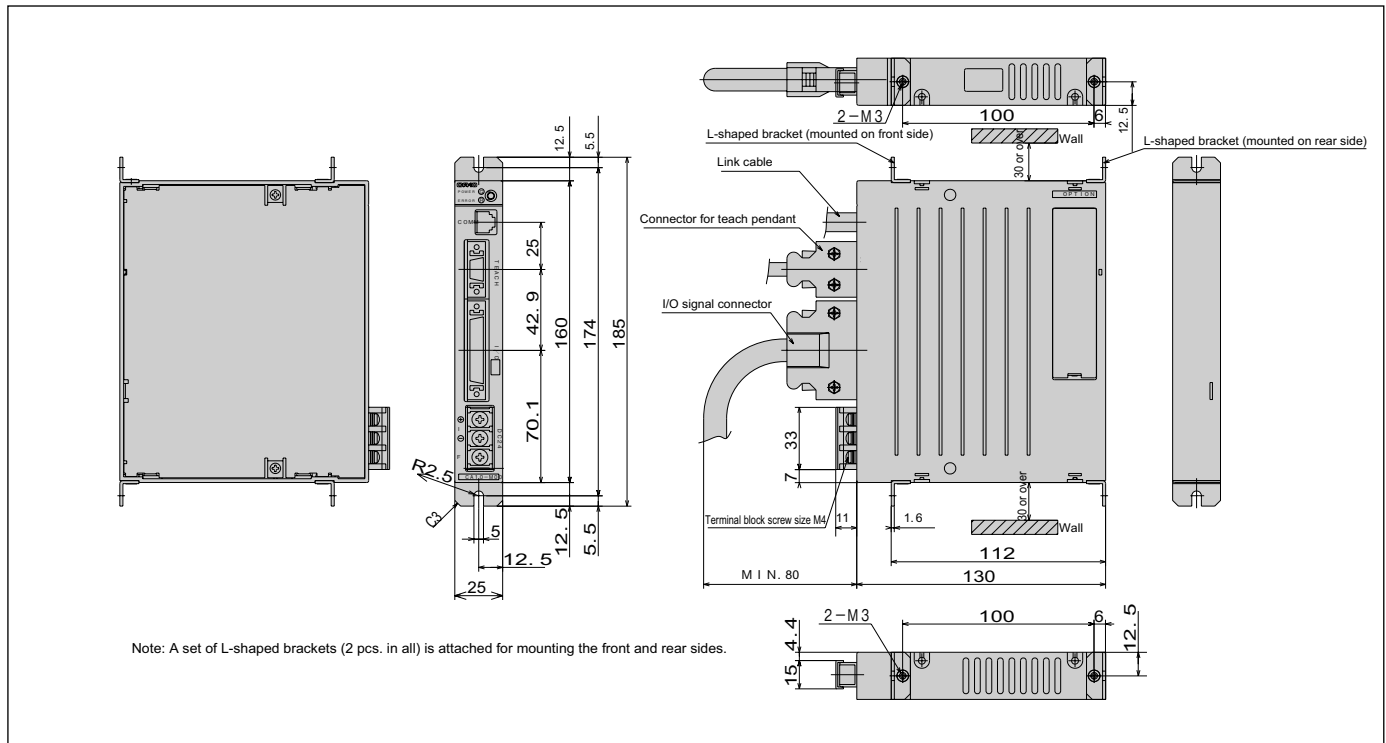

[Name of each part]

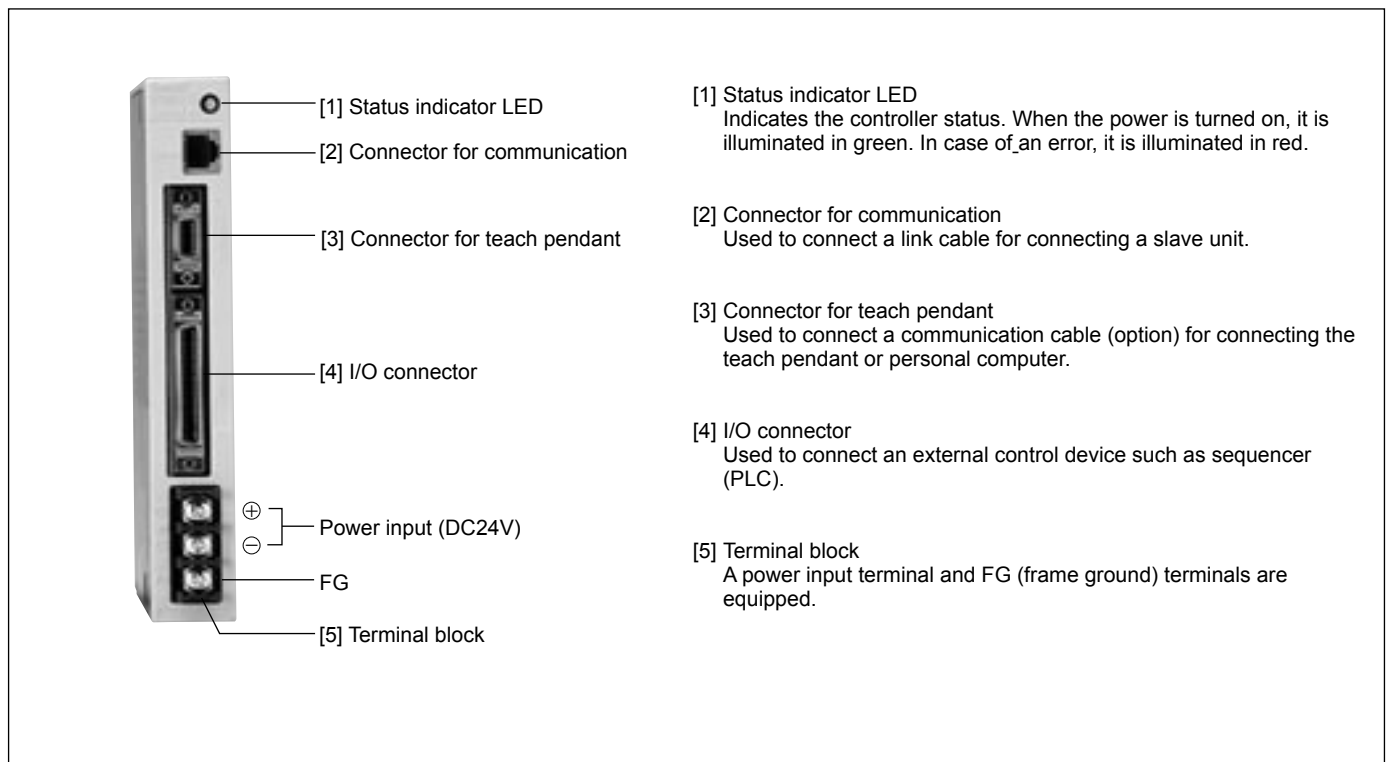

Controller

# High-Performance Master Unit (Designed for CC-Link)

- \* This is the controller which adds the network function to high-performance master unit CA10-M00B.
- \* Interface with an external device can be established via CC-Link.  
The CC-Link (i.e., Control & Communication Link) is a field network interface which realizes wire-saving and high-speed data communication.
- \* It is possible to perform data communication of each I/O, coordinate table, status and jog motion through the CC-Link interface.
- \* For the RS232C interface, two channels are provided (one channel for the teach pendant) as standard.
- \* The operation other than the network function is the same as in the CA10-M00B.
- \* Teach pendant TPH-4B is used.

[Code designation]

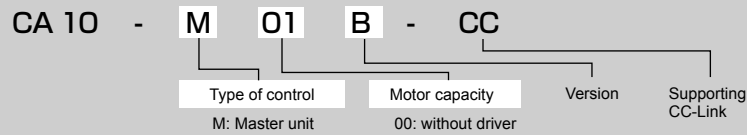

CA10-M01B-CC

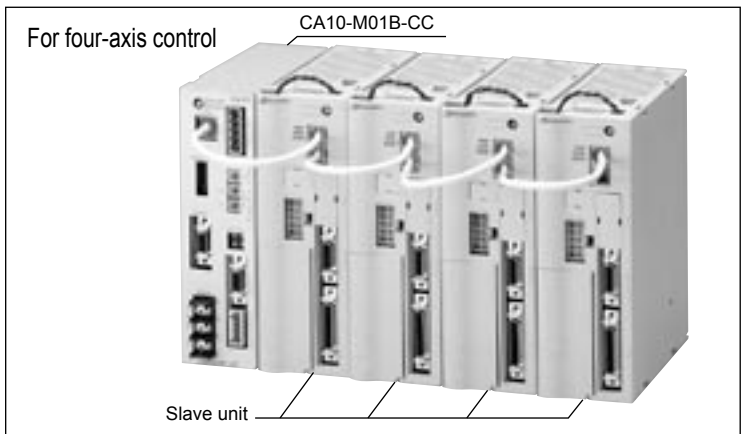

Applicable type of axis  
 BB05D、BB07D、BB10E、BB30E、BB30F、BB50F、BB50G  
 Both the ball screw driven axis and timing belt driven axis of each axis can be controlled.

[System structure]

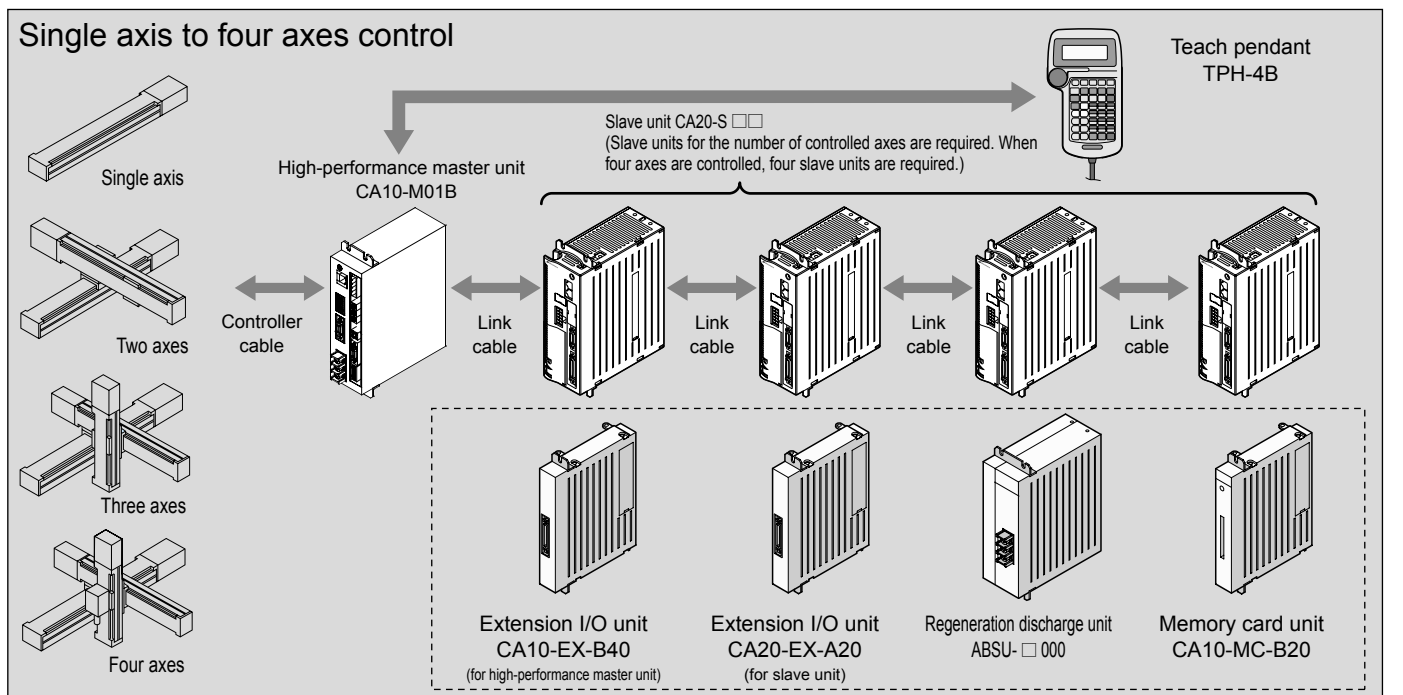

Controller

[General specifications]

Type of controller		CA10-M01B	
No. of controlled axes	One axis control or simultaneous control of up to four axes by connecting slave units.	Self-diagnosis function	CPU down, memory error, driver error, master power voltage error, program error, etc.
Control system	CP control, PTP control, semi-closed loop control	Alarm display	Error LED ON and teach pendant display
Interpolation	Three-dimensional linear interpolation and circular interpolation	External input	See the CC-Link interface specifications.
Encoder signal	Line driver communication	External output	See the CC-Link interface specifications.
Teaching method	Remote teaching, direct teaching or MDI	Communication function	1 channel each for teach pendant and RS232C.
Speed and acceleration	Speed: 10 steps (variable) Acceleration: 20 steps (variable)	Extension I/O	Extension unit: 24 inputs and 16 outputs One unit can be connected with a master unit.
Operation method	Step, continuous, single	Power supply for driving external device	Output power supply is not available. (Power is supplied externally.)
Operation mode	Sequential (multitask) (Note 1) Palletizing Easy External point designation	Emergency stop I/O	No-voltage input (contact input) and relay C contact output
No. of programs	Sequential: 16, Palletizing: 16, Easy: 8	Master power voltage	DC24V±10 %, 0.5 A (externally supplied)
No. of steps	Max. 2,500 steps (Note 2)	Noise resistance	1500 Vp-p, pulse width 1 μs (by noise simulator)
Coordinate table	Each task: 999	Ambient conditions	Room temperature 0 – 40°C, humidity 30 % – 90 %RH, non-condensing and no corrosive gas present.
No. of counters	99	Dimensions	47 (W) × 160 (H) × 130 (D) (excluding metal fixtures)
No. of timers	9	Mass	0.8 kg
Memory	EEPROM (without battery)		
CPU	32-bit (RISC CPU, SH7051)		

Note 1: Multitask: Up to four tasks (only one task for axis control) are available. Note 2: Varies with a mode to be used.

[CC-Link interface specifications]

Item	Specification
Transmission	CC-Link Ver1.10
Baudrate	10 M/5 M/2.5 M/625 k/156 kbps (To be set by rotary switch.)
Type of station	Remote device station
No. of stations occupied	4 stations (predetermined) (RS/RX: 128 points each, RWw/RWr: 16 points each)
Station number setting	1 – 64 (To be set by rotary switch.)
No. of inputs/outputs	4 system inputs/4 system outputs
	64 general-purpose inputs/64 general-purpose outputs
	8 jog inputs/8 jog outputs
	1 handshake input/2 handshake outputs
Data communication function	Transmission of coordinate table, current position monitor, request for error code and status, etc.

[I/O signal table]

\* See Pages 237 – 238 of Technical Notes for I/O connections.

Signal direction: CC-Link master station ← CA10-M01-CC		Signal direction: CC-Link master station → CA10-M01-CC	
Device No. (Input)	Signal name	Device No. (Input)	Signal name
RXn0	Output during running	RYn0	Home return input
RXn1	Error output	RYn1	Start input
RXn2	Positioning finish output	RYn2	Stop input
RXn3	Home return finish output	RYn3	Reset input
RXn4 – RXn7	–	RYn4 – RYn7	–
RXn8 – RXnF	General-purpose output port 1-1 – 8	RYn8 – RYn F	General-purpose input port 1-1 – 8
RX(n+1)0 – RX(n+1)7	General-purpose output port 2-1 – 8	RY(n+1)0 – RY(n+1)7	General-purpose input port 2-1 – 8
RX(n+1)8 – RX(n+1)F	General-purpose output port 3-1 – 8	RY(n+1)8 – RY(n+1)F	General-purpose input port 3-1 – 8
RX(n+2)0 – RX(n+2)7	General-purpose output port 4-1 – 8	RY(n+2)0 – RY(n+2)7	General-purpose input port 4-1 – 8
RX(n+2)8 – RX(n+2)F	General-purpose output port 5-1 – 8	RY(n+2)8 – RY(n+2)F	General-purpose input port 5-1 – 8
RX(n+3)0 – RX(n+3)7	General-purpose output port 6-1 – 8	RY(n+3)0 – RY(n+3)7	General-purpose input port 6-1 – 8
RX(n+3)8 – RX(n+3)F	General-purpose output port 7-1 – 8	RY(n+3)8 – RY(n+3)F	General-purpose input port 7-1 – 8
RX(n+4)0 – RX(n+4)7	General-purpose output port 8-1 – 8	RY(n+4)0 – RY(n+4)7	General-purpose input port 8-1 – 8
RX(n+4)8 – RX(n+4)F	Jog output	RY(n+4)8 – RY(n+4)F	Jog input
RX(n+5)0 – RX(n+5)7	Reserved	RY(n+5)0 – RY(n+5)7	Reserved
RX(n+5)8 – RX(n+5)F		RY(n+5)8 – RY(n+5)F	
RX(n+6)0 – RX(n+6)7		RY(n+6)0 – RY(n+6)7	
RX(n+6)8	Command processing finish (*)	RY(n+6)8	Command processing request (*)
RX(n+6)9	Command error (*)	RY(n+6) 9	–
RX(n+6)A – RX(n+6)F	–	RY(n+6)A – RY(n+6)F	–
RX(n+7)0 – RX(n+7)7	–	RY(n+7)0 – RY(n+7)7	–
RX(n+7)8 – RX(n+7)F	–	RY(n+7)8 ~ RY(n+7)F	–

n: Addresses assigned to the master unit by station number setting.

(\*) Handshake signals for data communication.

## [Dimensions]

Type of controller: CA10-M01B-CC

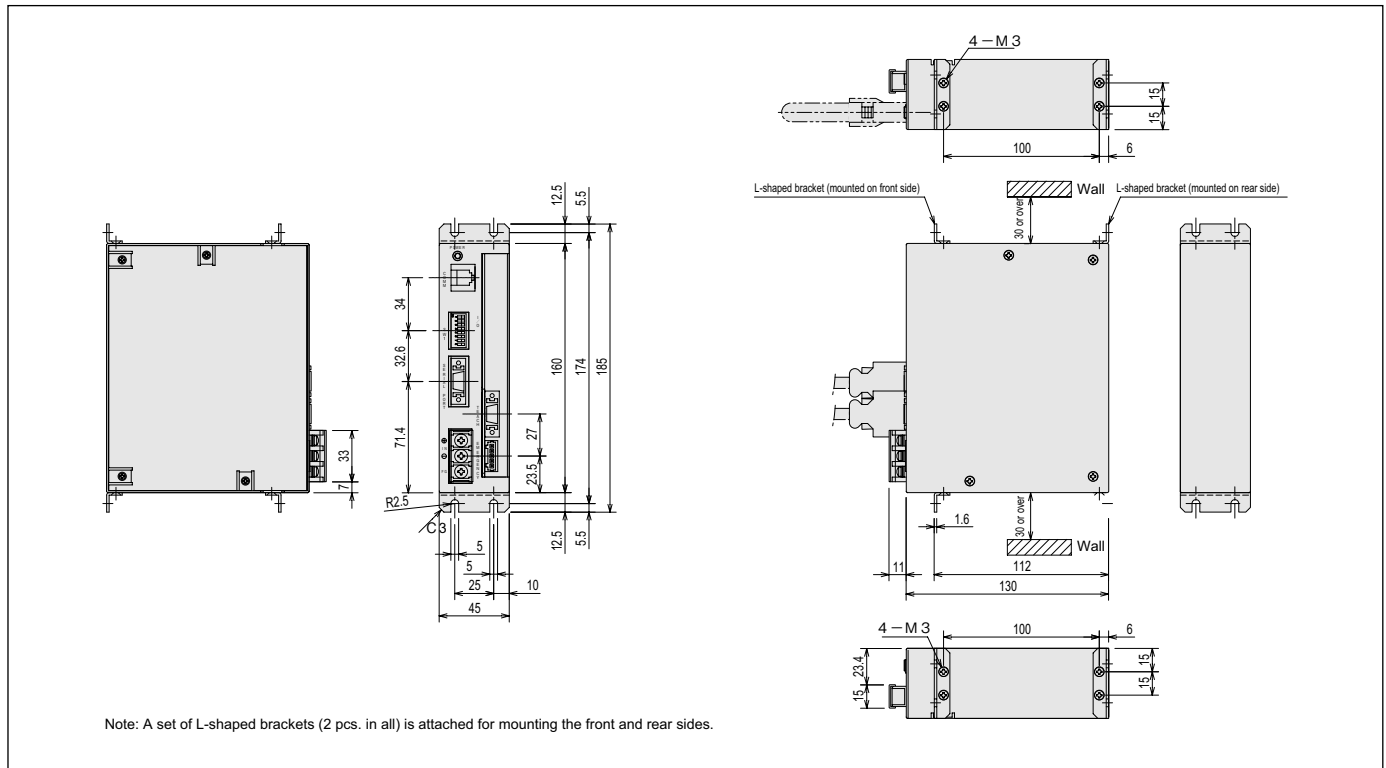

## [Name of each part]

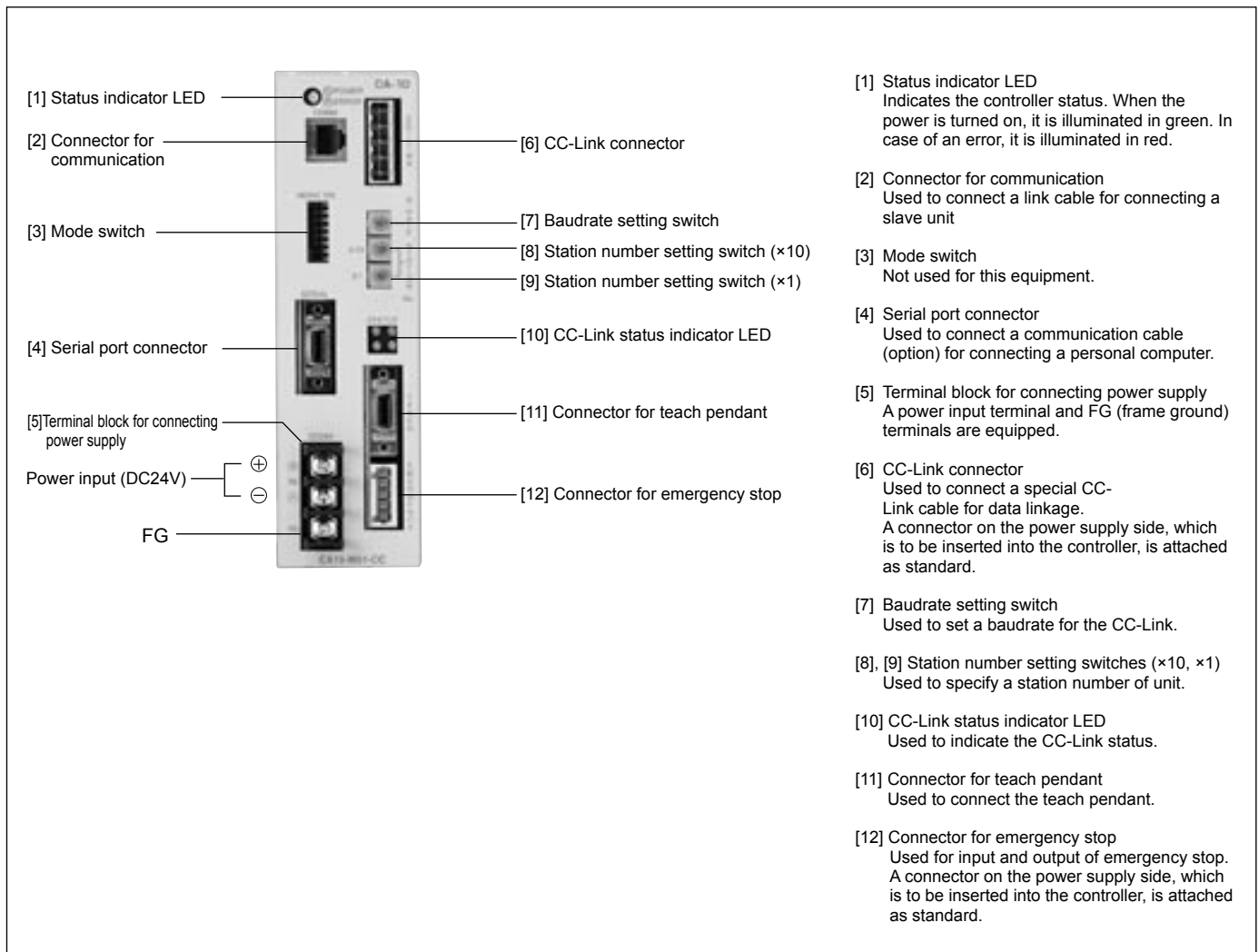

- [1] Status indicator LED  
Indicates the controller status. When the power is turned on, it is illuminated in green. In case of an error, it is illuminated in red.
- [2] Connector for communication  
Used to connect a link cable for connecting a slave unit
- [3] Mode switch  
Not used for this equipment.
- [4] Serial port connector  
Used to connect a communication cable (option) for connecting a personal computer.
- [5] Terminal block for connecting power supply  
A power input terminal and FG (frame ground) terminals are equipped.
- [6] CC-Link connector  
Used to connect a special CC-Link cable for data linkage. A connector on the power supply side, which is to be inserted into the controller, is attached as standard.
- [7] Baudrate setting switch  
Used to set a baudrate for the CC-Link.
- [8], [9] Station number setting switches (×10, ×1)  
Used to specify a station number of unit.
- [10] CC-Link status indicator LED  
Used to indicate the CC-Link status.
- [11] Connector for teach pendant  
Used to connect the teach pendant.
- [12] Connector for emergency stop  
Used for input and output of emergency stop. A connector on the power supply side, which is to be inserted into the controller, is attached as standard.



## Slave Unit

- \* Used as an auxiliary unit when controlling the master unit or high-performance master unit.
- \* A driver unit for one axis control is built in this unit.
- \* For the supply power, multi power (AC100 V – 120 V, 200 V – 240 V) is used to cope with globalized production.



CA20-S10



CA20-S40

Applicable type of axis  
 CA20-S10 : BB05D、BB07D、BB10E、BB30E、BB30F、BB50F  
 CA20-S40 : BB50G  
 Both the ball screw driven axis and timing belt driven axis of each axis can be controlled.

### [Code designation]

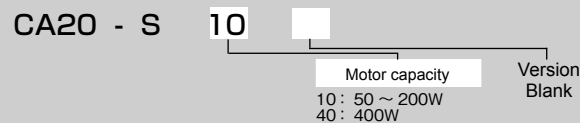

\* One (1) plug for connecting an I/O connector is attached to the slave unit. An I/O cable with plug is also available optionally.

### [General specifications]

Type of controller	CA20-S10			CA20-S40 (Note 1)
No. of controlled axes	One axis control by connecting with a master unit.			
Motor capacity	50W	100W	200W	400W
Drive system	AC servo motor			
Alarm display	Error indicator lamp ON (on front panel) and teach pendant display (connected with a master unit)			
External input	8 points			
External output	8 points			
Power supply	AC100V – 120V, AC200V – 240V, ±10 %, 50/60 Hz Changeover of 100 V or 200 V circuit by short-bar on front terminal block.			
Power capacity (per 1 axis)	100VA	160VA	450VA	700VA
Noise resistance	1500 Vp-p, pulse width 1 μs (by noise simulator)			
Ambient conditions	Room temperature 0 – 40°C, humidity 30 % – 90 %RH, non-condensing and no corrosive gas present.			
Dimensions	55 (W) × 160 (H) × 134 (D) (excluding metal fixtures)			85 (W) × 160 (H) × 134 (D) (excluding metal fixtures)
Mass	0.91kg			1.34kg

Note 1: When using CA20-S40, be sure to use regeneration discharge unit ABSU-4000.

### [I/O specifications]

Type of: controller: CA20-S10, CA20-S40

Input specifications	
Input rating	DC24 V, 10 mA/1 point
Insulation	Bilateral photo-coupler
Power supply	Externally supplied (DC24 V).

Output specifications	
Output	Transistor output (open collector)
Output capacity (DC24 V)	General-purpose output 1-1 through 1-8: Max. 300 mA/ point

[I/O pin number and signal name]

Type of controller: CA20-S10, CA20-S40

\* See Page 239 of Technical Notes for I/O connections.

Connector pin arrangement on panel side	No.	I/O	Signal name	No.	I/O	Signal name
<p>(Bottom view)</p>	1		+COM1	19		COM3
	2	Output	General-purpose output port 1-1	20	Input	General-purpose input port 1-1
	3	Output	General-purpose output port 1-2	21	Input	General-purpose input port 1-2
	4	Output	General-purpose output port 1-3	22	Input	General-purpose input port 1-3
	5	Output	General-purpose output port 1-4	23	Input	General-purpose input port 1-4
	6		-COM1	24		NC
	7		Emergency stop output (N.O)	25		NC
	8		Emergency stop output	26		NC
	9		Emergency stop output (N.C)	27		COM4
	10		NC	28	Input	General-purpose input port 1-5
	11	Output	General-purpose output port 1-5	29	Input	General-purpose input port 1-6
	12	Output	General-purpose output port 1-6	30	Input	General-purpose input port 1-7
	13	Output	General-purpose output port 1-7	31	Input	General-purpose input port 1-8
	14	Output	General-purpose output port 1-8	32		NC
	15		NC	33		NC
	16		NC	34		NC
	17		-COM2	35		NC
	18		NC	36		NC

[Dimensions]

NC: No Connection

Type of controller: CA20-S10

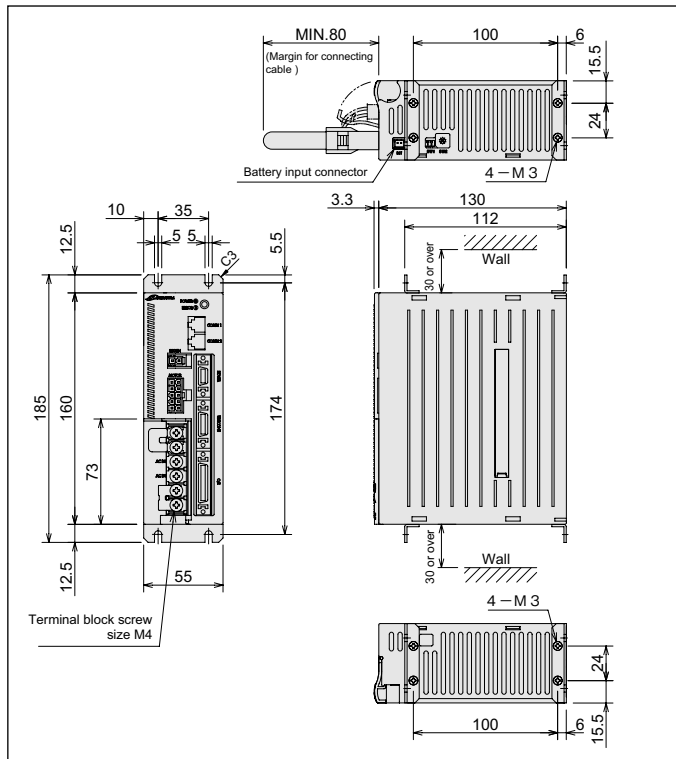

Type of controller: CA20-S40

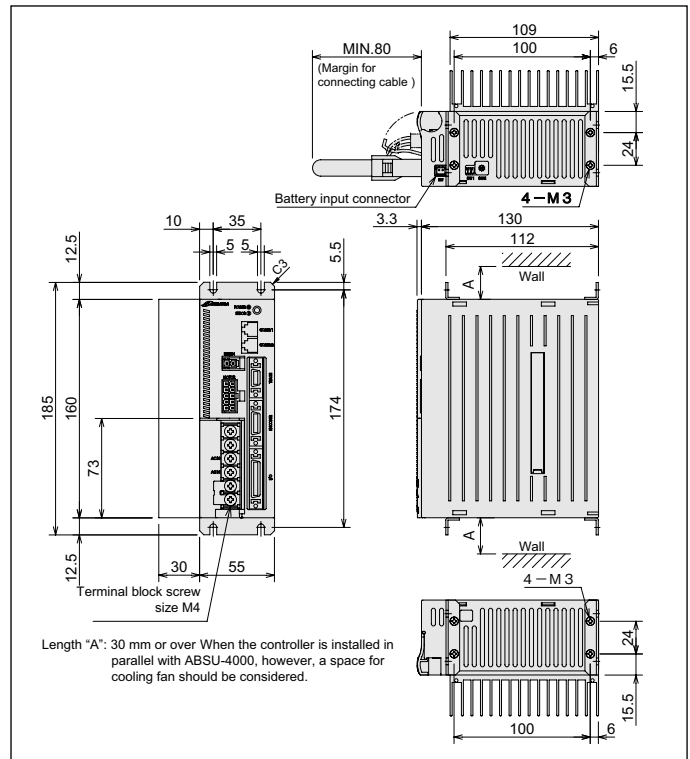

Controller

[Name of each part]

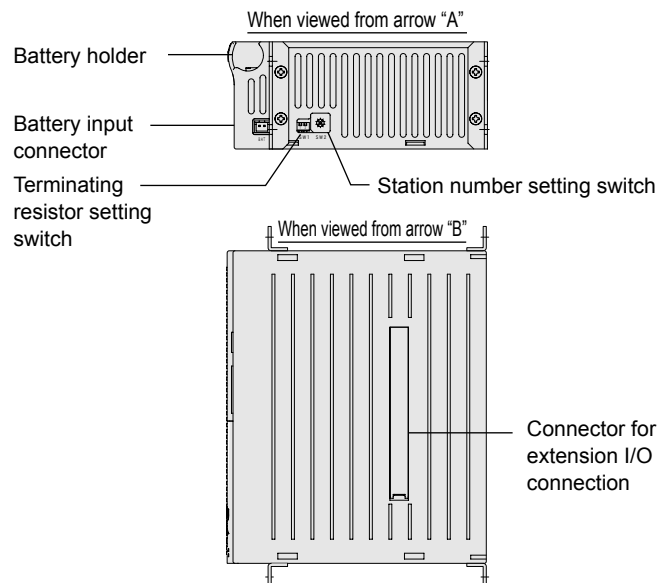
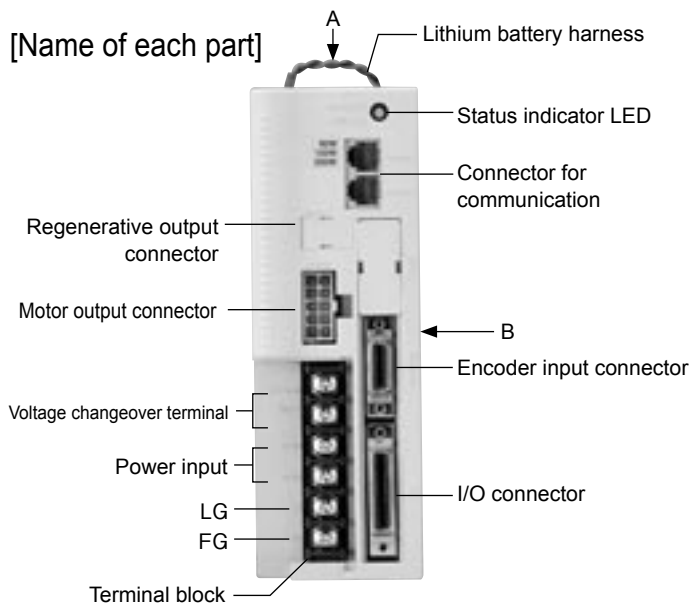

For details on each part, see the descriptions on the master unit on Page 200.

# Link Cable

## [Application]

Used for communication between the master unit serving as the main controller and the slave unit which operates under commands given from the main controller.  
 This cable is not required when a signal axis is controlled and only the master unit is used.  
 This link cable connects the master unit with each slave unit in series.  
 The cable length differs when the master and slave units are mounted closely and when they are installed separately from each other.



## [Code designation]

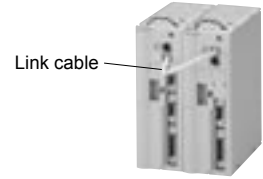
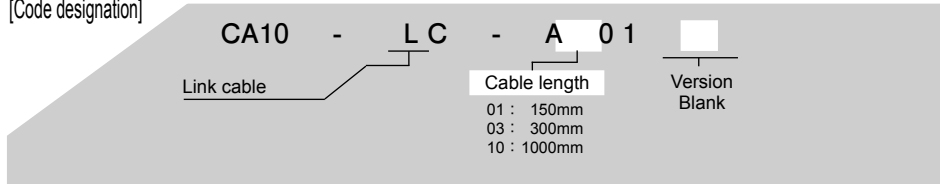

- \* A link cable must not be bundled together with other signal cables or must not run in the same cable (or wire) duct where other cables run.
- \* A link cable is equipped with plugs on both ends. It cannot be cut or reworked.

## [Dimensions]

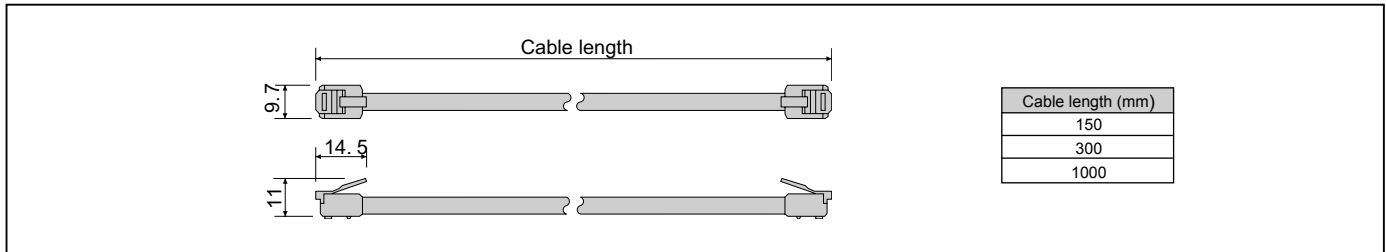

# Regeneration Discharge Unit

## [Application]

The regeneration discharge unit is designed to absorb excess energy generated in an actuator (or axis) motor during deceleration. The unit is useful when load inertia exceeds the tolerance, or when a heavy load is descended along the Z-axis over a long stroke (generating excessive electricity). (The unit prevents overvoltage generated in the controller.)

ABSU-2000

ABSU-4000



## [Code designation]

A B S U - 2 0 0 0

Applicable controller  
 2 : CA20-M10 · CA20-S10  
 4 : CA20-M40 · CA20-S40

\* All discharge energy is converted into heat.

\* If the discharge circuit of the regeneration discharge unit has overheated, it is signaled by contact output (N.C).

\* One unit is needed per axis, and can be connected to the master or slave unit when necessary.

## [Dimensions]

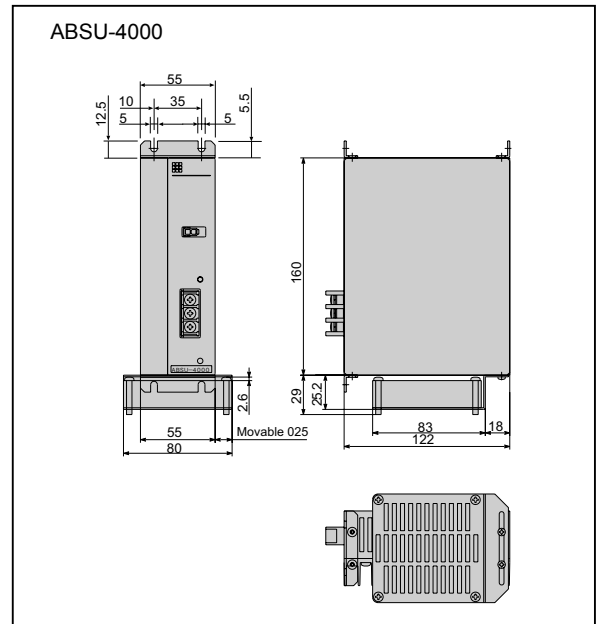
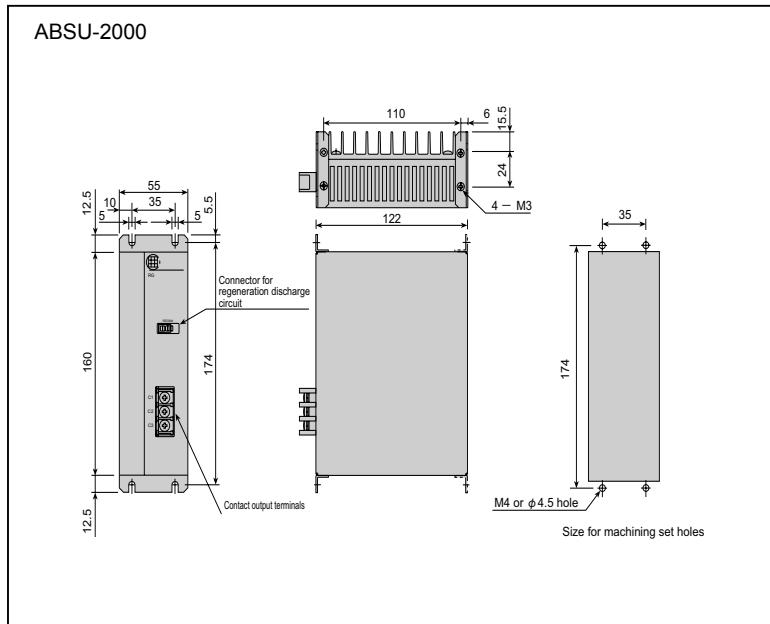

Accessories: L-shaped bracket, cable (300 mm)

## [Example connection]

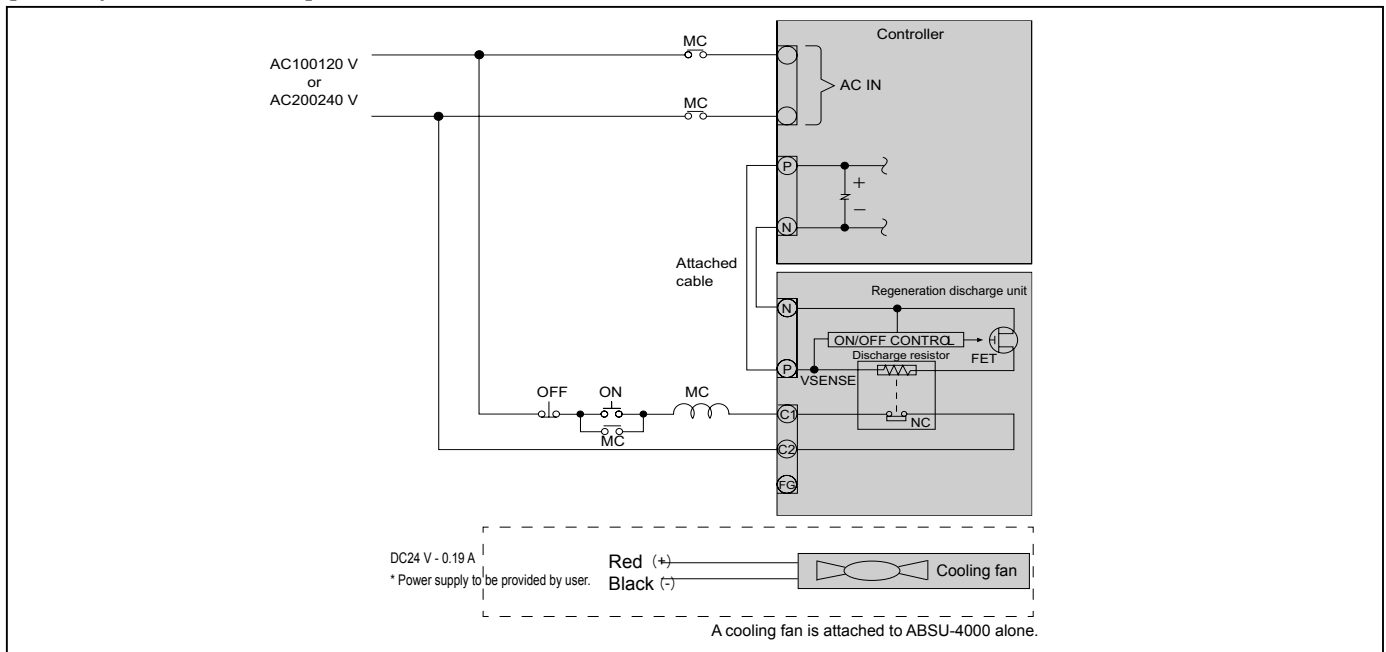

- A thermal relay which operates at the temperature of 150°C is incorporated in the discharge resistor of the regeneration discharge unit.
- When this relay has operated, output terminals C1 to C2 of the regeneration discharge unit is set open.
- Program a sequence so that the controller power is always turned off when the thermal relay has operated.

# Teach Pendant

## [Application]

When the teach pendant is connected with a controller, it can serve as a program and parameter input device, and can give commands for executing motions including home establishment, start, stop, jog motion and emergency stop. The teach pendant also displays and resets an error or fault when it has been generated.

## [Code designation]

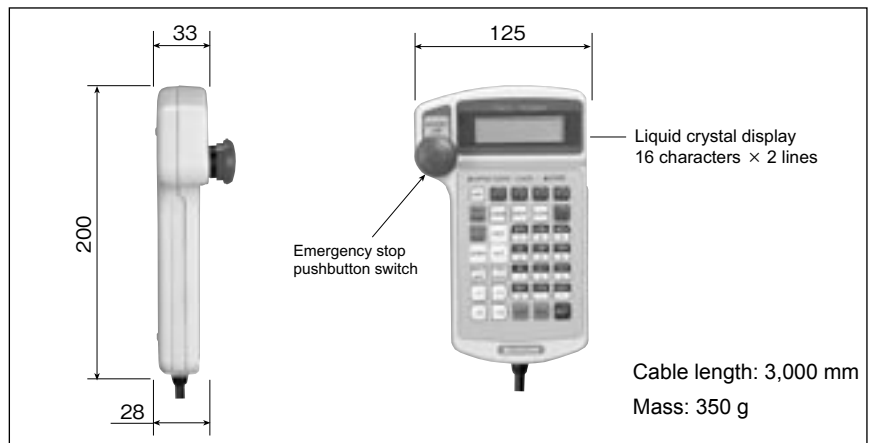
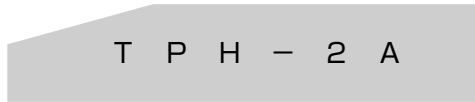

## [Code designation]

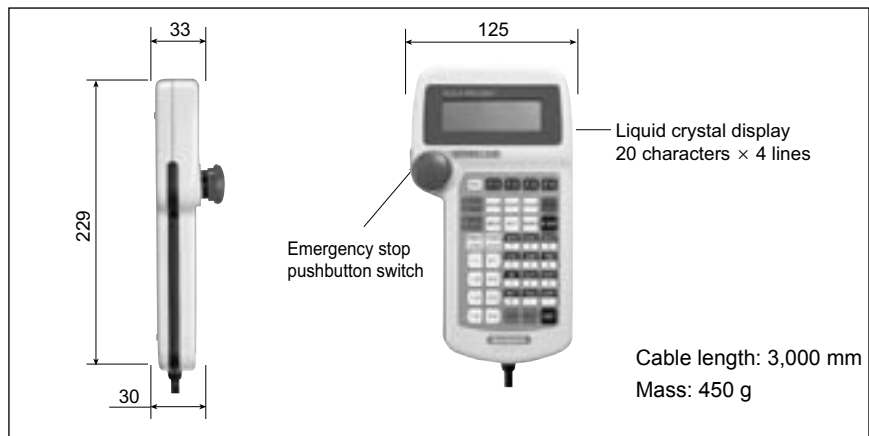
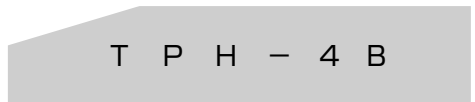

Select either type according to a controller you wish to use.

## Correspondence table of controller and teach pendant

○ -marked : Can be used.

Controller		TPH-2A (Ver2.40 or over) *	TPH-4B (Ver1.30 or over) *
Series	Type		
BA II series carried in this manual	CA 20-M10	○	
	CA 20-M40	○	
	CA 10-M00B		○
	CA 10-M01B		○
Previous BA series	CA 10-M10	○	
	CA 10-M40	○	
	CA 10-M00		○
	CA 10-M01		○

\* The version number can be confirmed in the parameter by connecting the teach pendant with the controller.

## Upgraded ROM

When using the teach pendant of the newest version, the following option ROM is required. The previous version may be used as it is according to the range of use. For details, contact our sales office in your territory.

No	Description	Type	Application
1	TPH-2A upgraded ROM	R - T P 2 - C A	When you already have TPH-2A and wish to upgrade it to the newest version.
2	TPH-4B upgraded ROM	R - T P 4 - C A	When you already have TPH-4B and wish to upgrade it to the newest version.

# Extension I/O Unit

## [Application]

The extension I/O unit can increase the number of general-purpose inputs and outputs when general-purpose inputs and outputs of controllers (master and slave units) alone are not enough.

The number of extension I/O units that can be connected with each controller is one.

The extension I/O unit is connected to the controller directly via a connector on its side. For the number of inputs and outputs, see the specifications.

## [Code designation]

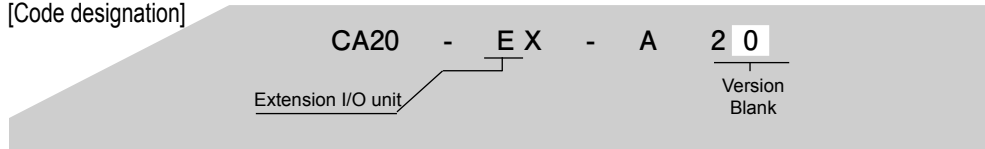

CA20-EX-A20



## [Applicable controller]

CA20-M10, CA20-M40, CA20-S10, CA20-S40

## [Specifications]

Input		Output	
No. of inputs	12 points	No. of outputs	8 points
Input rating	DC24 V, 10 mA/ point	Output signal	Transistor output (open collector)
Insulation	Photo-coupler	Output rating	DC24 V, max. 300 mA/ point
Common	Common to entire 1 circuit	Insulation	Photo-coupler
External connection	Connector (shared with output)	Common	Common to entire 1 circuit

\* Power supply for external devices is not incorporated.

## [Input pin number and signal name]

\* See Page 240 of Technical Notes for I/O connections.

Connector pin arrangement on panel side	No.	I/O	Signal name	No.	I/O	Signal name
<p>(Bottom view)</p>	1		+COM5	14		COM6
	2	Output	General-purpose output port 2-1	15	Input	General-purpose input port 2-1
	3	Output	General-purpose output port 2-2	16	Input	General-purpose input port 2-2
	4	Output	General-purpose output port 2-3	17	Input	General-purpose input port 2-3
	5	Output	General-purpose output port 2-4	18	Input	General-purpose input port 2-4
	6	Output	General-purpose output port 2-5	19	Input	General-purpose input port 2-5
	7	Output	General-purpose output port 2-6	20	Input	General-purpose input port 2-6
	8	Output	General-purpose output port 2-7	21	Input	General-purpose input port 2-7
	9	Output	General-purpose output port 2-8	22	Input	General-purpose input port 2-8
	10		NC	23	Input	General-purpose input port 3-1
	11		NC	24	Input	General-purpose input port 3-2
	12		NC	25	Input	General-purpose input port 3-3
	13		-COM5	26	Input	General-purpose input port 3-4

\* For I/O connection, use an attached plug or separately available I/O cable unit (for extension I/O).

NC: No Connection

## [Dimensions]

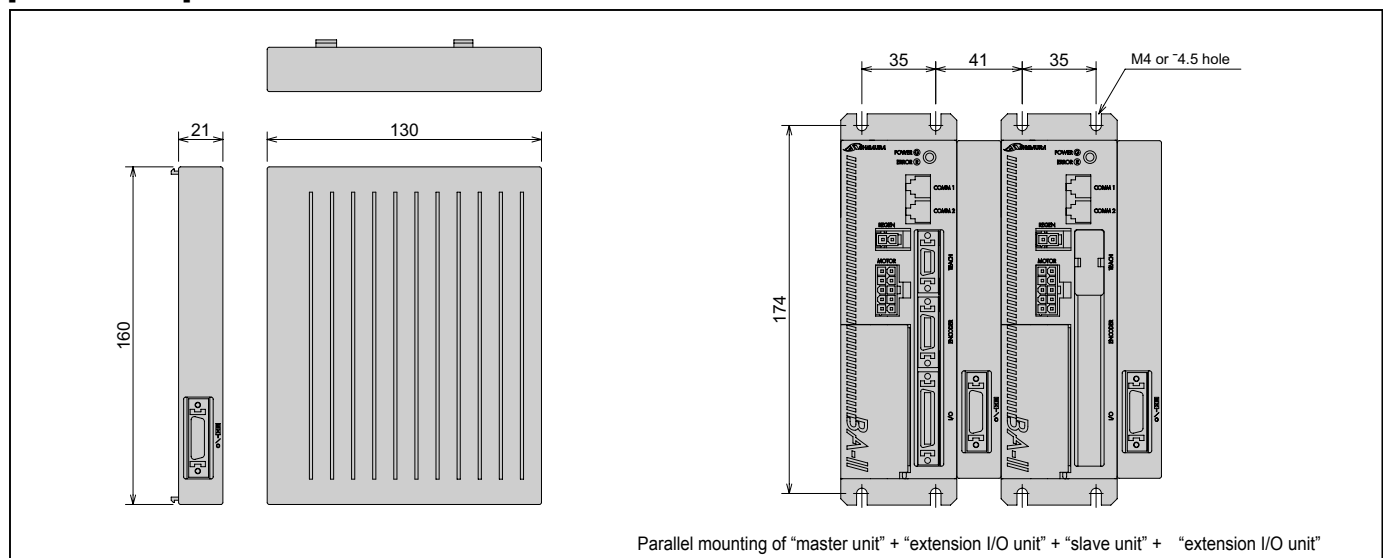

[Code designation]

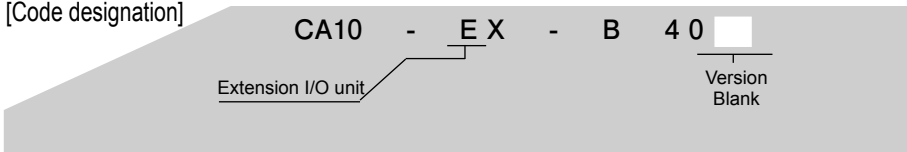

CA10-EX-B40



[Applicable controller]

CA10-M00B, CA10-M01B

[Specifications]

Input		Output	
No. of inputs	24 points	No. of outputs	16 points
Input rating	DC24 V, 10 mA/ point	Output signal	Transistor output (open collector)
Insulation	Photo-coupler	Output rating	DC24 V, max. 300 mA/ point
Common	Common to entire 1 circuit	Insulation	Photo-coupler
External connection	Connector (shared with output)	Common	Common to entire 1 circuit

\* Power supply for external devices is not incorporated.

[Input pin number and signal name]

\* See Page 241 of Technical Notes for I/O connections.

Connector pin arrangement on panel side	No	I/O	Signal	No.	I/O	Signal
<p>(Bottom view)</p>	1		+COM1	26	Input	General-purpose input port 1-1
	2	Output	General-purpose output port 1-1	27	Input	General-purpose input port 1-2
	3	Output	General-purpose output port 1-2	28	Input	General-purpose input port 1-3
	4	Output	General-purpose output port 1-3	29	Input	General-purpose input port 1-4
	5	Output	General-purpose output port 1-4	30	Input	General-purpose input port 1-5
	6	Output	General-purpose output port 1-5	31	Input	General-purpose input port 1-6
	7	Output	General-purpose output port 1-6	32	Input	General-purpose input port 1-7
	8	Output	General-purpose output port 1-7	33	Input	General-purpose input port 1-8
	9	Output	General-purpose output port 1-8	34	Input	General-purpose input port 2-1
	10	Output	General-purpose output port 2-1	35	Input	General-purpose input port 2-2
	11	Output	General-purpose output port 2-2	36	Input	General-purpose input port 2-3
	12	Output	General-purpose output port 2-3	37	Input	General-purpose input port 2-4
	13	Output	General-purpose output port 2-4	38	Input	General-purpose input port 2-5
	14		-COM3	39	Input	General-purpose input port 2-6
	15		-COM3	40	Input	General-purpose input port 2-7
	16		+COM3	41	Input	General-purpose input port 2-8
	17	Output	General-purpose output port 2-5	42	Input	General-purpose input port 3-1
	18	Output	General-purpose output port 2-6	43	Input	General-purpose input port 3-2
	19	Output	General-purpose output port 2-7	44	Input	General-purpose input port 3-3
	20	Output	General-purpose output port 2-8	45	Input	General-purpose input port 3-4
	21	Input	General-purpose input port 3-5	46		Spare
	22	Input	General-purpose input port 3-6	47		Spare
	23	Input	General-purpose input port 3-7	48		Spare
	24	Input	General-purpose input port 3-8	49		Spare
	25		-COM3	50		Spare

\* For I/O connection, use an attached plug or separately available I/O cable unit (for extension I/O).

[Dimensions]

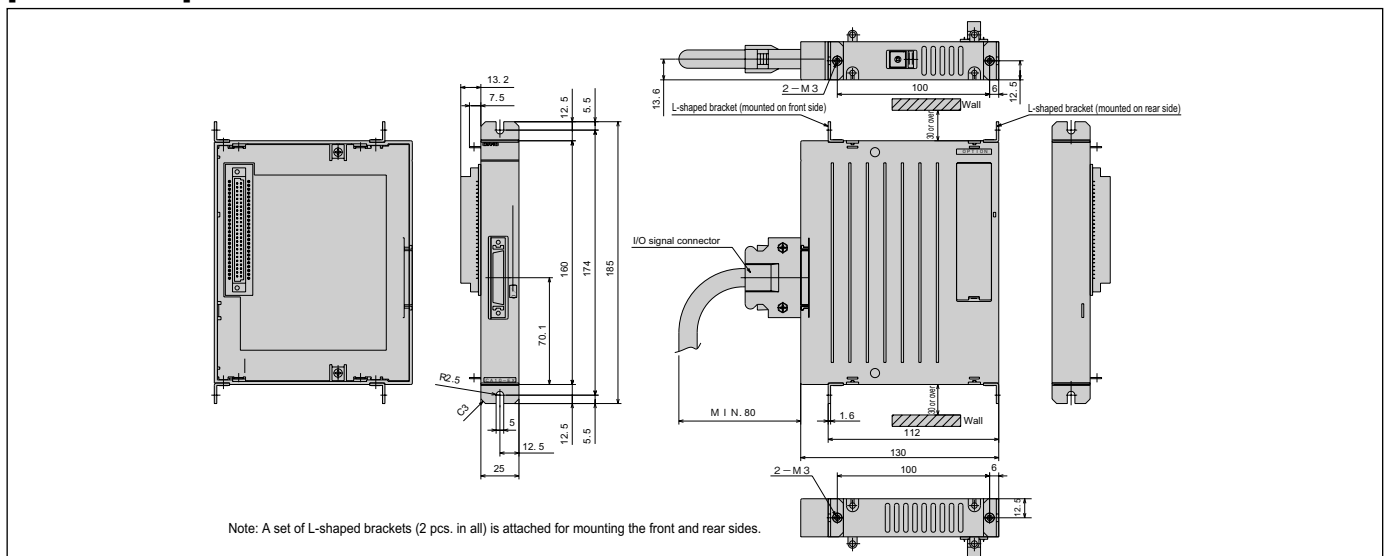

# I/O Cable

## [Application]

Used to connect a controller (master unit, slave unit) or an I/O port of an extension I/O unit to transmit signals with an external operation panel or control device.  
 A plug is attached to one side of the cable, which can be connected directly to the controller.  
 The I/O cable should be connected to an external device according to the color marking put on the cable core leads and the sign table.  
 Before connecting the external device, the cable core leads should be treated with a crimp-terminal.



## [Code designation]

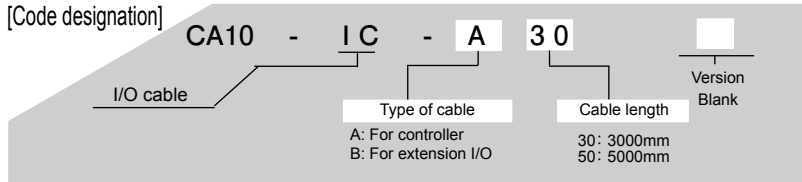

## [Unit connected]

Controller: CA20-M10, CA20-M40,  
 CA20-S10, CA20-S40  
 Extension I/O unit: CA20-EX-A20

\* The I/O cables for controller and extension I/O differ in the number of cable core leads and plug. (For controller: 36-pin, for extension I/O: 26-pin)

## [Dimensions]

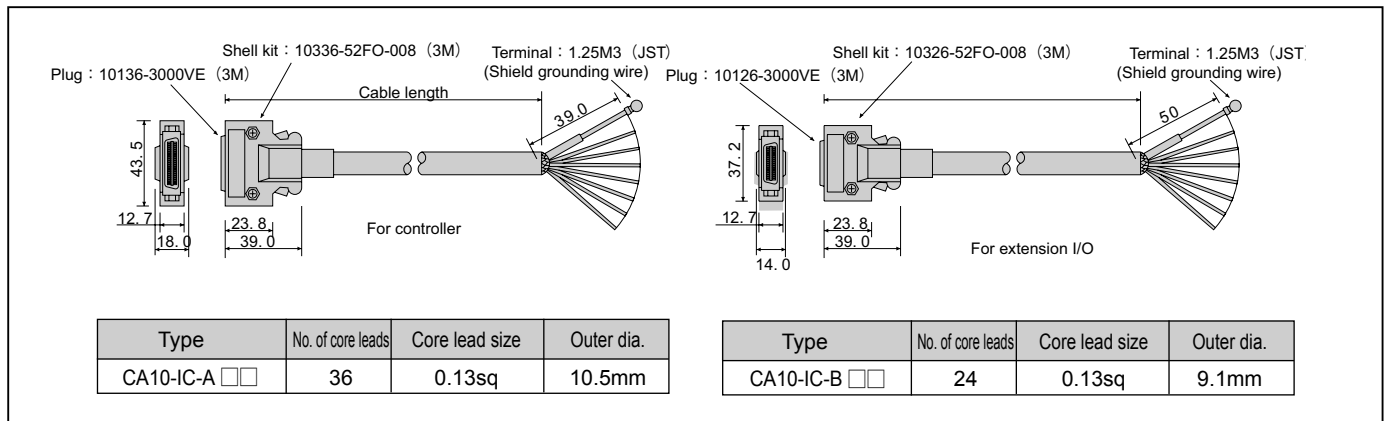

## [Code designation]

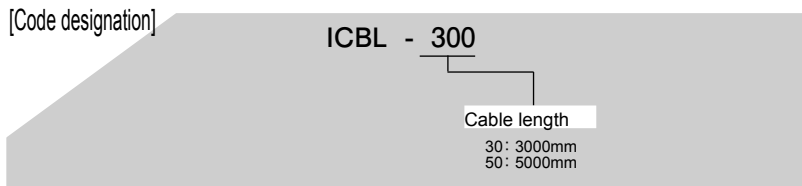

## [Unit connected]

Controller: CA10-M00B, CA10-M01B  
 Extension I/O unit: CA10-EX-B40

## [Dimensions]

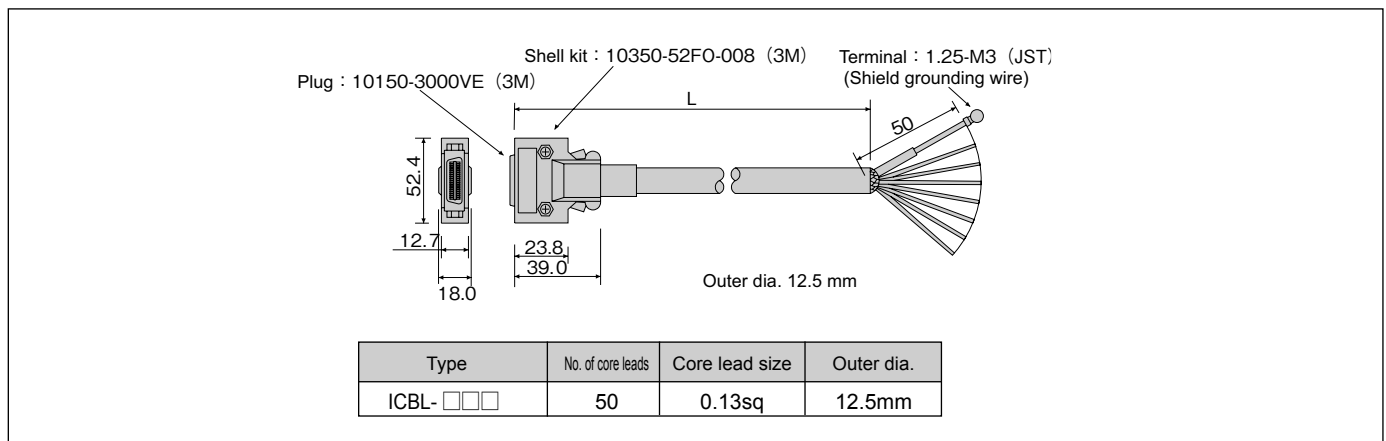

\* The I/O cable is shielded to improve noise resistance. Ground the shield wire as necessary.

\* The I/O cable is not resistant to repeated bending.



# Software for Personal Computer

## [Application]

Software for personal computer SF-98D has been developed to support programming of the ROlbot BAII series by using a personal computer as the host computer.  
 It is possible to transfer program data, etc. of the robot controller to the personal computer and vice versa, edit and save it, to monitor the I/O status and coordinate values and to execute a program, jog motion, home return, etc.  
 This software is optimized for debugging and maintenance.

[Code designation]



[Applicable controller]

All types: CA20-M10, CA20-M40, CA10-M00B and CA10-M01B

## [Specifications]

Contents of package		CD-ROM: 1 pc. Installation manual: 1 copy (Communication cable PCBL-31 is available for an extra price.)
System configuration required	Personal computer	Serial communication port (Din-sub 9-pin) IBM PC/AT compatible computer equipped with CD-ROM drive Available memory size: 12 MB or over Available hard disk size: 10 MB or over
	Operating system (OS)	Japanese version of Microsoft Windows95, Windows98, Windows Me, WindowsNT4.0, Windows2000 and Windows XP
	Display	SVGA or over (resolution 800 × 600 pixel, or over)
	Printer	Printer which can be connected with your personal computer and allows printing from Windows.
	Communication cable	Used to connect the personal computer and controller. Use PCBL-31.
Applicable controller		BA series master unit (CA20-M10, CA20-M40, CA10-M00B, CA10-M01B)

\* Microsoft Windows, Microsoft Windows NT and Windows logotype are the registered trademarks or trademarks of Microsoft Corporation in the United States.

## [Features]

- Programs can be edited easily by using the multi-window screen editor.
- Programs and table data can be sent to and received from the robot controller. Additionally, such data can be saved as a file.
- Axis motions can be controlled by teaching or program execution.
- At printing of a program (i.e., output to the printer), a title and comment can be included. Thus, this software is very convenient for debugging and confirmation of data.

• Editing screen of sequence program



• Editing screen of coordinate table

Data in CSV format as created by using the Excel, etc. can also be input.

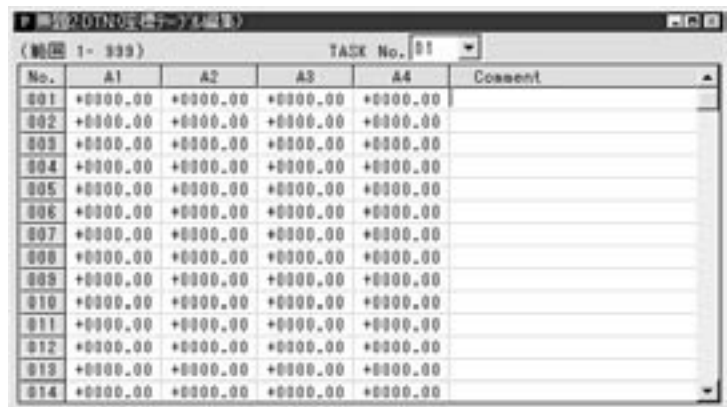

Options

• Robot operation screen

Operations such as program execution and jog motion, which are the same as in the teach pendant, are possible.



• Monitor screen

Current position coordinates, I/O port status can be monitored.

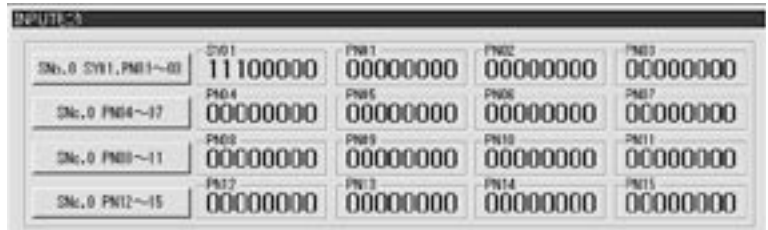

[Connections]

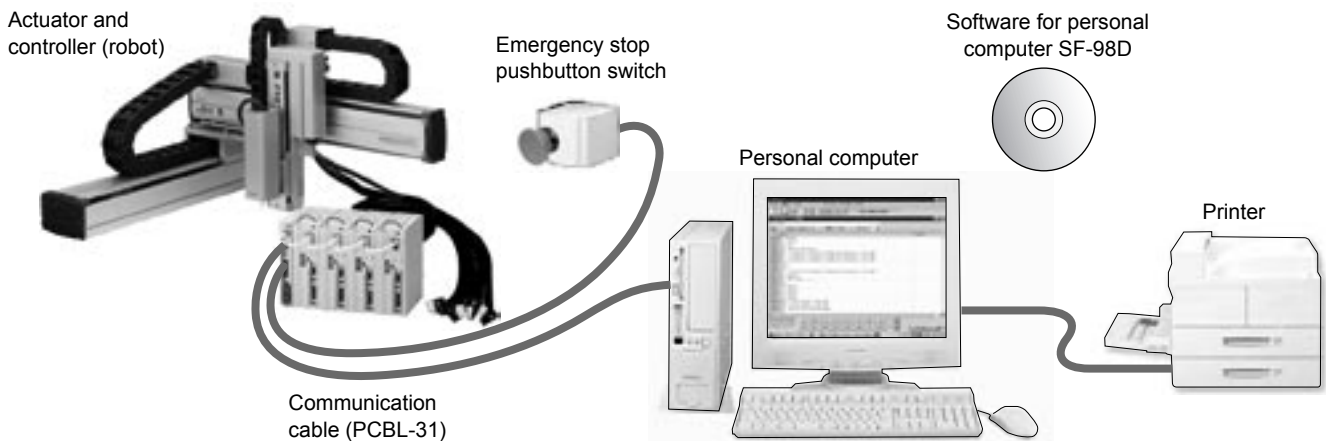

## Communication cable (RS232C)

Options

[Application]

This cable connects the controller and personal computer (IBM/PC compatible). It is used when using the software for personal computer.

[Code designation]

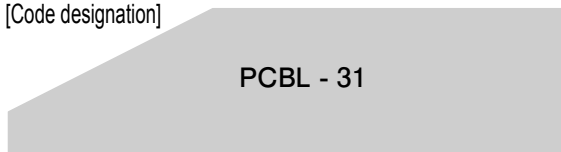

[Dimensions]

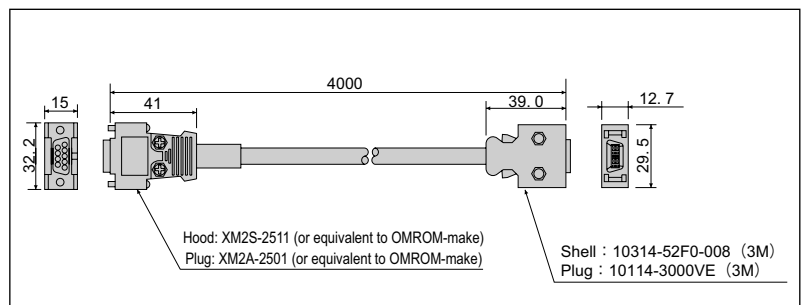

# Memory Card Unit

## [Application]

Used to load (or read) and save (or write) users programs from a memory card. One memory card can save all programs including parameters which are written in the controller. Change of program can be done easily at setup by saving different programs in respective memory cards beforehand.



## [Code designation]

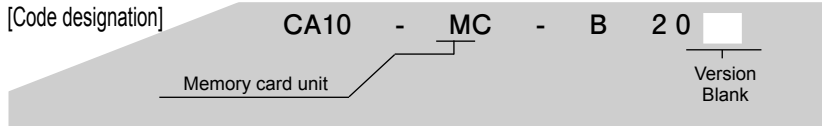

## [Applicable controller]

CA10-M00B, CA10-M01B

\* One memory card is attached to this unit.

## [Dimensions]

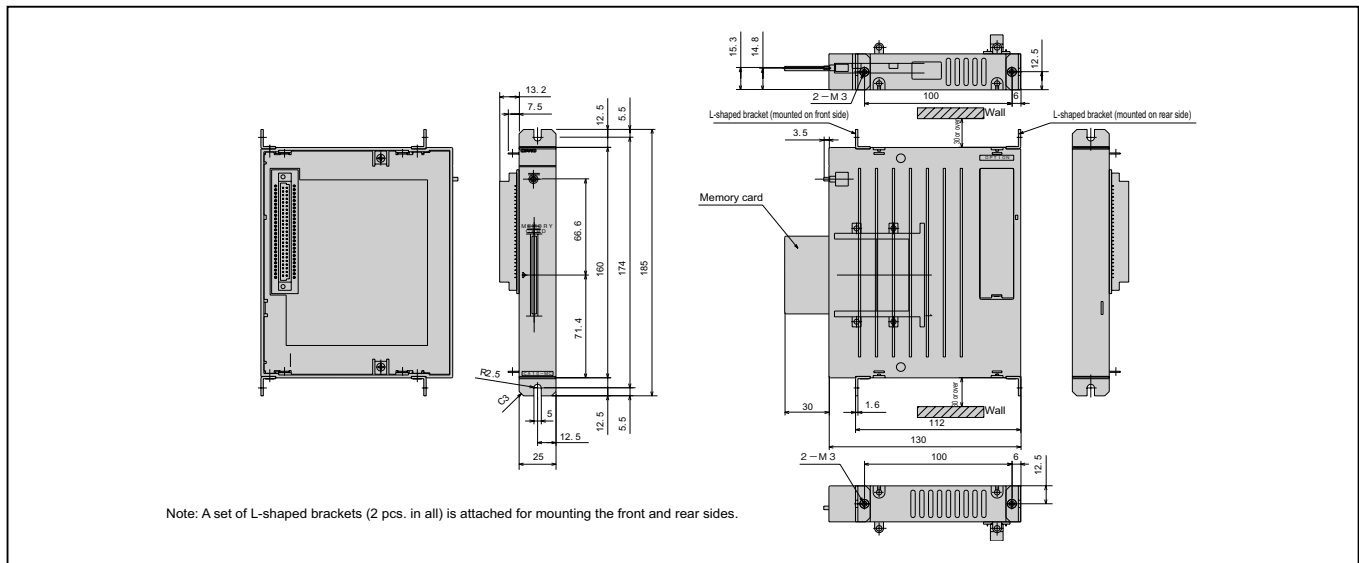

# Lithium Battery for Encoder Backup

## [Application]

Mounted on the controller as a backup battery for an absolute encoder. One each of this battery is attached to master unit CA20-M10/CA20-M40 and slave unit CA20-S10/CA20-S40 as standard. Use this battery for the replacement or spare purpose.

## [Code designation]

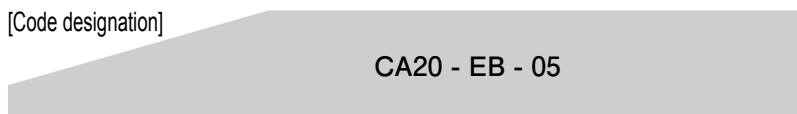

## [Dimensions]

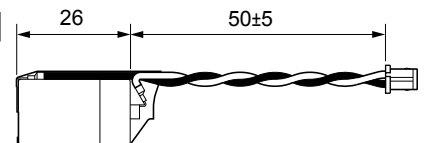

## [Applicable controller]

CA20-M10, CA20-M40, CA20-S10, CA20-S40

## [Specifications]

Item		Description	
Specification	Nominal voltage, Ampere-hour	3.6 V, 1000 mAh	
	Outer dimensions	Battery body	∅ 14.5 × 26 mm (excluding projection)
		Harness length	50±5 mm (excluding connectors)
	Mass	Approx. 10 g	
Backup duration (Note 1)		Approx. 50,000 hours (Note 2)	

Note 1: Total time when the controller power is turned off.

Note 2: Duration of battery varies with the ambient temperature, etc. The figure only provides a yardstick.

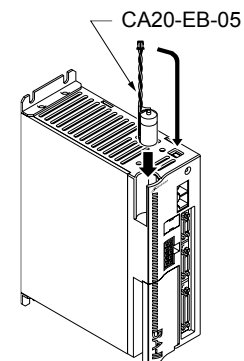

Options



# Technical Notes

## Actuator

Service Life of Guide .....220

Allowable Load Moment

• Allowable Static Load Moment.....220

• Allowable Dynamic Load Moment.....220

## Components of Control System

Operation Mode .....228

Details of Input and Output, and Example Connection

• CA20-M10, CA20-M40 .....231

• CA10-M00B.....235

• CA10-M01B-CC .....237

• CA10-S10.....239

• CA20-EX-A20.....240

• CA10-EX-B40.....241

How to Calculate Tact (Cycle) Time .....242

## Service Life of Guide

Maximum payload and allowable load moment given in this manual are the values calculated based on the following service life of guide.

They are commonly used for both ball-screw driven and timing-belt driven axes of each axis type.

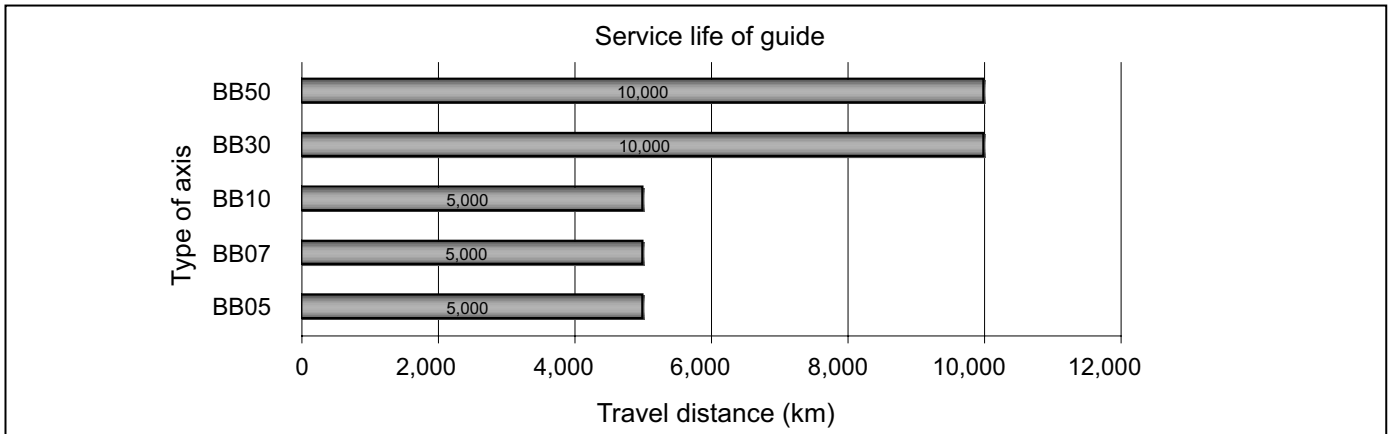

## Allowable Load Moment

As the moment caused by a load imposed on the actuator largely affects the slider bearing unit, the following matters should be considered at use.

- A load exceeding the maximum payload should not be exerted.  
This value can be determined based on the servo motor capacity and differs with the acceleration/deceleration time.
- The moment should not exceed the allowable static load moment.  
This is the moment caused during stop. For the inserting work by using a cylinder attached to the slider, reaction force should be considered. Impact load MUST NOT be exerted.
- The moment should not exceed the allowable dynamic load moment.  
This is the moment caused by acceleration or deceleration.  
The value varies with the load, arm length, direction, etc. Refer to the value given in the table below as a yardstick.

Both allowable static load moment and allowable dynamic load moment are described below. For the maximum payload, see the specifications of each actuator.

### 1. Allowable Static Load Moment

MR: Rolling moment  
MP: Pitching moment  
MY: Yawing moment

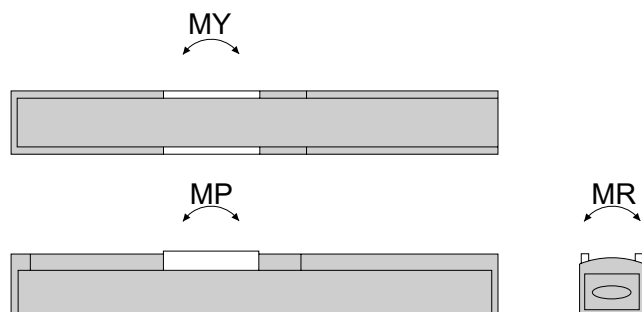

Allowable static load moment N·m	M R					M P					M Y				
	BB05	BB07	BB10	BB30	BB50	BB05	BB07	BB10	BB30	BB50	BB05	BB07	BB10	BB30	BB50
Type of axis															
Short slider (S)	-	-	49	-	-	-	-	14	-	-	-	-	13	-	-
Medium slider (M)	16	32.2	59	510	2080	6.5	8.2	59	430	2160	6	9.9	54	370	1820
Long slider (L)	-	-	-	510	2080	-	-	-	750	3150	-	-	-	650	2640

### 2. Allowable Dynamic Load Moment

Dynamic load moment of an actuator largely influences its life and performance. Allowable dynamic load moment should be calculated, considering the acceleration/deceleration time, (acceleration), load, arm length, direction, speed, stroke, etc., based on the allowable moment of bearing.

Given in the following pages are the tables of allowable dynamic load moment tabulating the load and allowable arm length so that the allowable dynamic load moment can be obtained easily.

Load mass (W kg) and arm length up to the center of gravity of the load (L mm) are shown in each table. (They are not the values of allowable load moment.)

[Table of allowable dynamic load moment] BB05, BB07

Load mass (W kg) and arm length up to the center of gravity of the load (L mm) are shown in each table. (They are not the values of allowable load moment.)

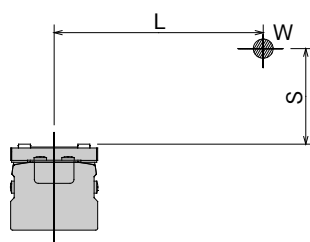

[Mounted horizontally]

BB05	Lead 12												Lead 6								
W [kg]	0.5	1	1.5	2	2.5	3	3.5	4	4.5	5	5.5	6	7	8	9	10	11	12	13	14	15
L [mm]	996	495	328	244	194	160	136	119	103	92	82	74	62	53	45	39	34	30	26	22	19

BB07	Lead 12												Lead 6								
W [kg]	1	2	3	4	5	6	7	8	9	10	11	12	14	16	18	20	22	24	26	28	30
L [mm]	1638	819	546	410	327	273	233	204	181	162	147	135	115	100	88	78	68	60	53	47	42

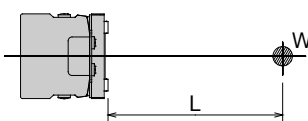

[Mounted horizontally] Wall-mounted

BB05	Lead 12												Lead 6								
W [kg]	0.5	1	1.5	2	2.5	3	3.5	4	4.5	5	5.5	6	7	8	9	10	11	12	13	14	15
L [mm]	1062	529	324	233	178	141	114	95	79	67	57	48	35	25	17	11	6	2	-	-	-

BB07	Lead 12												Lead 6								
W [kg]	1	2	3	4	5	6	7	8	9	10	11	12	14	16	18	20	22	24	26	28	30
L [mm]	1755	852	551	400	310	250	206	174	149	129	112	99	77	61	48	38	29	22	16	11	7

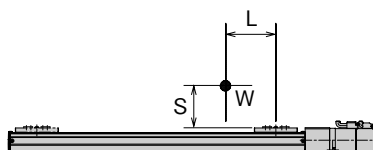

[Mounted horizontally]

BB05	Lead 12												Lead 6								
W [kg]	0.5	1	1.5	2	2.5	3	3.5	4	4.5	5	5.5	6	7	8	9	10	11	12	13	14	15
L [mm]	508	255	171	129	103	86	74	65	57	52	47	43	36	31	27	24	21	18	16	13	12

BB07	Lead 12												Lead 6								
W [kg]	1	2	3	4	5	6	7	8	9	10	11	12	14	16	18	20	22	24	26	28	30
L [mm]	839	423	283	214	173	145	125	110	98	89	81	74	64	57	49	43	38	34	30	27	24

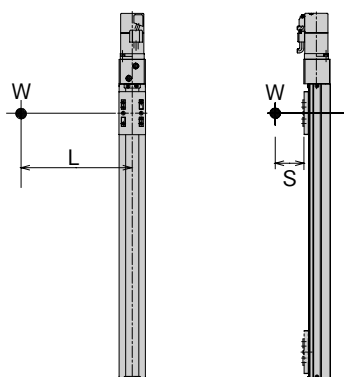

[Mounted vertically]

BB05	Lead 12							Lead 6		
W [kg]	0.5	1	1.5	2	2.5	3	3.5	4		
L [mm]	365	160	92	58	37	23	14	6		

BB07	Lead 12							Lead 6			
W [kg]	1	2	3	4	5	6	7	8			
L [mm]	632	293	181	124	90	68	52	40			

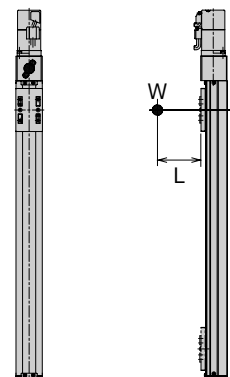

[Mounted vertically]

BB05	Lead 12							Lead 6		
W [kg]	0.5	1	1.5	2	2.5	3	3.5	4		
L [mm]	460	219	138	98	74	58	47	38		

BB07	Lead 12							Lead 6			
W [kg]	1	2	3	4	5	6	7	8			
L [mm]	775	376	243	177	181	110	91	77			

# [Table of allowable dynamic load moment] BB10, BB30, BB50

## Load type I [Mounted horizontally]

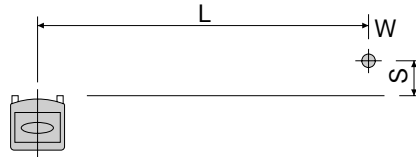

When S = 50 mm:

Arm length up to the center of gravity of load: L

(mm)

Drive system	Actuator	Speed (mm/s)	Lead (mm)	Slider	Load: W																	
					5Kg	10Kg	15Kg	20Kg	25Kg	30Kg	35Kg	40Kg	45Kg	50Kg	55Kg	60Kg	65Kg	70Kg	75Kg	80Kg		
Ball screw	BB10E	1200	20	S	375	175	105	—	—	—	—	—	—	—	—	—	—	—	—	—	—	
				M	700	355	240	—	—	—	—	—	—	—	—	—	—	—	—	—	—	—
		600	10	S	560	270	180	135	110	90	—	—	—	—	—	—	—	—	—	—	—	—
				M	810	395	270	205	167	140	—	—	—	—	—	—	—	—	—	—	—	—
		300	5	S	615	320	210	160	140	110	97	85	77	70	—	—	—	—	—	—	—	—
				M	820	405	275	210	172	145	120	100	87	75	—	—	—	—	—	—	—	—
	BB30E	1200	20	M	1182	590	410	315	—	—	—	—	—	—	—	—	—	—	—	—	—	
				L	1342	670	467	360	—	—	—	—	—	—	—	—	—	—	—	—	—	
		600 (300)	(5)	M	1480	740	515	400	330	285	252	215	185	160	—	—	—	—	—	—	—	
				L	1542	775	537	415	347	300	262	225	192	165	—	—	—	—	—	—	—	
	BB30F	1200	20	M	1135	590	410	315	260	225	200	165	—	—	—	—	—	—	—	—	—	
				L	1290	670	465	360	300	260	230	195	—	—	—	—	—	—	—	—	—	
		600 (300)	(5)	M	1425	740	515	400	330	285	525	215	185	160	140	120	110	95	85	75	—	
				L	1485	775	535	415	345	300	265	225	190	165	145	125	110	100	90	80	—	
	BB50F	1200	20	M	5320	2620	1720	1270	1000	820	690	595	520	460	410	370	—	—	—	—	—	
				L	5545	2730	1795	1325	1040	855	720	620	540	480	430	385	—	—	—	—	—	
		600 (300)	(5)	M	5875	2895	1900	1405	1105	905	765	655	575	510	455	410	370	335	310	285	—	
				L	5945	2925	1920	1420	1115	815	770	665	580	515	460	415	375	340	315	290	—	
	BB50G	1200	20	M	5320	2620	1720	1270	1000	820	690	595	520	460	410	370	335	305	280	255	—	
				L	5545	2730	1795	1325	1040	855	720	620	540	480	430	385	350	320	290	265	—	
		600 (300)	(5)	M	5875	2895	1900	1405	1105	905	765	655	575	510	455	410	370	335	310	285	—	
				L	5945	2925	1920	1420	1115	815	770	665	580	515	460	415	375	340	315	290	—	

★ The speed is applicable when axis stroke is 600 mm or less (acceleration/deceleration time: 0.36 sec).

(mm)

Drive system	Actuator	Speed (mm/s)	Lead (mm)	Slider	Load: W								
					85Kg	90Kg	95Kg	100Kg	110Kg	120Kg	130Kg	140Kg	150Kg
Ball screw	BB50F	600 (300)	(5)	M	260	245	225	210	—	—	—	—	—
				L	270	245	230	210	—	—	—	—	
	BB50G	1200	20	M	235	215	200	185	—	—	—	—	
				L	245	230	210	195	—	—	—	—	
	600 (300)	(5)	M	260	245	225	210	180	160	140	125	110	
			L	270	245	230	210	185	160	140	125	110	

★ The speed is applicable when axis stroke is 600 mm or less (acceleration/deceleration time: 0.36 sec).

Arm length up to the center of gravity of load: L

(mm)

Drive system	Actuator	Speed (mm/s)	Lead (mm)	Slider	Load: W							
					5Kg	10Kg	15Kg	20Kg	25Kg	30Kg	35Kg	40Kg
Timing belt	BB10E	1000	21	S	375	175	105	—	—	—	—	—
				M	700	355	240	—	—	—	—	—
	BB10F	1000	21	S	375	175	105	70	—	—	—	—
				M	700	355	240	180	—	—	—	—
	2000	42	S	112	52	—	—	—	—	—	—	
			M	210	106	—	—	—	—	—	—	
	BB30E	1000	21	M	1182	590	410	—	—	—	—	—
				L	1342	670	467	—	—	—	—	—
	BB30F	1000	21	M	1135	590	410	315	260	225	200	165
				L	1290	670	465	360	300	260	230	195
		2000	42	M	454	236	164	126	—	—	—	—
				L	516	268	186	144	—	—	—	—
	BB50F	1000	21	M	5320	2620	1720	1270	1000	850	690	595
				L	5545	2730	1795	1325	1040	855	720	620
	BB50G	2000	42	M	2128	1048	688	508	—	—	—	—
				L	2218	1092	718	530	—	—	—	—

★ The speed is applicable when the lead is 21 mm and acceleration/deceleration time is 0.3 sec, and when the lead is 42 mm and acceleration/deceleration time is 0.5 sec.



[Table of allowable dynamic load moment] BB10, BB30, BB50

When S = 200 mm:

Arm length up to the center of gravity of load: L

(mm)

Drive system	Actuator	Speed (mm/s)	Lead (mm)	Slider	Load: W																
					5Kg	10Kg	15Kg	20Kg	25Kg	30Kg	35Kg	40Kg	45Kg	50Kg	55Kg	60Kg	65Kg	70Kg	75Kg	80Kg	
Ball screw	BB10E	1200	20	S	310	105	—	—	—	—	—	—	—	—	—	—	—	—	—	—	
				M	690	340	220	—	—	—	—	—	—	—	—	—	—	—	—	—	—
		600	10	S	537	245	150	105	75	50	—	—	—	—	—	—	—	—	—	—	—
				M	790	390	265	200	165	135	—	—	—	—	—	—	—	—	—	—	—
		300	5	S	622	300	200	150	120	100	87	75	67	60	—	—	—	—	—	—	—
				M	820	405	275	210	172	145	120	100	87	75	—	—	—	—	—	—	—
	BB30E	1200	20	M	1180	585	400	305	—	—	—	—	—	—	—	—	—	—	—	—	
				L	1342	670	462	355	—	—	—	—	—	—	—	—	—	—	—	—	
		600 (300)	10 (5)	M	1480	740	515	395	330	280	250	215	180	155	—	—	—	—	—	—	
				L	1542	770	537	415	345	295	262	225	190	165	—	—	—	—	—	—	
	BB30F	1200	20	M	1135	585	400	305	225	185	155	130	—	—	—	—	—	—	—	—	
				L	1290	670	460	355	295	250	220	190	—	—	—	—	—	—	—	—	
		600 (300)	10 (5)	M	1425	740	510	395	330	280	250	215	180	155	135	120	105	90	80	70	
				L	1485	770	535	415	345	295	365	225	190	165	145	125	110	100	85	45	
	BB50F	1200	20	M	5320	2620	1720	1265	995	815	685	590	515	450	400	360	—	—	—	—	
				L	5545	2730	1790	1325	1040	855	720	615	540	475	425	380	—	—	—	—	
		600 (300)	10 (5)	M	5875	2895	1900	1400	1105	905	765	655	575	505	455	405	370	335	310	285	
				L	5945	2925	1920	1420	1115	915	770	665	580	515	460	415	375	340	310	285	
	BB50G	1200	20	M	5320	2620	1720	1265	995	815	685	590	515	450	400	360	325	295	270	245	
				L	5545	2730	1790	1325	1040	855	720	615	540	475	425	380	345	315	285	260	
		600 (300)	10 (5)	M	5785	2895	1900	1400	1105	905	765	655	575	505	455	405	370	335	310	285	
				L	5945	2925	1920	1420	1115	915	770	665	580	515	460	415	375	340	310	285	

★ The speed is applicable when axis stroke is 600 mm or less (acceleration/deceleration time: 0.36 sec).

(mm)

Drive system	Actuator	Speed (mm/s)	Lead (mm)	Slider	Load: W									
					85Kg	90Kg	95Kg	100Kg	110Kg	120Kg	130Kg	140Kg	150Kg	
Ball screw	BB50F	600 (300)	10 (5)	M	260	240	225	210	—	—	—	—	—	—
				L	265	245	225	210	—	—	—	—	—	
	BB50G	1200	20	M	225	205	190	175	—	—	—	—	—	
				L	240	220	205	190	—	—	—	—	—	
	600 (300)	10 (5)	M	260	240	225	210	180	160	140	120	105		
			L	265	245	225	210	185	160	140	125	110		

★ The speed is applicable when axis stroke is 600 mm or less (acceleration/deceleration time: 0.36 sec).

Arm length up to the center of gravity of load: L

(mm)

Drive system	Actuator	Speed (mm/s)	Lead (mm)	Slider	Load: W								
					5Kg	10Kg	15Kg	20Kg	25Kg	30Kg	35Kg	40Kg	
Timing belt	BB10E	1000	21	S	310	105	—	—	—	—	—	—	—
				M	690	340	220	—	—	—	—	—	
	BB10F	1000	21	S	310	105	—	—	—	—	—	—	—
				M	690	340	220	160	—	—	—	—	
	2000	42	S	93	31	—	—	—	—	—	—	—	
			M	207	102	66	48	—	—	—	—		
	BB30E	1000	21	M	1180	585	400	—	—	—	—	—	
				L	1342	670	462	—	—	—	—	—	
	BB30F	1000	21	M	1135	585	400	305	225	185	155	130	
				L	1290	670	460	355	295	250	220	190	
		2000	42	M	454	454	454	454	—	—	—	—	
				L	516	268	184	142	—	—	—	—	
	BB50F	1000	21	M	5320	2620	1720	1265	995	815	685	590	
				L	5545	2730	1790	1325	1040	855	720	615	
	BB50G	2000	42	M	2128	1048	688	506	—	—	—	—	
				L	2218	1092	716	530	—	—	—	—	

★ The speed is applicable when the lead is 21 mm and acceleration/deceleration time is 0.3 sec, and when the lead is 42 mm and acceleration/deceleration time is 0.5 sec.

Actuator

# [Table of allowable dynamic load moment] BB10, BB30, BB50

Load type II [Mounted horizontally]  
Wall-mounted

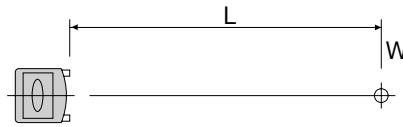

Arm length up to the center of gravity of load: L

(mm)

Drive system	Actuator	Speed (mm/s)	Lead (mm)	Slider	Load: W																
					5Kg	10Kg	15Kg	20Kg	25Kg	30Kg	35Kg	40Kg	45Kg	50Kg	55Kg	60Kg	65Kg	70Kg	75Kg	80Kg	
Ball screw	BB10E	1200	20	S	335	130	60	—	—	—	—	—	—	—	—	—	—	—	—	—	
				M	660	290	165	—	—	—	—	—	—	—	—	—	—	—	—	—	—
		600	10	S	440	165	85	40	12	—	—	—	—	—	—	—	—	—	—	—	—
				M	715	310	175	110	72	45	—	—	—	—	—	—	—	—	—	—	—
		300	5	S	467	180	90	45	17	0	—	—	—	—	—	—	—	—	—	—	—
				M	720	305	175	110	72	45	27	15	3	—	—	—	—	—	—	—	—
	BB30E	1200	20	M	1342	610	388	275	—	—	—	—	—	—	—	—	—	—	—	—	
				L	1435	855	413	2990	—	—	—	—	—	—	—	—	—	—	—	—	
		600 (300)	10 (5)	M	1467	670	423	300	228	175	140	115	95	80	—	—	—	—	—	—	
				L	1482	675	428	300	228	180	143	115	95	80	—	—	—	—	—	—	
		1200	20	M	1285	610	385	275	205	160	130	105	—	—	—	—	—	—	—	—	
				L	1375	655	410	290	220	170	135	110	—	—	—	—	—	—	—	—	
	600 (300)	10 (5)	M	1405	670	420	300	225	175	140	115	95	80	65	55	45	35	30	20		
			L	1420	675	425	300	230	180	140	115	95	80	65	55	45	35	30	25		
	BB50F	1200	20	M	5690	2815	1855	1375	1085	895	760	655	575	510	460	145	—	—	—	—	
				L	5900	2915	1920	1425	1125	930	785	680	595	530	475	430	—	—	—	—	
		600 (300)	10 (5)	M	6055	2995	1975	1460	1155	850	805	695	610	545	490	440	405	370	340	315	
				L	6085	3010	1985	1470	1165	955	810	700	615	545	490	445	405	370	340	315	
		1200	20	M	5690	2815	1855	1375	1085	895	760	655	575	510	460	415	375	345	320	295	
				L	5900	2915	1920	1425	1125	930	785	680	595	530	475	430	390	360	330	305	
	600 (300)	10 (5)	M	6055	2995	1975	1460	1155	850	805	695	610	545	490	440	405	370	340	315		
			L	6085	3010	1985	1470	1165	955	810	700	615	545	490	445	405	370	340	315		

★ The speed is applicable when axis stroke is 600 mm or less (acceleration/deceleration time: 0.36 sec).

(mm)

Drive system	Actuator	Speed (mm/s)	Lead (mm)	Slider	Load: W								
					85Kg	90Kg	95Kg	100Kg	110Kg	120Kg	130Kg	140Kg	150Kg
Ball screw	BB50F	600 (300)	10 (5)	M	290	272	255	240	—	—	—	—	—
				L	295	275	255	240	—	—	—	—	
	BB50G	1200	20	M	275	255	240	220	—	—	—	—	
				L	285	265	245	230	—	—	—	—	
	600 (300)	10 (5)	M	290	270	255	240	210	185	170	150	135	
			L	295	275	255	240	210	190	170	150	135	

★ The speed is applicable when axis stroke is 600 mm or less (acceleration/deceleration time: 0.36 sec).

Arm length up to the center of gravity of load: L

(mm)

Drive system	Actuator	Speed (mm/s)	Lead (mm)	Slider	Load: W							
					5Kg	10Kg	15Kg	20Kg	25Kg	30Kg	35Kg	40Kg
Timing belt	BB10E	1000	21	S	335	130	60	—	—	—	—	—
				M	660	290	165	—	—	—	—	
	BB10F	1000	21	S	335	130	60	35	—	—	—	—
				M	660	290	165	105	—	—	—	
	2000	42	S	100	39	—	—	—	—	—		
			M	198	87	—	—	—	—	—		
	BB30E	1000	21	M	1342	610	388	—	—	—	—	
				L	1435	655	413	—	—	—	—	
	BB30F	1000	21	M	1285	610	385	275	205	160	130	105
				L	1375	655	410	290	220	170	135	110
	2000	42	M	514	244	154	110	—	—	—	—	
			L	550	262	164	116	—	—	—	—	
	BB50F	1000	21	M	5690	2815	1855	1375	1085	895	760	655
				L	5900	2915	1920	1425	1125	930	785	680
	BB50G	2000	42	M	2276	1126	742	550	—	—	—	—
				L	2360	1166	768	570	—	—	—	—

★ The speed is applicable when the lead is 21 mm and acceleration/deceleration time is 0.3 sec, and when the lead is 42 mm and acceleration/deceleration time is 0.5 sec.

[Table of allowable dynamic load moment] BB10, BB30, BB50

Load type III [Mounted horizontally]

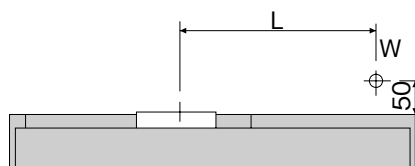

Arm length up to the center of gravity of load: L (mm)

Drive system	Actuator	Speed (mm/s)	Lead (mm)	Slider	Load: W																
					5Kg	10Kg	15Kg	20Kg	25Kg	30Kg	35Kg	40Kg	45Kg	50Kg	55Kg	60Kg	65Kg	70Kg	75Kg	80Kg	
Ball screw	BB10E	1200	20	S	215	105	70	50	—	—	—	—	—	—	—	—	—	—	—	—	
				M	900	415	265	210	—	—	—	—	—	—	—	—	—	—	—	—	—
		600	10	S	215	105	80	55	47	40	—	—	—	—	—	—	—	—	—	—	—
				M	837	425	265	195	153	120	—	—	—	—	—	—	—	—	—	—	—
		300	5	S	240	120	80	65	52	40	35	30	30	25	—	—	—	—	—	—	—
				M	915	465	295	205	153	120	100	85	72	65	—	—	—	—	—	—	—
	BB30E	1200	20	M	1380	690	480	370	—	—	—	—	—	—	—	—	—	—	—	—	
				L	2400	1200	835	650	—	—	—	—	—	—	—	—	—	—	—	—	
		600 (300)	10 (5)	M	1290	690	483	375	310	265	235	200	170	150	—	—	—	—	—	—	
				L	2400	1205	838	650	540	465	410	350	300	260	—	—	—	—	—	—	
	BB30F	1200	20	M	1330	690	480	370	305	265	235	200	—	—	—	—	—	—	—	—	
				L	2305	1200	835	650	540	465	410	350	—	—	—	—	—	—	—	—	
		600 (300)	10 (5)	M	1300	690	480	375	310	265	235	200	170	150	130	115	100	90	80	70	
				L	2310	1205	835	650	540	465	415	350	300	260	225	200	175	155	140	125	
	BB50F	1200	20	M	6380	3140	2060	1520	1200	980	930	710	620	550	490	440	—	—	—	—	
				L	9280	4570	3000	2215	1745	1430	1205	1040	905	800	715	645	—	—	—	—	
		600 (300)	10 (5)	M	6380	3140	2060	1125	1200	985	830	715	625	550	495	445	400	365	335	310	
				L	9280	4570	3000	2215	1745	1430	1205	1040	910	805	720	645	585	535	490	450	
	BB50G	1200	20	M	6380	3140	2060	1520	1200	980	830	710	620	550	490	440	400	365	335	305	
				L	9280	4570	3000	2215	1745	1430	1205	1040	905	800	715	645	585	55	490	450	
		600 (300)	10 (5)	M	6380	3140	2060	1125	1200	985	830	715	625	550	495	445	400	365	335	310	
				L	9280	4570	3000	2215	1745	1430	1205	1040	910	805	720	645	585	535	490	450	

★ The speed is applicable when axis stroke is 600 mm or less (acceleration/deceleration time: 0.36 sec).

(mm)

Drive system	Actuator	Speed (mm/s)	Lead (mm)	Slider	Load: W									
					85Kg	90Kg	95Kg	100Kg	110Kg	120Kg	130Kg	140Kg	150Kg	
Ball screw	BB50F	600 (300)	10 (5)	M	285	265	245	230	—	—	—	—	—	—
				L	415	385	355	330	—	—	—	—	—	
	BB50G	1200	20	M	280	260	240	225	—	—	—	—	—	
				L	415	385	355	330	—	—	—	—	—	
	600 (300)	10 (5)	M	285	265	245	230	200	175	155	135	120		
			L	415	385	355	330	290	255	225	200	175		

★ The speed is applicable when axis stroke is 600 mm or less (acceleration/deceleration time: 0.36 sec).

Arm length up to the center of gravity of load: L (mm)

Drive system	Actuator	Speed (mm/s)	Lead (mm)	Slider	Load: W							
					5Kg	10Kg	15Kg	20Kg	25Kg	30Kg	35Kg	40Kg
Timing belt	BB10E	1000	21	S	215	105	70	—	—	—	—	—
				M	900	415	265	—	—	—	—	—
	BB10F	1000	21	S	215	105	70	50	—	—	—	—
				M	900	415	265	210	—	—	—	—
	2000	42	S	64	31	—	—	—	—	—	—	
			M	270	124	—	—	—	—	—	—	
	BB30E	1000	21	M	1380	690	480	—	—	—	—	—
				L	2400	1200	835	—	—	—	—	—
	BB30F	1000	21	M	1330	690	480	370	305	265	235	200
				L	2305	1200	835	650	540	465	410	350
		2000	42	M	532	276	192	148	—	—	—	—
				L	922	480	334	260	—	—	—	—
	BB50F	1000	21	M	6380	3140	2060	1520	1200	980	830	710
				L	9280	4570	3000	2215	1745	1430	1205	1040
	BB50G	2000	42	M	2552	1256	824	608	—	—	—	—
				L	3712	1828	1200	886	—	—	—	—

★ The speed is applicable when the lead is 21 mm and acceleration/deceleration time is 0.3 sec, and when the lead is 42 mm and acceleration/deceleration time is 0.5 sec.



[Table of allowable dynamic load moment] BB10, BB30, BB50

Load type V [Mounted vertically]

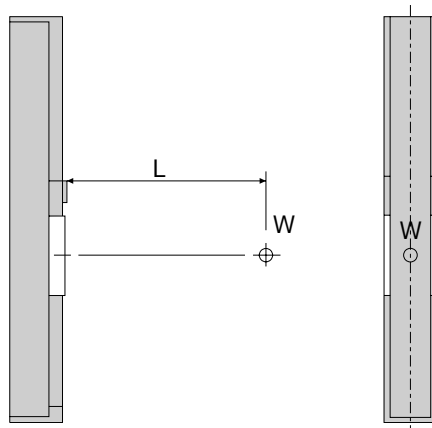

Arm length up to the center of gravity of load: L

(mm)

Drive system	Actuator	Speed (mm/s)	Lead (mm)	Slider	Load: W																		
					3Kg	5Kg	8Kg	10Kg	12Kg	14Kg	16Kg	18Kg	20Kg	22Kg	25Kg	30Kg	35Kg	40Kg	45Kg	50Kg	55Kg	60Kg	
Ball screw	BB10E	1200	20	S	295	160	—	—	—	—	—	—	—	—	—	—	—	—	—	—	—	—	
				M	1325	780	—	—	—	—	—	—	—	—	—	—	—	—	—	—	—	—	—
		600	10	S	355	190	95	70	50	—	—	—	—	—	—	—	—	—	—	—	—	—	—
				M	1405	830	510	510	400	330	—	—	—	—	—	—	—	—	—	—	—	—	—
		300	5	S	390	210	110	75	50	40	30	25	20	15	—	—	—	—	—	—	—	—	—
				M	1420	835	510	400	330	280	240	210	185	165	—	—	—	—	—	—	—	—	—
	BB30E	1200	20	M	1925	1140	—	—	—	—	—	—	—	—	—	—	—	—	—	—	—	—	
				L	3370	2005	—	—	—	—	—	—	—	—	—	—	—	—	—	—	—	—	
		600	10	M	2060	1220	750	590	485	—	—	—	—	—	—	—	—	—	—	—	—	—	
				L	3605	2150	1330	1055	870	—	—	—	—	—	—	—	—	—	—	—	—	—	
		300	5	M	2080	1235	755	595	490	415	360	315	280	250	—	—	—	—	—	—	—	—	
				L	3640	2170	1340	1070	880	750	650	575	515	465	—	—	—	—	—	—	—	—	
	BB30F	1200	20	M	2173	1190	700	550	—	—	—	—	—	—	—	—	—	—	—	—	—		
				L	3798	2092	1240	985	—	—	—	—	—	—	—	—	—	—	—	—	—		
		600	10	M	2323	1272	750	590	485	410	355	310	275	—	—	—	—	—	—	—			
				L	4198	2375	1330	1055	870	74	645	570	510	—	—	—	—	—	—	—			
		300	5	M	2345	1285	755	595	490	415	360	315	280	250	215	175	145	120	—	—			
				L	4100	2260	1340	1070	880	750	650	575	515	465	402	330	277	235	—	—			
	BB50F	1200	20	M	11173	6197	3700	2950	2450	—	—	—	—	—	—	—	—	—	—	—			
				L	16300	9035	5400	4310	3585	—	—	—	—	—	—	—	—	—	—	—			
		600	10	M	11963	6625	3955	3155	2620	2240	1955	1730	1555	1410	1235	—	—	—	—	—			
				L	17423	9657	5775	4610	3835	3280	2865	2540	2280	2070	1815	—	—	—	—	—			
		300	5	M	12075	6732	9559	3185	2645	2260	1975	1750	1570	1420	1245	1030	877	760	670	600	—		
				L	17588	9750	5830	4655	3870	3310	2890	2565	2305	2090	1835	1520	1297	1130	997	895	—		
BB50G	1200	20	M	11193	6197	3700	2950	2450	2095	1825	1620	1450	1315	1150	—	—	—	—	—				
			L	16300	9035	5400	4310	3585	3065	2675	2375	2130	1935	1695	—	—	—	—	—				
	600	10	M	11963	6625	3955	3155	2620	2240	1955	1730	1555	1410	1235	1020	867	755	665	595	—			
			L	17423	9657	5775	4610	3835	3280	2865	2540	2280	2070	1815	1505	1285	1115	987	885	—			
	300	5	M	12075	6735	3995	3185	2645	2260	1975	1750	1570	1420	1245	1030	877	760	670	600	540	490		
			L	17588	9750	5830	4655	3870	3310	2890	2565	2305	2090	1835	1520	1297	1130	997	895	805	735		

★ The speed is applicable when axis stroke is 600 mm or less (acceleration/deceleration time: 0.36 sec).

# Operation Mode

## [Sequential mode]

Mode in which a program created, using instruction words, is executed in the order of steps.

Type of master unit	CA20-M10, CA20-M40	CA10-M00B, CA10-M01B
No. of program steps	2,000 steps (Note 1)	2,500 steps (Note 1)
Coordinate table	999 points × 4 tasks	999 points × 1 task
Speed setting	10 steps (variable)	10 steps (variable)
Acceleration/deceleration setting	20 steps (variable)	20 steps (variable)
No. of counters	99	99
No. of timers	9	9
Multitask	Maximum number. of tasks	4 tasks
	Maximum number of controlled axes	4 axes
	Maximum number of controlled axes per task	2 axes
		4 tasks (For axis motion, only one task can be used.)
		4 axes
		4 axes

Note 1: Total number of steps of 4 tasks. In the easy mode, the maximum number of steps is 1,000.

### Example programming in sequential mode

[Motion]  
When general-purpose input port 1-3 is ON after the axes reach point B via point A from the origin, they move to point C (good product). When it is OFF, they move to point D (rejected product).

	X	Y
Coordinates of point A	(100,	0)
Coordinates of point B	(200,	200)
Coordinates of point C	(200,	300)
Coordinates of point D	(300,	200)

[Example of using general-purpose input signals]  
Signal for good product: Port 1-3 ON  
Signal for rejected product: Port 1-3 OFF  
For input signal timing: Use of port 1-8

Flow chart	Example program			
	Step	Command	Data	Comment
	0001	SPD	V=05	
	0002	MOV	a S V=00 X=100 POST Y=0	Point (A)
	0003	MOV	a S V=00 X=200 POST Y=200	Point (B)
	0004	IN	PORT [1] 1 . . . . .	Waiting for input of good or rejected product judgment signal.
	0005	JMPI	10 PORT [1] . . . . . 1 . . .	When general-purpose input port 1-3 is ON, jump to tag No. 10.
	0006	MOV	a S V=00 X=300 POST Y=200	Point (D) (when rejected product judgment signal has reached)
	0007	END		
	0008	TAG	10	
	0009	MOV	a S V=00 X=200 POST Y=300	Point (C) (when good product judgment signal has reached)
	0010	END		

Note: The CA20-M10 (40) controller uses MOV P command in lieu of MOV command.

[Input timing of general-purpose input signals]  
After the good product or rejected product judgment signal (general-purpose input port 1-3) is ON, the timing signal (general-purpose input port 1-8) is input.

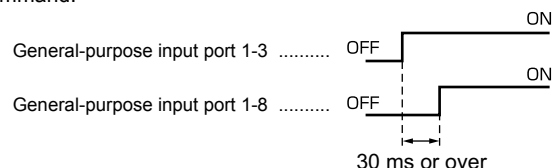

List of commands (instruction words) for sequential mode

Controller: CA20-M10, CA20-M40  
Teach pendant: TPH-2A

Command	Description
Command for axis movement	
MOV	Execution of move data value in specified coordinate table.
MVB	Return from current position to just preceding teaching position.
MVE	Escape movement
HOME	Home return command
Command for parameter setting	
SPD	Speed setting
ACC	Acceleration/deceleration setting
OFS	Offset setting
Command for I/O port control	
OUT	Output to general-purpose port.
OUTP	Pulse output to general-purpose port.
OUTC	Counter value output to general-purpose port.
IN	Waiting for input.
INPC	Setting of input status of general-purpose port to counter.
Command for timer/counter control	
TIM	Waiting for time.
TIMP	Preset of timer number and time.
CNT	Preset of counter number and count value.
CNT+	Addition of counter value.
CNT-	Subtraction of counter value.
CNTC	Clear of all counters.
Command for program control	
NOP	Non-operation
RET	Return (declaration of ending a subroutine).
STOP	Stop
END	Program end
TAG	Jump to a tag (destination label)
PSEL	Program selection
Command for servo control	
SVON	Servo ON
SVOF	Servo OFF
Command for matrix operation	
MVM	Matrix movement
LOOP	MVM loop
MINI	Initialization of MVM counter.
Command for jump	
JMP	Unconditional jump.
JMPI	Jump with input condition.
JMPC	Jump with counter condition.
JMPT	Jump with timer condition.
BRAC	Jump to a tag of counter value.
Command for subroutine call	
CAL	Unconditional call (unconditional jump to specified subroutine).
CALI	Call with input condition (call of specified subroutine with input condition).
CALC	Call with counter condition.
CALT	Call with timer condition.
Command for task control	
TSTR	Task start
TSTO	Temporary stop of task.
TRSA	Task restart
TCAN	Compulsive finish of task.

Controller: CA10-M00B, CA10-M01B  
Teach pendant: TPH-4B

Command	Description
Command for axis movement	
MOV	Axis travel
MOV	Axis travel (coordinate table indirect)
MVC	Circular interpolation
MVCP	Circular interpolation (coordinate table indirect)
MVB	Move to just preceding position (return to just preceding position).
MVE	Escape movement
RSMV	Axis travel via RS232C.
HOME	Home return command
Command for parameter setting	
SPD	Speed setting
ACC	Acceleration/deceleration setting
OFS	Offset setting
Command for I/O port control	
OUT	Output to general-purpose port.
OUTP	Pulse output to general-purpose port.
OUTC	Counter value output to general-purpose port.
OUTS	Specified coordinate output to general-purpose port.
IOUT	Output to internal port.
CANS	Cancel of specified coordinate output to general-purpose port.
IN	Waiting for input.
INPC	Setting of input status of general-purpose port to counter.
INSP	Waiting for internal port input.
Command for timer/counter control	
CWIT	Waiting for counter.
TIM	Waiting for time.
TIMP	Preset of timer.
CNT	Preset of counter.
CNT+	Addition of counter value.
CNT-	Subtraction of counter value.
CNTC	Clear of all counters.
Command for program control	
NOP	Non-operation
RET	Return (declaration of ending a subroutine).
STOP	Stop
END	Program end
TAG	Jump to a tag (destination label)
PSEL	Program selection
Command for servo control	
SVON	Servo ON
SVOF	Servo OFF
Command for matrix operation	
MVM	Matrix movement
LOOP	MVM loop
MINI	Initialization of MVM counter.
Command for jump	
JMP	Unconditional jump.
JMPI	Jump with input condition.
JMPC	Jump with counter condition.
JMPT	Jump with timer condition.
BRAC	Jump to a tag of counter value.
Command for subroutine call	
CAL	Unconditional call (unconditional jump to specified subroutine).
CALI	Call with input condition (call of specified subroutine with input condition).
CALC	Call with counter condition.
CALT	Call with timer condition.
Command for task control	
TSTR	Task start
TSTO	Temporary stop of task.
TRSA	Task restart
TCAN	Compulsive finish of task.

## [External point designation mode]

Mode in which an axis is positioned by a signal output from the sequencer (PLC) or digital switch, without using a command of the controller. Coordinates of a specified point, speed and acceleration/deceleration should be registered beforehand in the table of the controller.

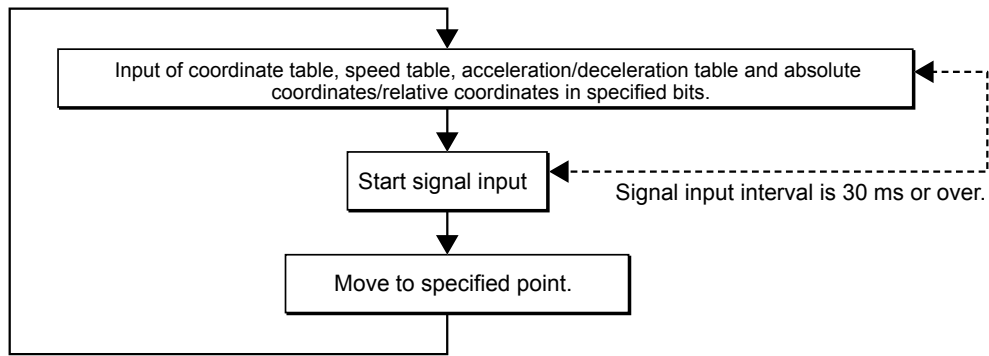

No. of tables that can be used:

Type of master unit: CA20-M10, CA20-M40

	Without extension I/O unit	With extension I/O unit
Coordinate table	16 points (4 bits) (Note 1)	999 points (10 bits)
Speed table	1 table (1 bit)	3 tables (2 bits)
Acceleration/deceleration table	1 table (1 bit)	2 tables (1 bit)
Coordinate system	Predetermined to absolute coordinate system (Bit designation is not permitted.)	Absolute coordinate system/relative coordinate system (1 bit)

Note 1: Eight (8) points (3 bits) when the pause input is made valid in a single axis control system.

Type of maser unit: CA10-M00B, CA10-M01B

Coordinate table	999 points (10 bits)
Speed table	10 tables (4 bits) (Note 2)
Acceleration/deceleration table	20 tables (5 bits)
Coordinate system	Absolute coordinate system/relative coordinate system (1 bit)

Note 2: The number of points and the number of bits that can be used varies with the assigned bit position.

## [Palletizing mode]

Mode in which operations of traveling and loading to pallets can be programmed easily only by specifying the number of workpieces, coordinates of locations, etc., without creating a program by combining instruction words.

A total of three patterns are provided.

M to 1  
Move from pallet to a specified point.

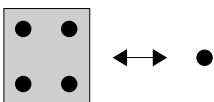

1 to M  
Move from a specified point to pallet.

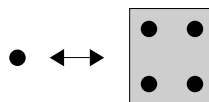

M to M  
Move from pallet to pallet.

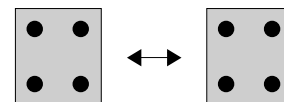

## [Pulse train input mode]

Mode in which an axis is moved by means of a pulse generator. This mode is available only for the CA20-M10 and CA20-M40.

Input pulse	[CW pulse + CCW pulse] (2-clock pulse system) or [Pulse + "+/-" sign] (1-clock system)	
Maximum input pulse frequency	500 kHz (line driver), 200 kHz (open collector)	
Input	Signal	Servo ON, reset, counter clear
	Specification	DC24 V, 10 mA
Output	Signal	Positioning finish, error, home position LS, Z-phase signals
	Specification	DC24 V, 20 mA (max.)
Applicable encoder	Line driver output (wire-saving type)	
Display	Error LED indication (on front of unit) and display on teach pendant.	
Protective function	Encoder error, overload, overvoltage, overflow, overcurrent	
Power supply, ambient conditions	Pursuant to the master unit specifications.	

\* See Page 234 for I/O connections.





# Details of Input and Output, and Example Connection

Master unit: CA20-M10, CA20-M40

[Details of system input and output] \* For the table of I/O pin numbers, see Page 199.

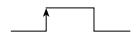
## [System input]

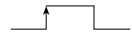
Pin No.	Signal name	Sequential mode Palletizing mode	External point designation mode	Remarks
28	Home return	ON: Start of home position return motion	Same as left.	ON 
29	Start	ON: Restart from currently stopped step or from temporary halt status.	ON: Start of axis feed as per currently specified table information.	Detection of rising edge. ON  ON 
30	Stop	ON: Stop after current step has been executed.	Invalid	When this input is ON, home return and start input are inoperative.
31	Reset	ON: Reset of error condition. (Effective while program execution is stopped.)	ON: Reset of error condition.	

Home return input is also possible from the general-purpose input port by mode setting of the controller.

## [System output]

Pin No.	Signal name	Sequential mode Palletizing mode	External point designation mode	Remarks
11	Running	ON during controller running and home return motion.	ON during robot operation.	
12	Error	ON at error generation.	Same as left.	
13	Positioning finish	ON when the robot has been positioned at a predetermined position. OFF while the robot is moving. (OFF while the robot is paused.)	Same as left.	
14	Home return finish	ON when home return is unnecessary at execution of move command. OFF when home return is necessary.	ON when home return is unnecessary at execution of move command. OFF when home return is necessary.	
15	Home position LS	Output of home position limit switch status of axis.	Same as left.	
16	Z-phase	Output of Z-phase signal which is output from axis motor encoder.	Same as left.	

(Applicable to master unit, slave unit and extension I/O unit.)

## [Input and output that can be assigned to general-purpose I/O port]

\* The setting function varies with the system setting operation of controller.

Signal name	* Setting function	Sequential mode Palletizing mode	External point designation mode
	Input/output		
Robot single operation	Input	The single operation mode is operative when this input is ON with the start input or start key set ON. In this mode, axis feed command and output command are inhibited.	Inoperative.
Restart	Input	Even if the power is turned off or reset while this input is ON, contents of counter, etc., are not cleared.	Inoperative.
Escape	Input	When this input is ON during execution of MVE command, an axis slows down and stops, and the system interprets that the relevant step has finished.	Inoperative.
Pause (feed hold)	Input	ON: Feed hold (slowdown and stop). To restart, set ON the start input. To cancel, set ON the reset input.	
Program selection 2 <sup>0</sup> Program selection 2 <sup>1</sup> Program selection 2 <sup>2</sup>	Input	Input signal for specifying a program number ( No.1 - No.8) at program selection.	Inoperative.
Home return	Input	ON: Start of home return motion. (Initial setting is assigned to Pin 28.)	
Palletizing	Input	ON: Palletizing mode OFF: Sequential mode (While the easy, external point designation or pulse train input mode is selected, this input is invalid.)	Inoperative.
Wait for input	Output	ON when the system is waiting for an input during program execution.	Inoperative.
Pausing	Output	ON when an axis has slowed down and stopped after recognizing pause input. (OFF when the pause mode is canceled.)	
Ready	Output	ON when the teach pendant and RS232C are inoperative and no error is generated.	

# Master unit: CA20-M10, CA20-M40

## [Example connection of input and output]

\* For the table of I/O pin numbers, see Page 199.

### [System input]

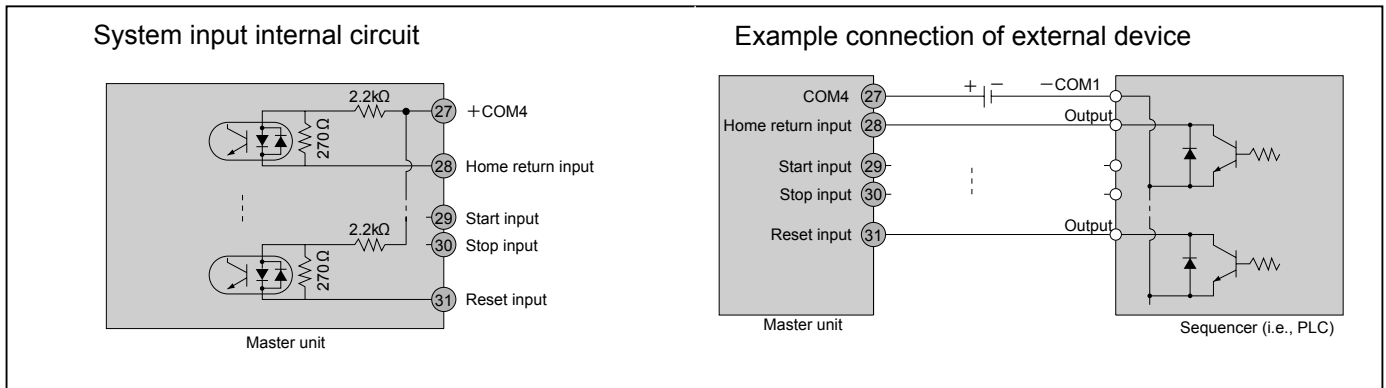

### [System output]

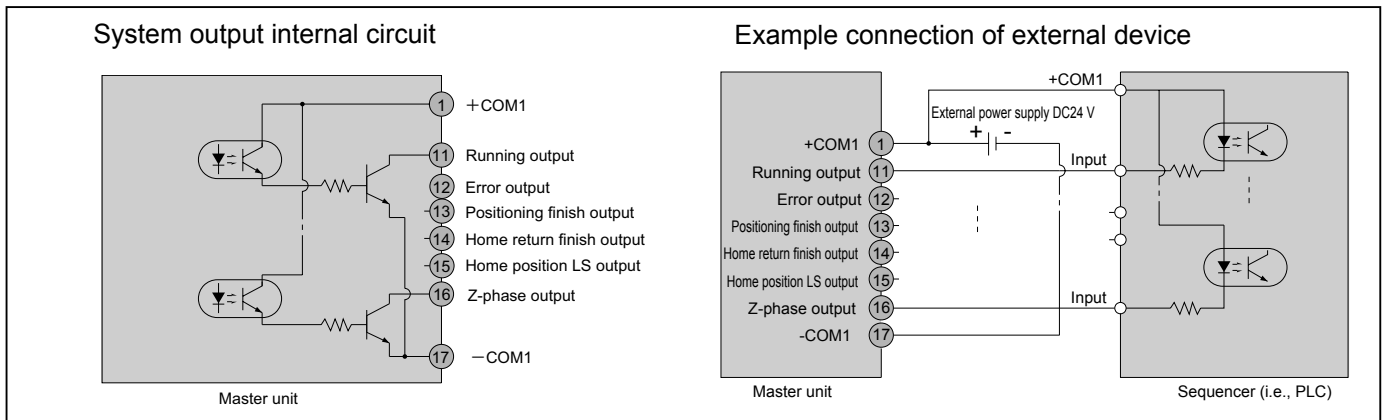

### [Emergency stop input]

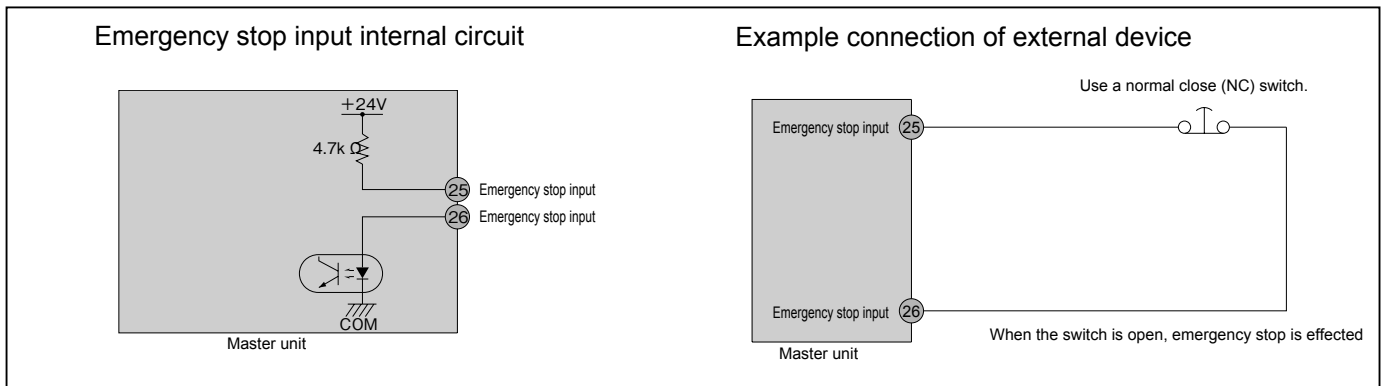

### [Emergency stop output]

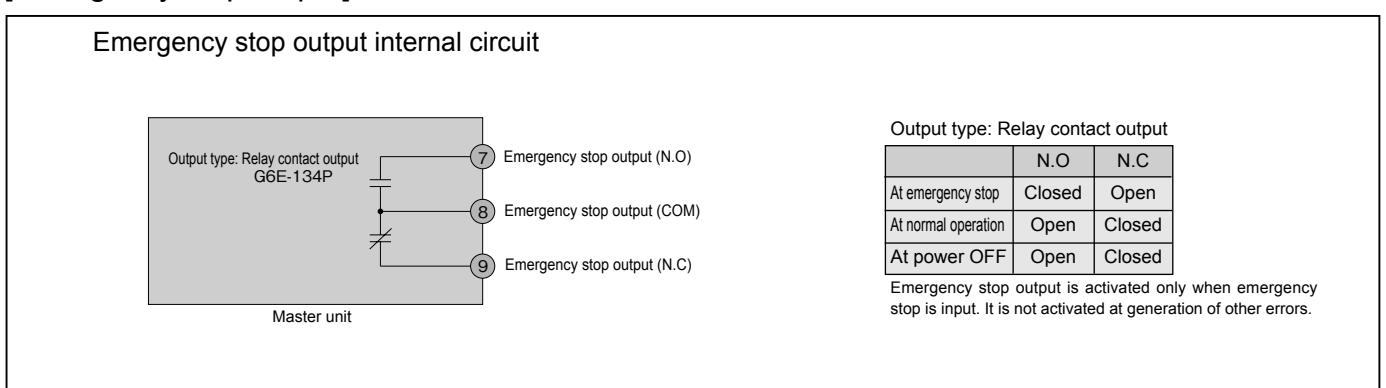

Master unit: CA20-M10, CA20-M40  
 [Example connection of input and output]

\* For the table of I/O pin numbers, see Page 199.

[General-purpose input]

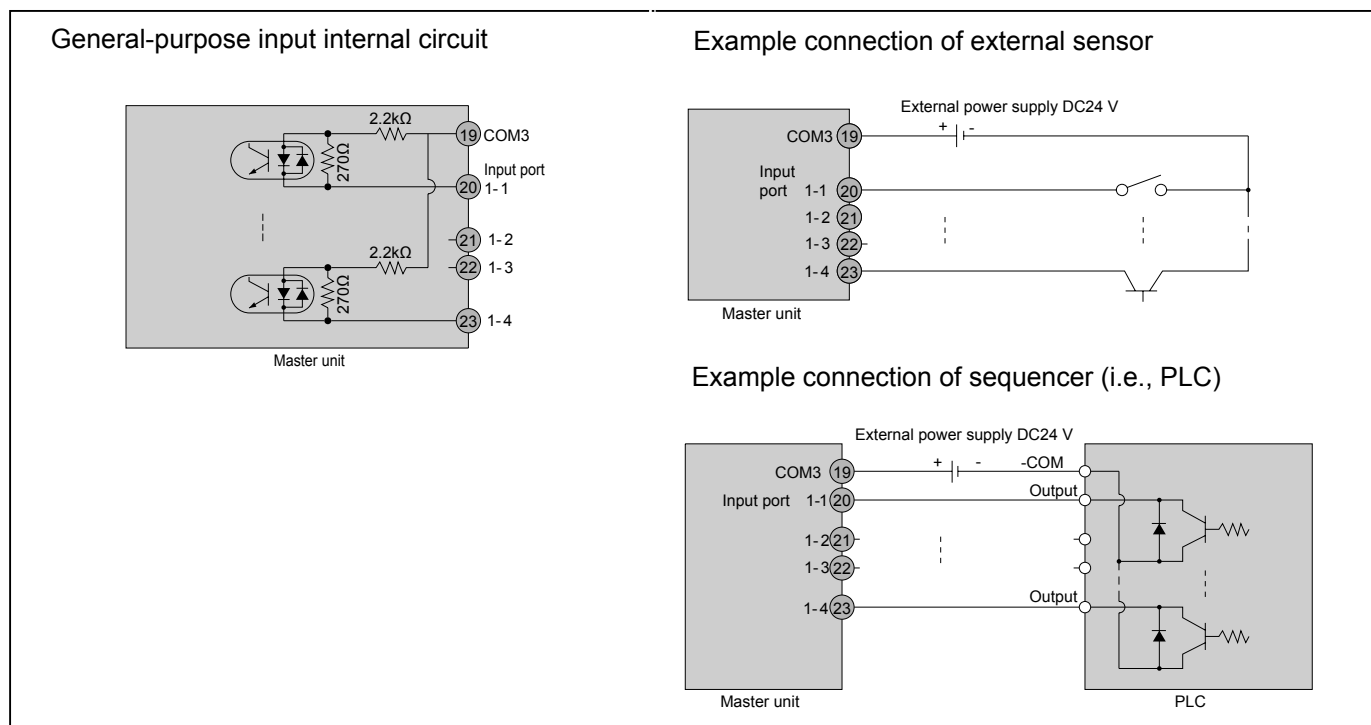

[General-purpose output]

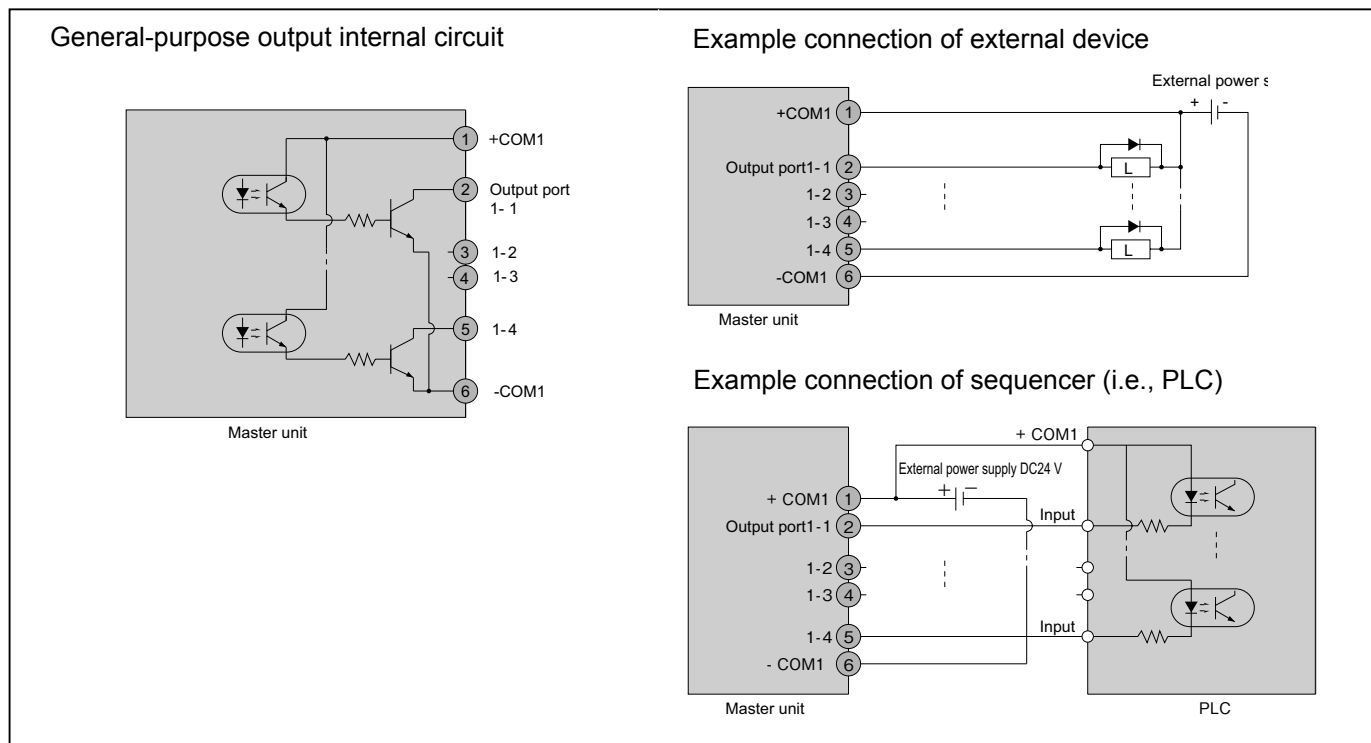

# Master unit: CA20-M10, CA20-M40

## [Input and output of pulse train input mode]

\* For the table of I/O pin numbers, see Page 199.

### [System input] (when master unit (CA20-M10, M40) is set to pulse train input mode)

Pin No.	Input/output	Signal name	Description
12	Output	Error	ON when an error has occurred in the controller.
13	Output	Positioning finish	ON when the difference between the total value of command pulses (i.e., pulses from external controller) and the total value of feedback pulses (i.e., axis motor encoder pulses) becomes smaller than the in-position length set in the parameter. (OFF when the servo is OFF.)
15	Output	Home position LS	Output of home position limit switch status of axis.
16	Output	Z-phase	Output of one Z-phase signal from axis motor encoder per motor revolution.
29	Input	Servo ON	Control of energized or de-energized state of axis servo motor. ON: Servo ON (servo lock) OFF: Servo OFF (servo free) This is the servo-free state controlled by software, different from the servo-free state controlled by hardware as in emergency stop.
30	Input	Counter clear	ON: Clears the software counter in the controller, which accumulates command pulses.
31	Input	Reset	ON: Resets errors generated in the controller.
33 34 35 36	Input	+CLK/±CLK -CLK/SIGN	Command pulses can be input from the teach pendant in either of the two methods; 2-clock method and 1-clock method.

### [Input]

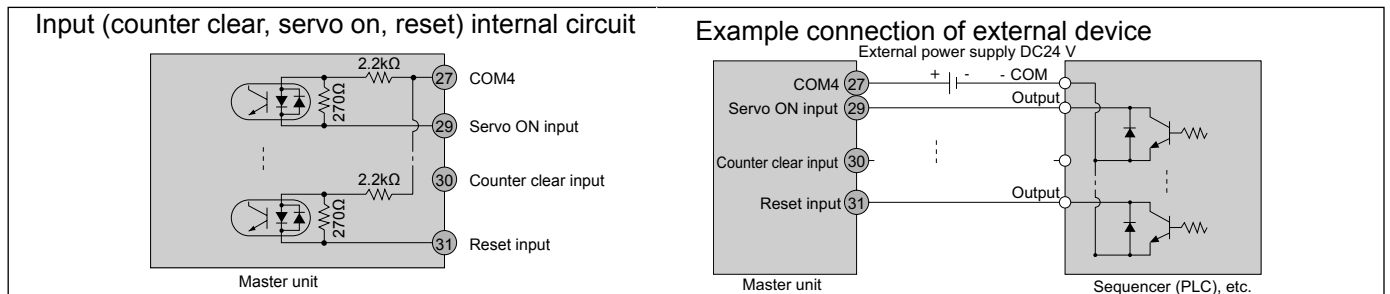

### [Output]

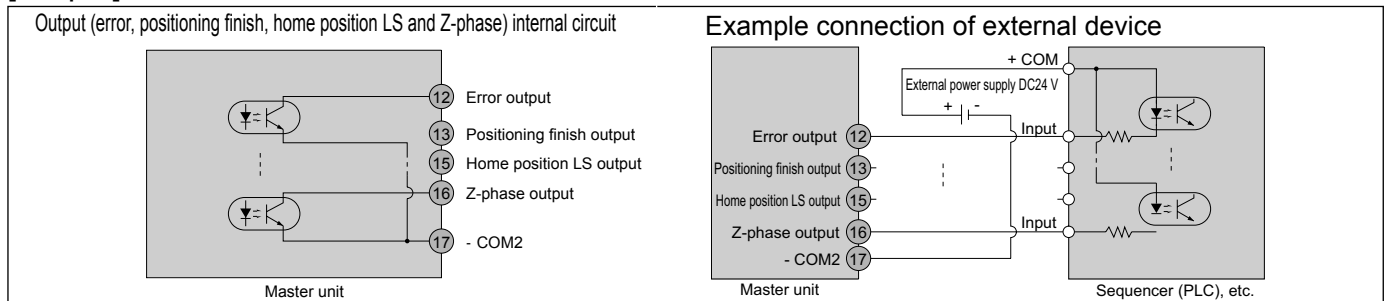

### [Pulse train input]

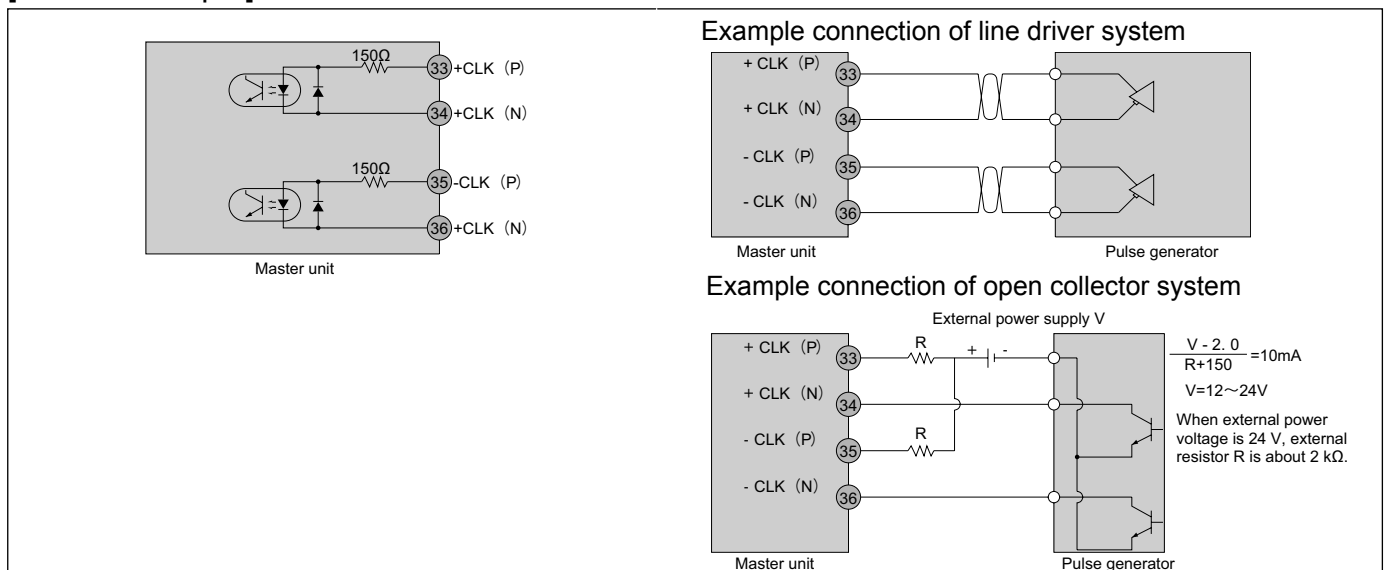



The pulse train input comes in the two systems; line driver system and open collector system. To improve reliability such as noise resistance, however, use of the line driver system is recommended.

## High-performance master unit: CA10-M00B

[Details of system input and output]\* For the table of I/O pin numbers, see Page 202.

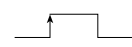
### [System input]

Pin No.	* Setting function	Sequential mode Palletizing mode	External point designation mode	Remarks
	Signal name			
21	Home return	ON: Start of home position return motion	Same as left.	ON 
22	Start	ON: Restart from currently stopped step or from hold feed status.	ON: Start of axis feed as per currently specified table information.	Detection of rising edge. ON  ON 
23	Stop	ON: Stop after current step has been executed.	Invalid	When this input is ON, home return and start input are inoperative.
24	Reset	ON: Reset of error condition. (Effective while program execution is stopped.)	ON: Reset of error condition.	

### [System output]

Pin No.	* Setting function	Sequential mode Palletizing mode	External point designation mode	Remarks
	Signal name			
17	Running	ON during controller running and home return motion.	ON during robot operation.	
18	Error	ON at error generation.	Same as left.	
19	Positioning finish	ON when the robot has been positioned at a predetermined position. OFF while the robot is moving. (OFF while the robot is paused.)	Same as left.	
20	Home return finish	ON when home return is unnecessary at execution of move command. OFF when home return is necessary.	ON when home return is unnecessary at execution of move command. OFF when home return is necessary.	

### [Input and output that can be assigned to general-purpose I/O port]

(Applicable to high-performance master unit, slave unit and extension I/O unit.)

\* The setting function varies with the system setting operation of controller.

Signal name	* Setting function	Sequential mode Palletizing mode	External point designation mode
	Input/output		
Robot single operation	Input	The single operation mode is operative when this input is ON with the start input or start key set ON. In this mode, axis feed command and output command are inhibited.	Inoperative.
Restart	Input	Even if the power is turned off or reset while this input is ON, contents of counter, etc., are not cleared.	Inoperative.
Escape	Input	When this input is ON during execution of MVE command, an axis slows down and stops, and the system interprets that the relevant step has finished.	Inoperative.
Pause (feed hold)	Input	ON: Feed hold (slowdown and stop). To restart, set ON the start input. To cancel, set ON the reset input.	
Program selection 2 <sup>0</sup> Program selection 2 <sup>1</sup> Program selection 2 <sup>2</sup> Program selection 2 <sup>3</sup>	Input	Input signal for specifying a program number (No.1 - No.16) at program selection.	Inoperative.
Palletizing	Input	ON: Palletizing mode OFF: Sequential mode (While the easy, external point designation or pulse train input mode is selected, this input is invalid.)	Inoperative.
Wait for input	Output	ON when the system is waiting for an input during program execution.	Inoperative.
Pausing	Output	ON when an axis has slowed down and stopped after recognizing pause input. (OFF when the pause mode is canceled.)	
Ready	Output	ON when the teach pendant and RS232C are inoperative and no error is generated.	

# High-performance master unit: CA10-M00B

## [Example connection of input and output]

\* For the table of I/O pin numbers, see Page 202.

### [System and general-purpose input/output]

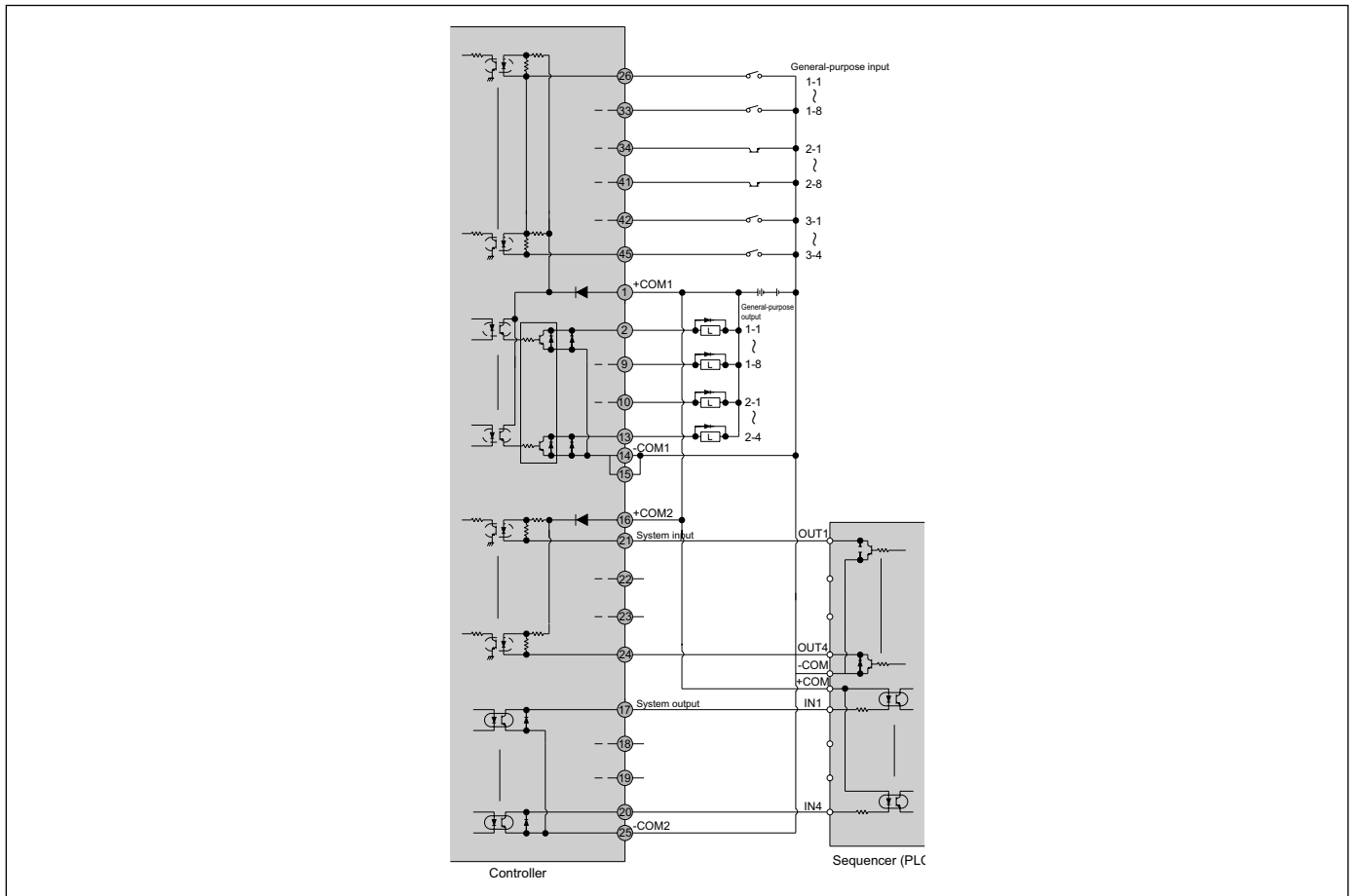

### [Emergency stop input]

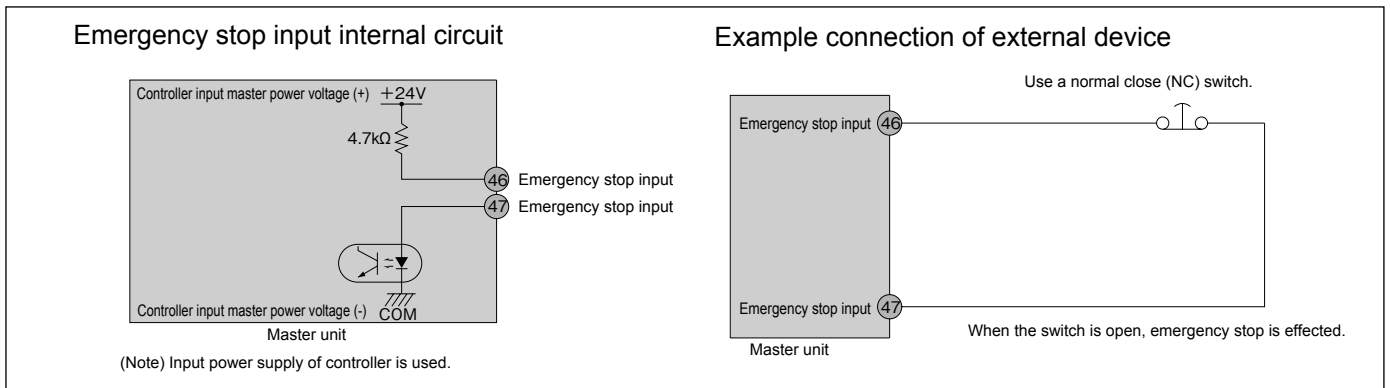

### [Emergency stop output]

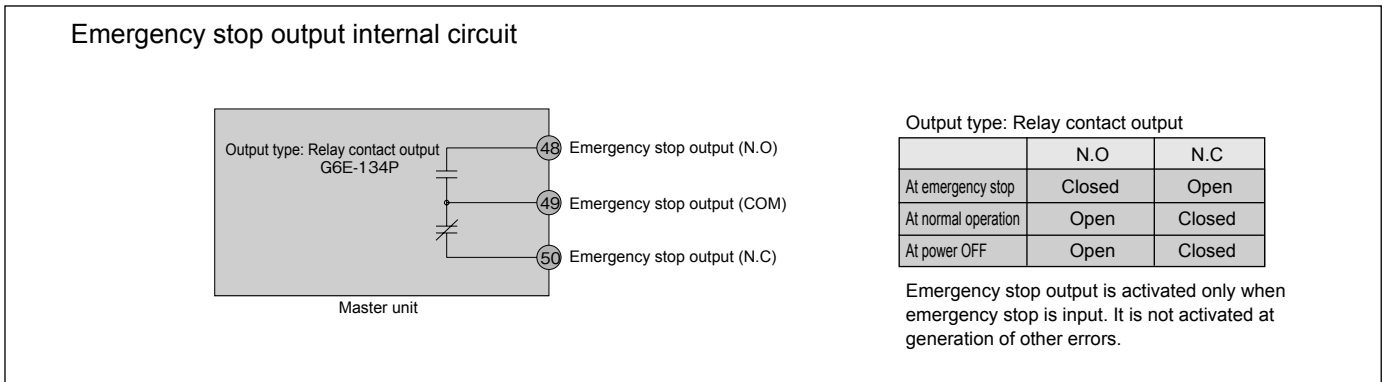

# High-performance master unit: (designed for CC-Link) CA10-M01B-CC

## [Details of input and output]

\* For the table of I/O pin numbers, see Page 205.

### [System input]

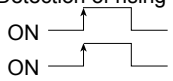
Remote output	Signal name	Sequential mode Palletizing mode	External point designation mode	Remarks
RYn0	Home return	ON: Start of home position return motion	Home return	Detection of rising edge. 
RYn1	Start	ON: Restart from currently stopped step or from hold feed status.	ON: Start of axis feed as per currently specified table information.	
RYn2	Stop	ON: Stop after current step has been executed.	Invalid	When this input is ON, home return and start input are inoperative.
RYn3	Reset	ON: Reset of error condition. (Effective while program execution is stopped.)	ON: Reset of error condition.	
RY(n+4)B — RY(n+4)F	Jog input	Jogging of a selected axis by specifying one of the three modes (inching, low-speed move, high-speed move) and move direction.		

### [System output]

Remote input	Signal name	Sequential mode Palletizing mode	External point designation mode	Remarks
RXn0	Running	ON during controller running and home return motion.	ON during robot operation.	
RXn1	Error	ON at error generation.	Same as left.	
RXn2	Positioning finish	ON when the robot has been positioned at a predetermined position. OFF while the robot is moving. (OFF while the robot is paused.)	Same as left.	
RXn3	Home return finish	ON when home return is unnecessary at execution of move command. OFF when home return is necessary.	ON when home return is unnecessary at execution of move command. OFF when home return is necessary.	
RX(n+4)B — RX(n+4)F	Jog output	Indication of jog acceptance or rejection, status during axis motion, etc.		

### [Input and output that can be assigned to general-purpose I/O port]

(Applicable to high-performance master unit, slave unit and extension I/O unit.)

\* The setting function changes with the system setting operation of controller.

Signal name	* Setting function	Sequential mode Palletizing mode	External point designation mode
	Input/output		
Robot single operation	Input	The single operation mode is operative when this input is ON with the start input or start key set ON. In this mode, axis feed command and output command are inhibited.	Inoperative.
Restart	Input	Even if the power is turned off or reset while this input is ON, contents of counter, etc., are not cleared.	Inoperative.
Escape	Input	When this input is ON during execution of MVE command, an axis slows down and stops, and the system interprets that the relevant step has finished.	Inoperative.
Pause (feed hold)	Input	ON: Feed hold (slowdown and stop). To restart, set ON the start input. To cancel, set ON the reset input.	
Program selection 2 <sup>0</sup> Program selection 2 <sup>1</sup> Program selection 2 <sup>2</sup> Program selection 2 <sup>3</sup>	Input	Input signal for specifying a program number (No.1 — No.16) at program selection.	Inoperative.
Palletizing	Input	ON: Palletizing mode OFF: Sequential mode (While the easy, external point designation or pulse train input mode is selected, this input is invalid.)	Inoperative.
Wait for input	Output	ON when the system is waiting for an input during program execution.	Inoperative.
Pausing	Output	ON when an axis has slowed down and stopped after recognizing pause input. (OFF when the pause mode is canceled.)	
Ready	Output	ON when the teach pendant and RS232C are inoperative and no error is generated.	

# High-performance master unit: (designed for CC-Link) CA10-M01B-CC

[Connection method of CC-Link cables and example connection of emergency stop input and output]

\* For the table of I/O pin numbers, see Page 205.

## [Connection method of CC-Link exclusive cables]

- [1] Be sure to connect terminating resistors with units on both ends of the CC-Link system.  
Connect each terminating resistor between DA and DB.
- [2] In the CC-Link system, terminating resistors to be connected differ with cables to be used.

Type of cable	Terminating resistor
CC-Link exclusive cable	110 Ω, 1/2 W (brown, brown, brown)
CC-Link exclusive cable designed for Ver1.10	
High-performance CC-Link exclusive cable	130 Ω, 1/2 W (brown, orange, brown)

No terminating resistors are attached to this controller.

- [3] The connection method is shown below.

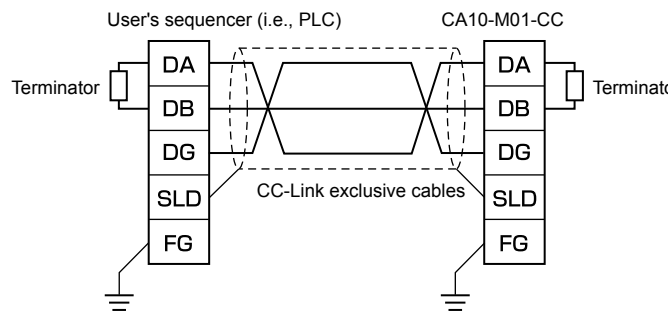

## [Emergency stop input]

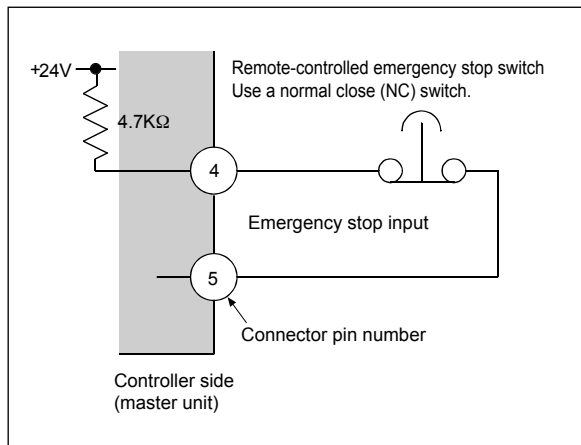

## [Emergency stop output]

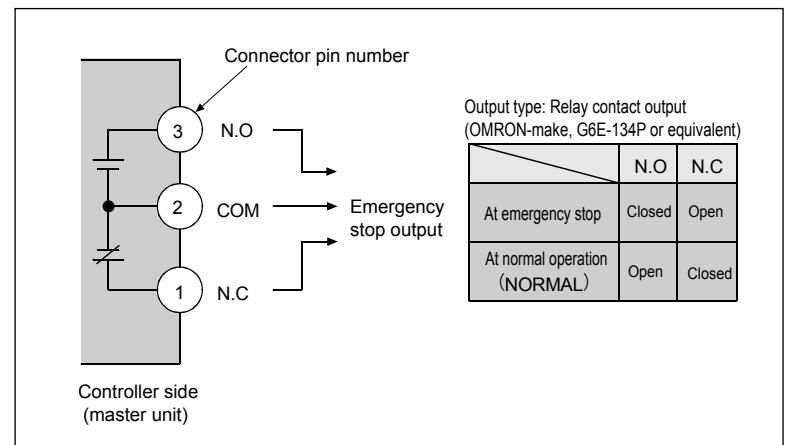

## CC-Link connector (accessory)

Used to connect a CC-Link exclusive cable for data linkage.

Perform wiring to this connector, which should be inserted then to the CA10-M01B controller.

Connector pin array	Pin No.	Signal name	Cable color
	1	Communication cable (DA)	Blue
	2	Communication cable (DB)	White
	3	Digital GND (DG)	Yellow
	4	Shield (SLD)	Shield
	5	Frame ground (FG)	

Connector made by Phoenix Contact  
Type: MSTB2.5/S-ST-5.08AU

SLD and FG are connected in the unit.

## Emergency stop connector (accessory)

Used for input and output of emergency stop signal.

Perform wiring to this connector, which should be inserted then to the CA10-M01B controller.

Connector pin array	Pin No.	Signal name	Cable color	Description
	1	EMONC	Output	Emergency stop output (N.C)
	2	EMOCOM	Output	Emergency stop output (COM)
	3	EMONO	Output	Emergency stop output (N.O)
	4	EMIN	Input	Emergency stop input
	5	EMIN	Input	Emergency stop input

Connector made by Wago Japan  
Type: 734-105



# Slave unit: CA20-S10, CA20-S40

## [Example connection of input and output]

\* For the table of I/O pin numbers, see Page 208.

### [General-purpose input]

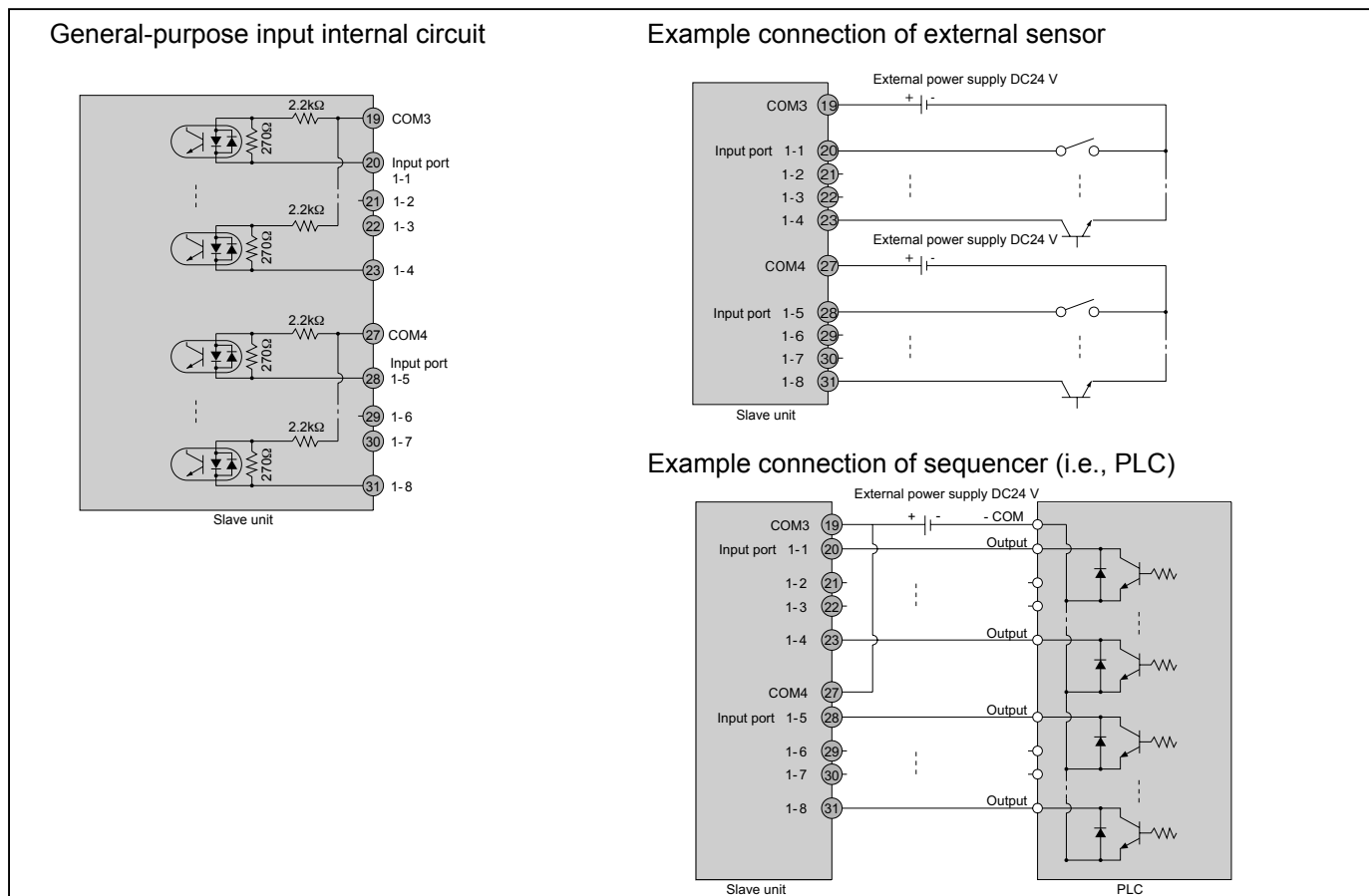

### [General-purpose output]

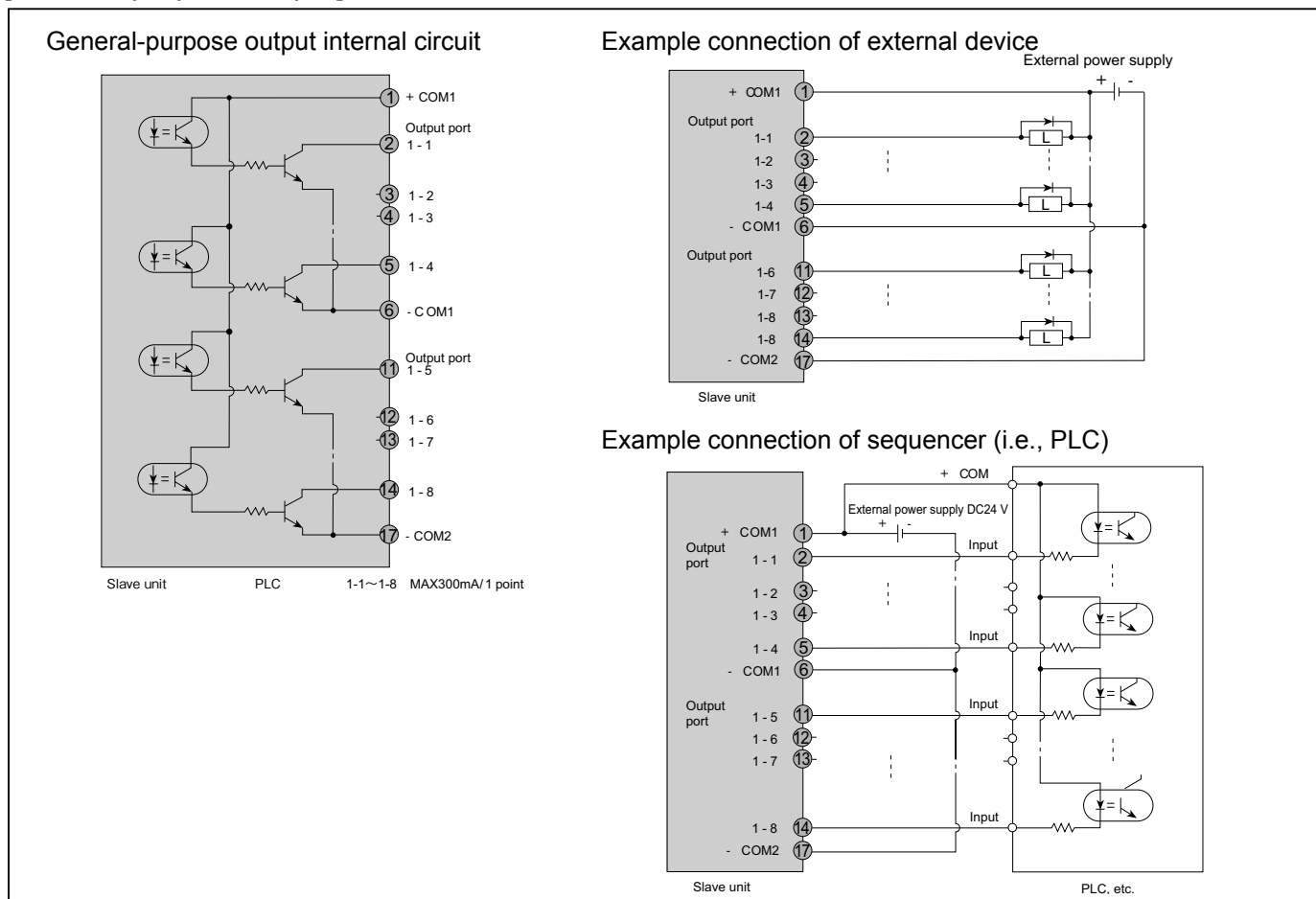

# Extension I/O unit: CA20-EX-A20

## [Example connection of input and output]

\* For the table of I/O pin numbers, see Page 212.

### [General-purpose input]

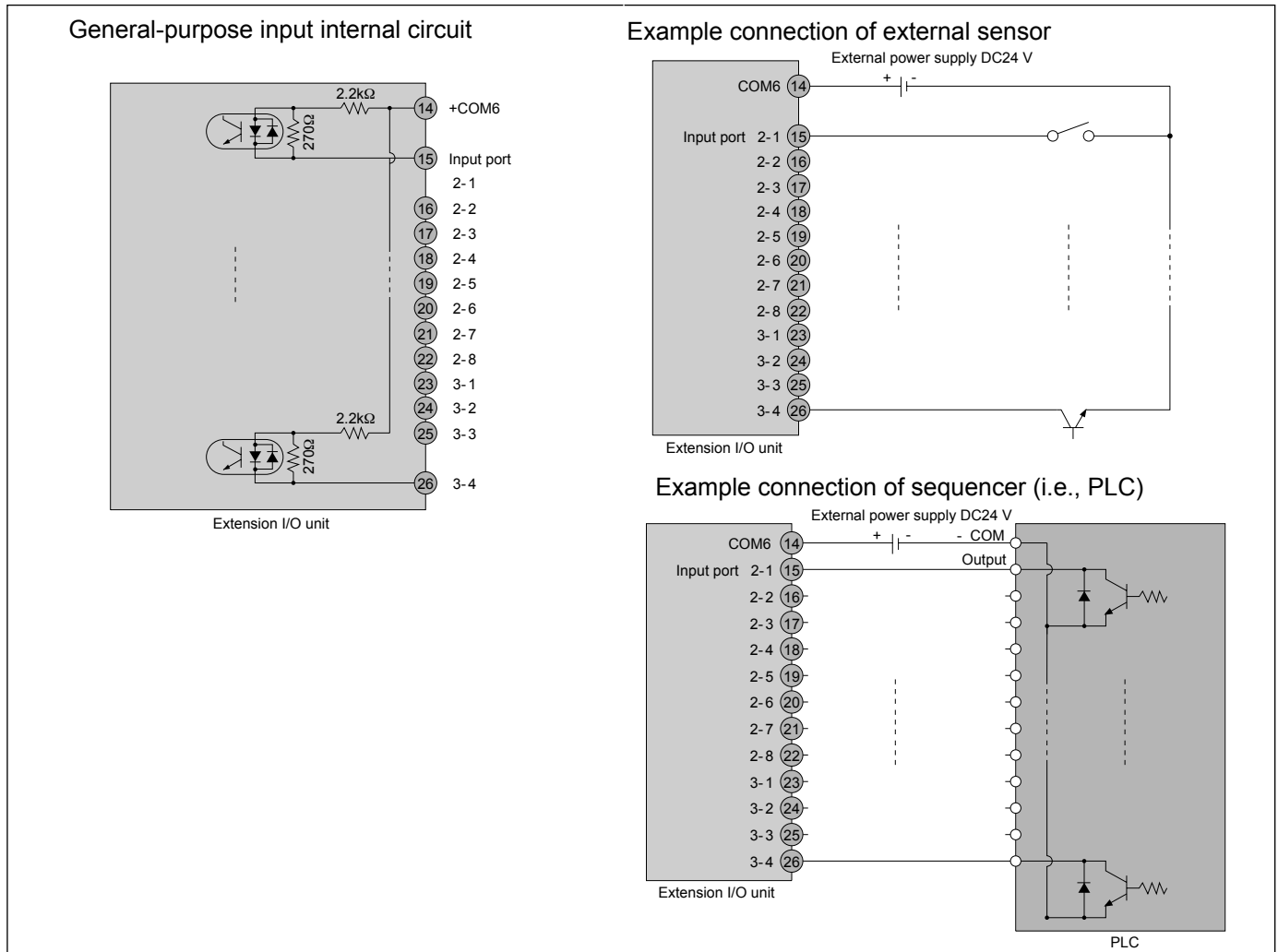

### [General-purpose output]

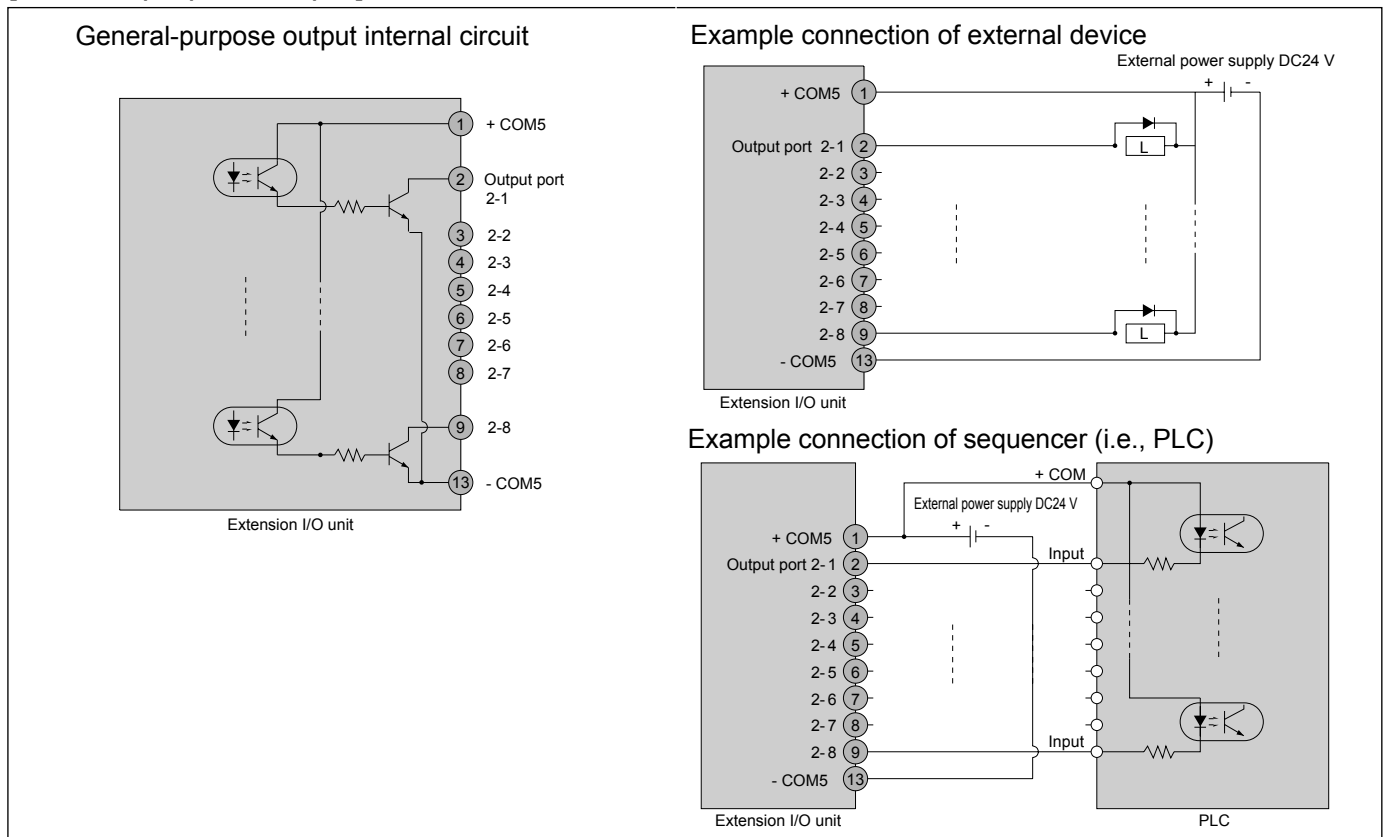

# Extension I/O unit: CA10-EX-B40

## [Example connection of input and output]

\* For the table of I/O pin numbers, see Page 213.

### [General-purpose input and output]

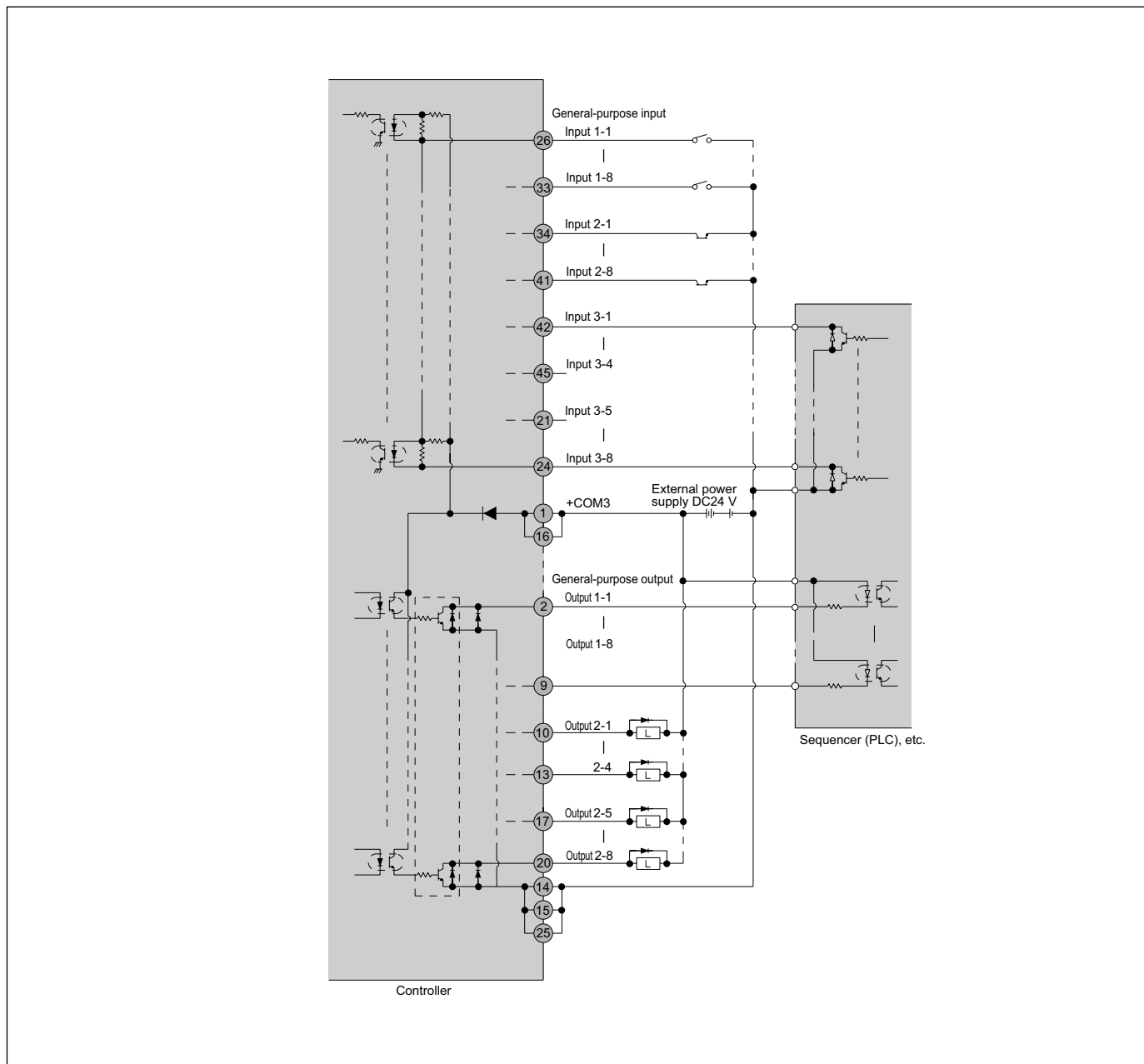

# How to Calculate Tact (Cycle) Time

The tact time (cycle time) of a single robot can be figured out from the following calculations. It provides only a yardstick, however, because the time thus calculated differs more or less from actual time.

The calculation comes in the two methods; Example calculation 1 (when equi-speed interval is included) and Example calculation 2 (when an axis starts decelerating during acceleration). Either calculation method is selectable according to the relationship between travel distance, specified speed and specified acceleration/deceleration time.

[1] When "travel distance > specified speed (V) × specified acceleration/deceleration time (ACC)" ⇒ Example calculation 1

[2] When "travel distance ≤ specified speed (V) × specified acceleration/deceleration time (ACC)" ⇒ Example calculation 2

- For the acceleration/deceleration time, refer to the relationship between acceleration/deceleration and load as shown in the next page.
- For the acceleration/deceleration time and maximum speed under maximum payload, refer to the specifications of each axis type.

## Example calculation 1

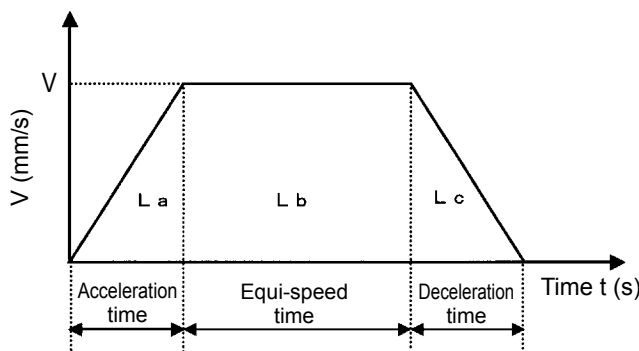

La = Travel distance at acceleration (mm)  
 Lb = Travel distance at equi-speed  
 Lc = Travel distance at deceleration (mm)  
 Lt = Equi-speed time (s)  
 L = Travel distance (mm) = La + Lb + Lc  
 V = Specified speed (mm/s)  
 t = Time (s)  
 Acc = Specified acceleration/deceleration time (s)

<Operating conditions>

Specified speed : V = 1,000 mm/s

Specified acceleration/deceleration time : ACC = 0.3 s

Travel distance: L = 400 mm

$$L_a = \frac{1}{2} \times V \times \text{Acc} = \frac{1}{2} \times 1000 \times 0.3 = 150 \text{ mm}$$

$$L_c = \frac{1}{2} \times V \times \text{Acc} = \frac{1}{2} \times 1000 \times 0.3 = 150 \text{ mm}$$

$$L_t = \frac{L - (L_a + L_c)}{V} = \frac{400 - (150 + 150)}{1000} = 0.1 \text{ s}$$

$$\begin{aligned} \text{Tact time} &= \text{Acceleration time} + \text{Equi-speed time} + \text{Deceleration time} \\ &= 0.3 + 0.1 + 0.3 \\ &= \underline{0.7 \text{ sec}} \end{aligned}$$

## Example calculation 2

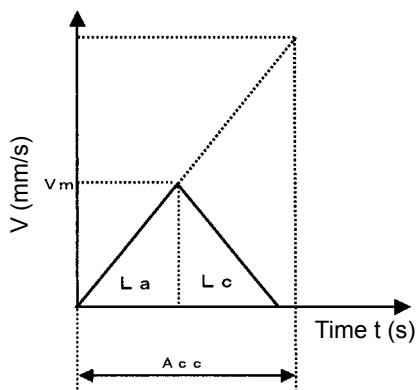

V = Specified speed (mm/s)  
 Vm = Real maximum speed (mm/s)  
 L = Travel distance (mm)  
 La = Travel distance at acceleration (mm)  
 Lc = Travel distance at deceleration (mm)  
 Acc = Specified acceleration/deceleration time (s)  
 t = Time (s)

$$L_a = \frac{L}{2} = \frac{200}{2} = 100 \text{ mm}$$

$$L_c = \frac{L}{2} = \frac{200}{2} = 100 \text{ mm}$$

$$\begin{aligned} \text{Tact time} &= 2 \sqrt{\frac{L \times \text{ACC}}{V}} = 2 \sqrt{\frac{200 \times 0.3}{1000}} \\ &= \underline{0.49 \text{ sec}} \end{aligned}$$

<Operating conditions>

Specified speed : V = 1,000 mm/s

Specified acceleration/deceleration time : ACC = 0.3 s

Travel distance: L = 200 mm

Relationship between acceleration/deceleration and load:

Horizontal installation

Payload (kg)

Drive system	Type	Set speed (mm/s)	Lead (mm)	Acceleration/deceleration time (Note 1)					
				0.1sec	0.2sec	0.3sec	0.4sec	0.5sec	0.6sec
Ball screw type	BB05D	800	12	4	5	6	6	6	6
		400	6	8	10	15	15	15	15
	BB07D	800	12	4	5	12	12	12	12
		400	6	10	15	30	30	30	30
	BB10E	1000	20	7	11	15	15	15	15
		500	10	20	25	30	30	30	30
		250	5	25	35	50	50	50	50
	BB30E	1000	20	12	18	20	20	20	20
		"500,250"	"10,5"	25	35	50	50	50	50
	BB30F	1000	20	25	35	40	40	40	40
		"500,250"	"10,5"	50	65	80	80	80	80
	BB50F	1000	20	25	40	60	60	60	60
"500,250"		"10,5"	50	75	100	100	100	100	
BB50G	1000	20	40	70	100	100	100	100	
	"500,250"	"10,5"	60	100	150	150	150	150	
Timing belt type	BB10E	1000	21	5	10	15	15	15	15
	BB10F	1000	21	10	15	20	20	20	20
		2000	42	2	4	6	8	10	10
	BB30E	1000	21	5	10	15	15	15	15
	BB30F	1000	21	10	20	40	40	40	40
		2000	42	6	10	12	14	20	20
	BB50F	1000	21	10	20	40	40	40	40
BB50G	2000	42	7	10	12	14	20	20	

Vertical installation

Payload (kg)

Drive system	Type	Set speed (mm/s)	Lead (mm)	Acceleration/deceleration time (Note 1)					
				0.1sec	0.2sec	0.3sec	0.4sec	0.5sec	0.6sec
Ball screw type	BB05D	800	12	1	2	3	3	3	3
		400	6	2	3	4	4	4	4
	BB07D	800	12	1	2	4	4	4	4
		400	6	3	5	8	8	8	8
	BB10E	1000	20	3	4	5	5	5	5
		500	10	6	9	12	12	12	12
		250	5	17	20	22	22	22	22
	BB30E	1000	20	3	4	5	5	5	5
		500	10	6	9	12	12	12	12
		250	5	17	20	22	22	22	22
	BB30F	1000	20	6	7	10	10	10	10
		500	10	14	16	20	20	20	20
		250	5	30	35	40	40	40	40
	BB50F	1000	20	8	10	12	12	12	12
		500	10	15	20	25	25	25	25
		250	5	30	40	50	50	50	50
	BB50G	1000	20	20	22	25	25	25	25
		500	10	30	40	50	50	50	50
250		5	40	50	60	60	60	60	

Note 1: The acceleration/deceleration time is the time until an axis reaches the set speed as given in the table.

\* For the pause time after travel, 1.0 s or over is necessary.

\* Vibration may be caused under some installation conditions.

\* The payload given above is exerted just above the slider.



# BA-II Series] Component List per Unit

2-axis, 3-axis or 4-axis control system (For details, see the pages for each unit and fill in this sheet.)

Guide No	Unit name	Code designation			Q'ty	Guide No	Unit name	Code designation			Q'ty
		BB	BB	BB				CA	CA	CA	
1	Actuator (axis 1)	BB	-	-	-	6	Tube tray, flexible tray	BA10-TT-	-	-	
	Actuator (axis 2)	BB	-	-	-	7	Cable grip	BA10-CG-M2	-	-	
	Actuator (axis 3)	BB	-	-	-	8	Strain relief	BA10-SC-A02	-	-	
	Actuator (axis 4: R-axis)	BB00D	-	-	-	9	Controller (master)	CA	0-M	-	
2	Axis combination bracket	BA	-	BK	-	10	Link cable	CA20-S	-	-	
		BA	-	BK	-			CA10-LC-A	-	-	
3	Controller cable	BB10-CC-M	-	-	-	11	Extension I/O unit	CA20-EX-A20	-	-	
		BB10-CC-M	-	-	-			CA10-EX-B40	-	-	
		BB10-CC-M	-	-	-			CA10-IC-A	-	-	
		BB10-CC-M	-	-	-			CA10-IC-B	-	-	
		BA10-BX-	-	-	-			ICBL-	-	00	
4	CN box	BA10-BX-	-	-	-	13	Regeneration discharge unit	ABSU-	-	000	
		BA10-BX-	-	-	-			CA10 - MC - B20	-	-	
		BA10-	-	-	-			TPH-	-	-	
5	Flexible tube, Flexible duct	BA10-	-	-	-	15	Teach pendant	TPH-	-	-	
		BA10-	-	-	-						
		BA10-	-	-	-						

Notes on filling this sheet:

\* Fill in necessary numbers and alphabets in the boxes  together with required quantities.

\* Packing charge, transportation fee and excise tax shall be quoted separately.

\* This component list may not be adequate, depending on user's requirements.